

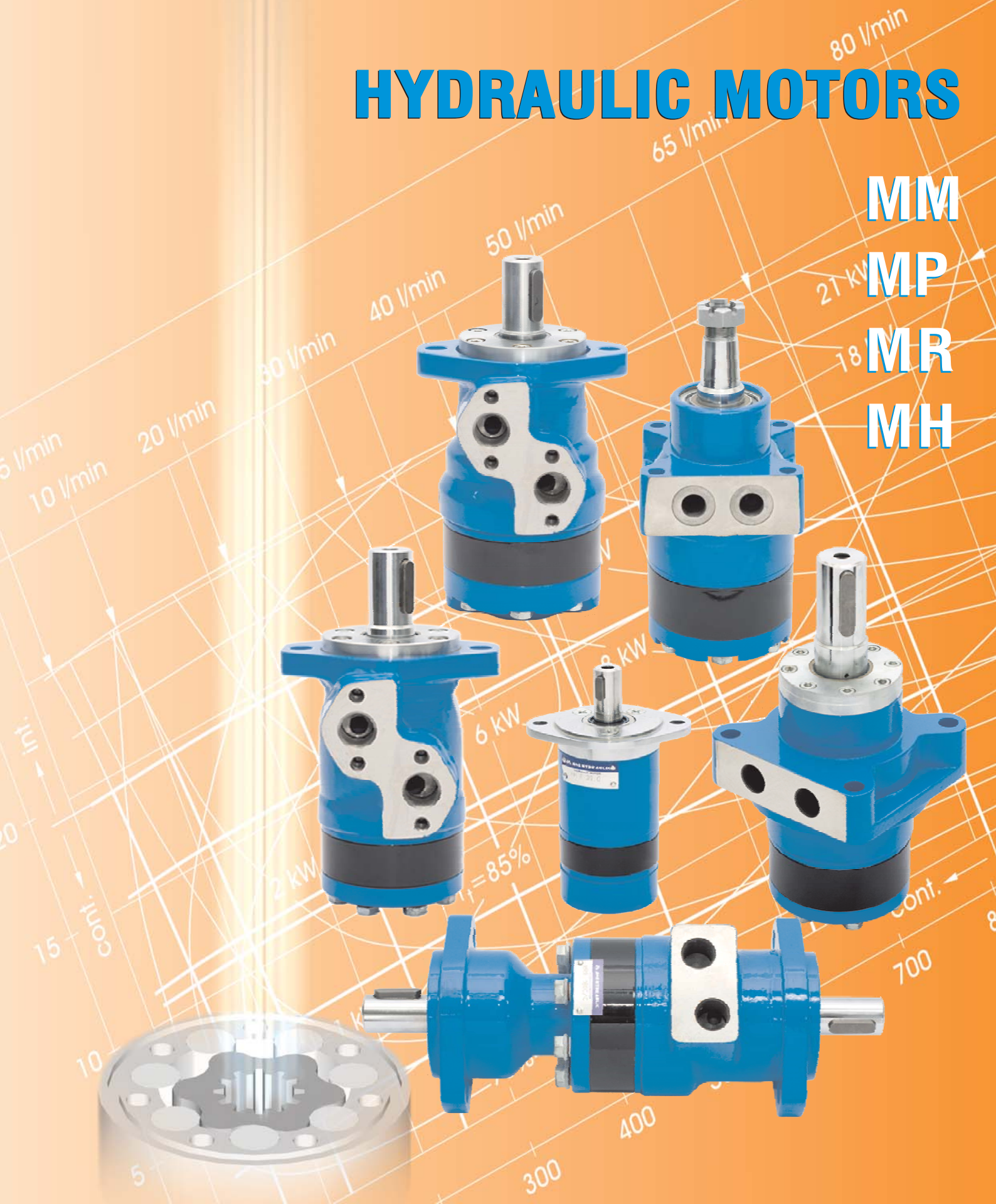

M+S HYDRAULIC

HYDRAULIC MOTORS

MM
MP
MR
MH



SPOOL VALVE HYDRAULIC MOTORS

CONTENTS

	Page
<input type="checkbox"/> Hydraulic Motors Series MM	4
<input type="checkbox"/> Hydraulic Motors Series MP	13
<input type="checkbox"/> Hydraulic Motors Series MR	32
<input type="checkbox"/> Hydraulic Motors Series MR...T (tacho)	43
<input type="checkbox"/> Hydraulic Motors Series SP	44
<input type="checkbox"/> Hydraulic Motors Series SR	50
<input type="checkbox"/> Hydraulic Motors Series MRNA	59
<input type="checkbox"/> Hydraulic Motors Series MRFL	61
<input type="checkbox"/> Hydraulic Motors with Dual Shaft Series MRB	63
<input type="checkbox"/> Hydraulic Motors Series PL	66
<input type="checkbox"/> Hydraulic Motors Series RL	71
<input type="checkbox"/> Hydraulic Motors Series PK	76
<input type="checkbox"/> Hydraulic Motors Series RK	80
<input type="checkbox"/> Hydraulic Motors Series RW	84
<input type="checkbox"/> Hydraulic Motors Series MH	93
<input type="checkbox"/> Hydraulic Motors Series HW	101
<input type="checkbox"/> Motor Additional Options	125
<input type="checkbox"/> Motors with Speed Sensor	126
<input type="checkbox"/> Application Calculations	128

"M+S HYDRAULIC" can accept no responsibility for possible errors in catalogues, brochures and other printed material.
"M+S HYDRAULIC" reserves the right to alter its products without notice. This also applies to products already on order provided that such alterations can be made without subsequential changes being necessary in specifications already agreed.

SPOOL VALVE HYDRAULIC MOTORS

GENERAL INFORMATION:

Orbit motors convert hydraulic energy (pressure, oil flow) into mechanical energy (torque, speed). Hydraulic orbit motors operate on the principle of an internal gear (rotor) rotating within a fixed external gear (stator). The internal gear transmits the torque generated by the application of pressure from hydraulic oil fed into motor which is then delivered via the motor's output shaft. Orbit motors have high starting torque and constant output torque at wide speed range.

DISTRIBUTOR VALVE

MM, MP, MR, SP, SR, MH, PL, RL, PK, RK, RW, HW series motors have spool valve: the distributor valve has been integrated with the output shaft. The cardan shaft rotates distributor valve and transfers mechanical energy from gerotor set to output shaft. The valve has hydrodynamic bearings and has infinite life when load ratings are not exceeded.

GEARWHEEL SET

There are two forms of gearwheel set:

- Gerotor set has plain teeth. These type of motors are suitable for long operating periods at moderate pressures or short operating periods at high pressures. MM, MP, SP, PL and PK series motors have gerotor set.

- Roll-gerotor set has teeth fitted with rollers. The rollers reduce local stress and the tangential reaction forces on the rotor reducing friction to a minimum. This gives long operating life and better efficiency even at continuous high pressures. Roll-gerotor sets are recommended for operation with thin oil and for applications with continually reversing loads. MR, SR, RL, RK, MH, RW and HW series motors have roll-gerotor set.

FEATURES:

Standard Motor

The standard motor mounting flange is located as close to the output shaft as possible. This type of mounting supports the motor close to the shaft load. This mounting flange is also compatible with many standard gear boxes.

Wheel Motor

W mounting flange makes the motors possible to fit a wheel hub or a winch drum so that the radial load acts closer to motor bearings. This gives the best utilization of the bearing capacity and is a very compact solution.

Needle Bearing

MPN and MRN have an output shaft supported in needle bearing. These types motors are suitable for operating conditions such us frequent start and stops, vibration on the shaft, high static and dynamic radial loads in short operating terms.

Low Leakage

LL Series hydraulic motors are designed to operate at the whole standard range of working conditions (pressure drop and frequency of rotation), but with considerable decreased volumetric losses in the drain ports. This motors are suitable for hydraulic systems with series-connected motors with demands for low leakage.

Low Speed Valve

LSV feature optimizes the motor for low-speed performance. Motors with this valving provide very low speed while maintaining high torque. They are designed to run continuously at low speed (up to 200 min⁻¹) at normal pressure drop and reduced flow. Optimal run is guaranteed at frequency of rotation from 20 to 50 min⁻¹. Motors with this valving have an increased starting pressure and are not recommended for using at pressure drop less than 40 bar.

Free Running

FR motors are with increased clearance at all friction parts, allowing the shaft to rotate more freely with less mechanical drag. The increased clearance also improves lubrication of the wear surfaces of gear set and friction parts. Additional advantages of "FR" version are prolonging of the life of the hydraulic motors at high speeds, as well as the possibility to use them in systems with wide variation of the loading. FR Series motors are designed to operate with high speed /over than 300 min⁻¹/ and low pressure drop. Volumetric efficiency may be reduced slightly.

High Pressure Shaft Seal

The high pressure shaft seals allow the motors to withstand high case pressures at high speeds without external drain line.

Motors with Speed Sensor

Motors are available with integrated inductive speed sensor. The output signal is a standardized voltage signal that can be used to control the speed of a motor. The torque and the radial load of the motor are not affected by the installation of speed sensor.

HYDRAULIC MOTORS MM



CONTENTS

Specification data	5
Function diagrams	6÷8
Dimensions and mounting ...	9÷10
Shaft extensions	11
Permissible shaft loads	11
Order code	12

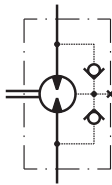

APPLICATION

- » Conveyors
- » Textile machines
- » Mining machinery
- » Machine tools
- » Ventilators
- » Construction plant equipment and access platforms etc.

OPTIONS

- » Model - Spool valve, gerotor
- » With or without flange
- » Side and rear ports
- » Series with pressure valve(s)
- » Shafts - straight and splined
- » Metric and BSPP ports
- » Speed sensing;
- » Other special features

Pressure Settings at Flow
Q=2 lpm [.53 GPM], 32 mm²/s [150 SUS], 50°C [122°F]

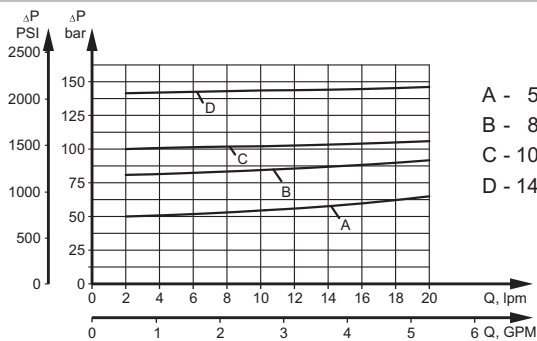

A - 50 bar [725 PSI]
 B - 80 bar [1160 PSI]
 C - 100 bar [1450 PSI]
 D - 140 bar [2030 PSI]

MMP Series with Integrated Internal Crossover Relief Valve
A → B, Δp=100 or 50 bar [1450 or 725 PSI]

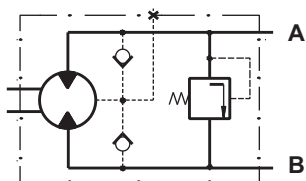

MMP Series with Integrated Internal Crossover Relief Valve
B → A, Δp=100 or 50 bar [1450 or 725 PSI]

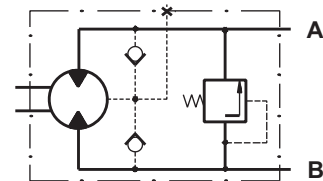

Pressure Losses

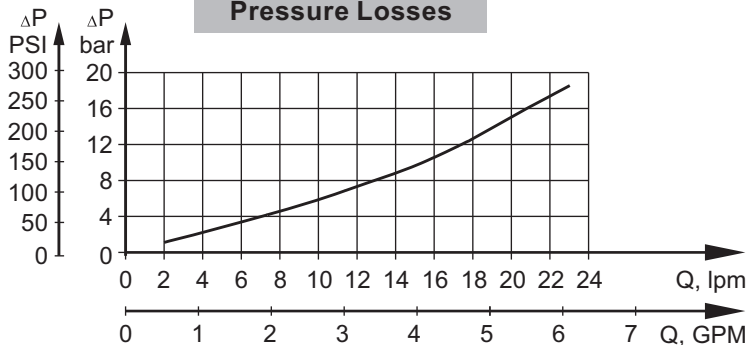

MMD Series with Integrated Internal Crossover Relief Valves
A ↔ B, Δp=100 or 50 bar [1450 or 725 PSI]

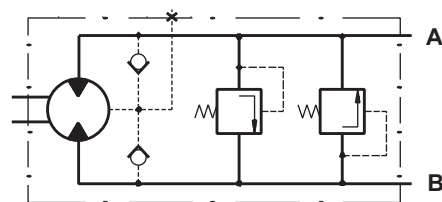

GENERAL

Max. Displacement,	cm ³ /rev [in ³ /rev]	50 [3.05]
Max. Speed,	[RPM]	2440
Max. Torque,	daNm [lb-in]	cont.: 4,5 [398] int.: 5,8 [513]
Max. Output,	kW [HP]	3,2 [4.3]
Max. Pressure Drop,	bar [PSI]	cont.: 105 [1500] int.: 140 [2030]
Max. Oil Flow,	lpm [GPM]	25 [6.6]
Min. Speed,	[RPM]	20
Pressure fluid		Mineral based- HLP(DIN 51524) or HM(ISO 6743/4)
Temperature range,	°C [°F]	-40÷140 [-40÷284]
Optimal Viscosity range,	mm ² /s [SUS]	20÷75 [98÷347]
Filtration		ISO code: 18/16/13 According to ISO 4406-1999

SPECIFICATION DATA

Type	MM 8	MM 12.5	MM 20	MM 32	MM 40	MM 50	
Displacement, cm³/rev [in³/rev]	8,2 [50]	12,5 [77]	19,9 [1.22]	31,6 [1.93]	39,8 [2.43]	50 [3.08]	
Max. Speed, [RPM]	Cont.	1950	1550	1000	630	500	400
	Int.*	2450	1940	1250	800	630	500
Max. Torque, daNm [lb-in]	Cont.	1,1 [95]	1,6 [140]	2,5 [220]	4,0 [350]	4,5 [400]	4,6 [410]
	Int.*	1,5 [135]	2,3 [200]	3,5 [310]	5,7 [500]	7,0 [620]	8,8 [780]
	Peak**	2,1 [187]	3,3 [293]	5,1 [453]	6,4 [568]	8,2 [725]	10,0 [885]
Max. Output, kW [HP]	Cont.	1,8 [2.4]	2,4 [3.2]	2,4 [3.2]	2,4 [3.2]	2,2 [3.0]	1,8 [2.4]
	Int.*	2,6 [3.5]	3,2 [4.3]	3,2 [4.3]	3,2 [4.3]	3,2 [4.3]	3,2 [4.3]
Max. Pressure Drop, bar [PSI]	Cont.	100 [1450]	100 [1450]	100 [1450]	100 [1450]	90 [1310]	70 [1020]
	Int.*	140 [2030]	140 [2030]	140 [2030]	140 [2030]	140 [2030]	140 [2030]
	Peak**	200 [2900]	200 [2900]	200 [2900]	160 [2320]	160 [2320]	160 [2320]
Max. Oil Flow, lpm [GPM]	Cont.	16 [4.2]	20 [5.3]	20 [5.3]	20 [5.3]	20 [5.3]	20 [5.3]
	Int.*	20 [5.3]	25 [6.6]	25 [6.6]	25 [6.6]	25 [6.6]	25 [6.6]
Max. Inlet Pressure, bar [PSI]	Cont.	140 [2030]	140 [2030]	140 [2030]	140 [2030]	140 [2030]	140 [2030]
	Int.*	175 [2540]	175 [2540]	175 [2540]	175 [2540]	175 [2540]	175 [2540]
	Peak**	225 [3260]	225 [3260]	225 [3260]	225 [3260]	225 [3260]	225 [3260]
Max. Return Pressure without Drain Line or Max. Pressure in Drain Line, bar [PSI]	Cont. 0-100 RPM	140 [2030]	140 [2030]	140 [2030]	140 [2030]	140 [2030]	140 [2030]
	Cont. 100-400 RPM	105 [1500]	105 [1500]	105 [1500]	105 [1500]	105 [1500]	105 [1500]
	Cont. 400-800 RPM	50 [725]	50 [725]	50 [725]	50 [725]	50 [725]	50 [725]
	Cont. >800 RPM	20 [290]	20 [290]	20 [290]	-	-	-
	Int.* 0-max. RPM	140 [2030]	140 [2030]	140 [2030]	140 [2030]	140 [2030]	140 [2030]
Max. Return Pressure with Drain Line, bar [PSI]	Cont.	140 [2030]	140 [2030]	140 [2030]	140 [2030]	140 [2030]	140 [2030]
	Int.*	175 [2540]	175 [2540]	175 [2540]	175 [2540]	175 [2540]	175 [2540]
	Peak**	225 [3260]	225 [3260]	225 [3260]	225 [3260]	225 [3260]	225 [3260]
Max. Starting Pressure with Unloaded Shaft, bar [PSI]	4 [60]	4 [60]	4 [60]	4 [60]	4 [60]	4 [60]	
Min. Starting Torque, daNm [lb-in]	At max. press. drop Cont.	0,7 [60]	1,2 [105]	2,1 [185]	3,4 [300]	3,8 [335]	4,1 [365]
	At max. press. drop Int.*	1,0 [90]	1,7 [150]	2,9 [255]	4,8 [425]	6,2 [550]	7,9 [700]
Min. Speed***, [RPM]	50	40	30	30	25	20	
Weight, kg [lb] For "F" flange: +0,200 [441]	MM	1,9 [4.2]	2,0 [4.41]	2,1 [4.63]	2,2 [4.85]	2,3 [5.07]	2,5 [5.51]
	MMF(S)	2,0 [4.41]	2,1 [4.63]	2,2 [4.85]	2,3 [5.07]	2,4 [5.29]	2,6 [5.73]
	MMP	2,2 [4.85]	2,3 [5.07]	2,4 [5.29]	2,5 [5.51]	2,6 [5.73]	2,8 [6.17]
	MMD	2,6 [5.73]	2,7 [5.95]	2,8 [6.17]	2,9 [6.39]	3,0 [6.61]	3,2 [7.05]

* Intermittent operation: the permissible values may occur for max. 10% of every minute.

** Peak load: the permissible values may occur for max. 1% of every minute.

*** For speeds lower than given, consult factory or your regional manager.

- Intermittent speed and intermittent pressure must not occur simultaneously.
- Recommended filtration is per ISO cleanliness code 20/16. A nominal filtration of 25 micron or better.
- Recommend using a premium quality, anti-wear type mineral based hydraulic oil HLP(DIN51524) or HM (ISO 6743/4).
If using synthetic fluids consult the factory for alternative seal materials.
- Recommended minimum oil viscosity 13 mm²/s [70 SUS] at 50°C [122°F].
- Recommended maximum system operating temperature is 82°C [180°F].
- To assure optimum motor life fill with fluid prior to loading and run at moderate load and speed for 10-15 minutes.

FUNCTION DIAGRAMS

MM 8

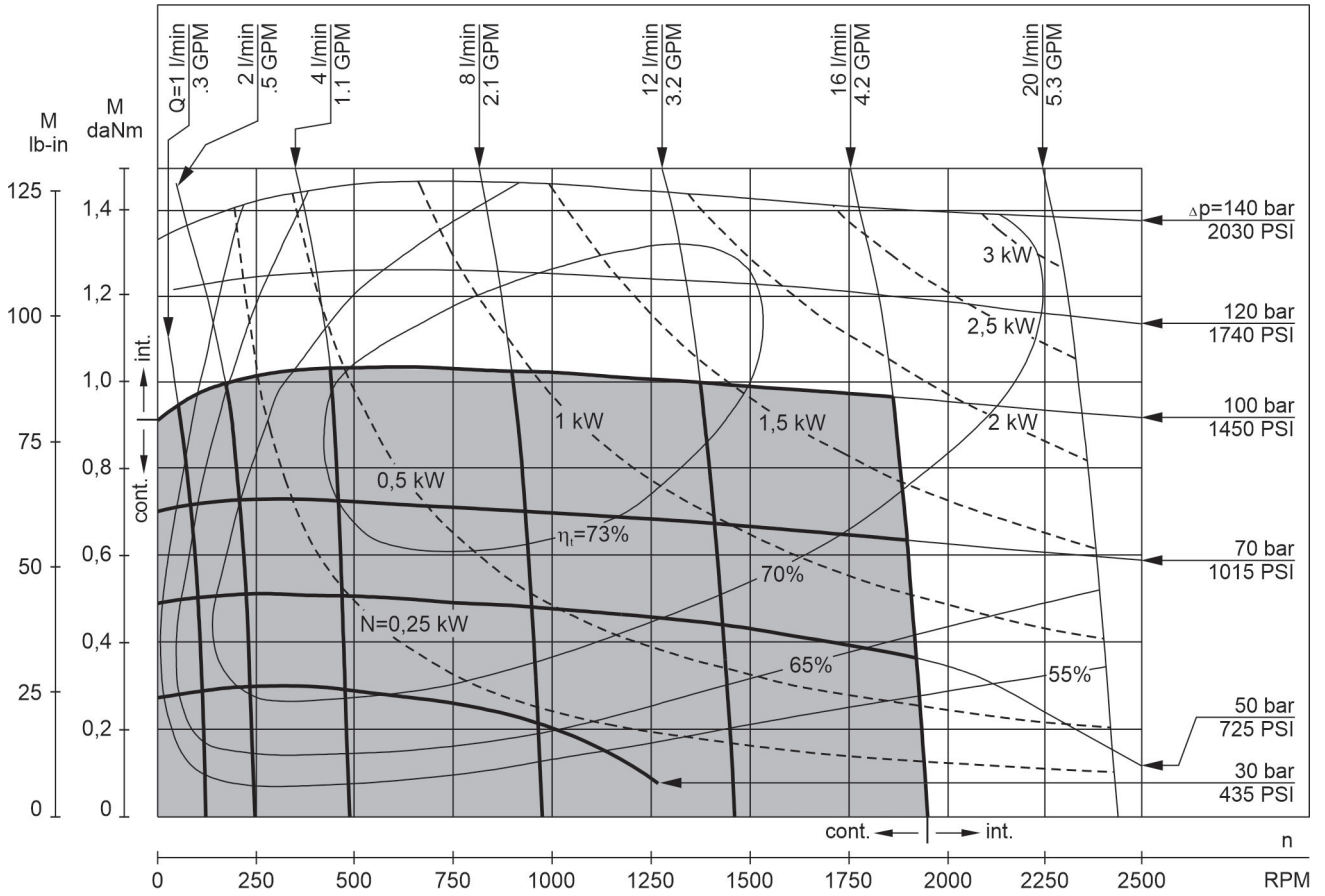

MM 12,5

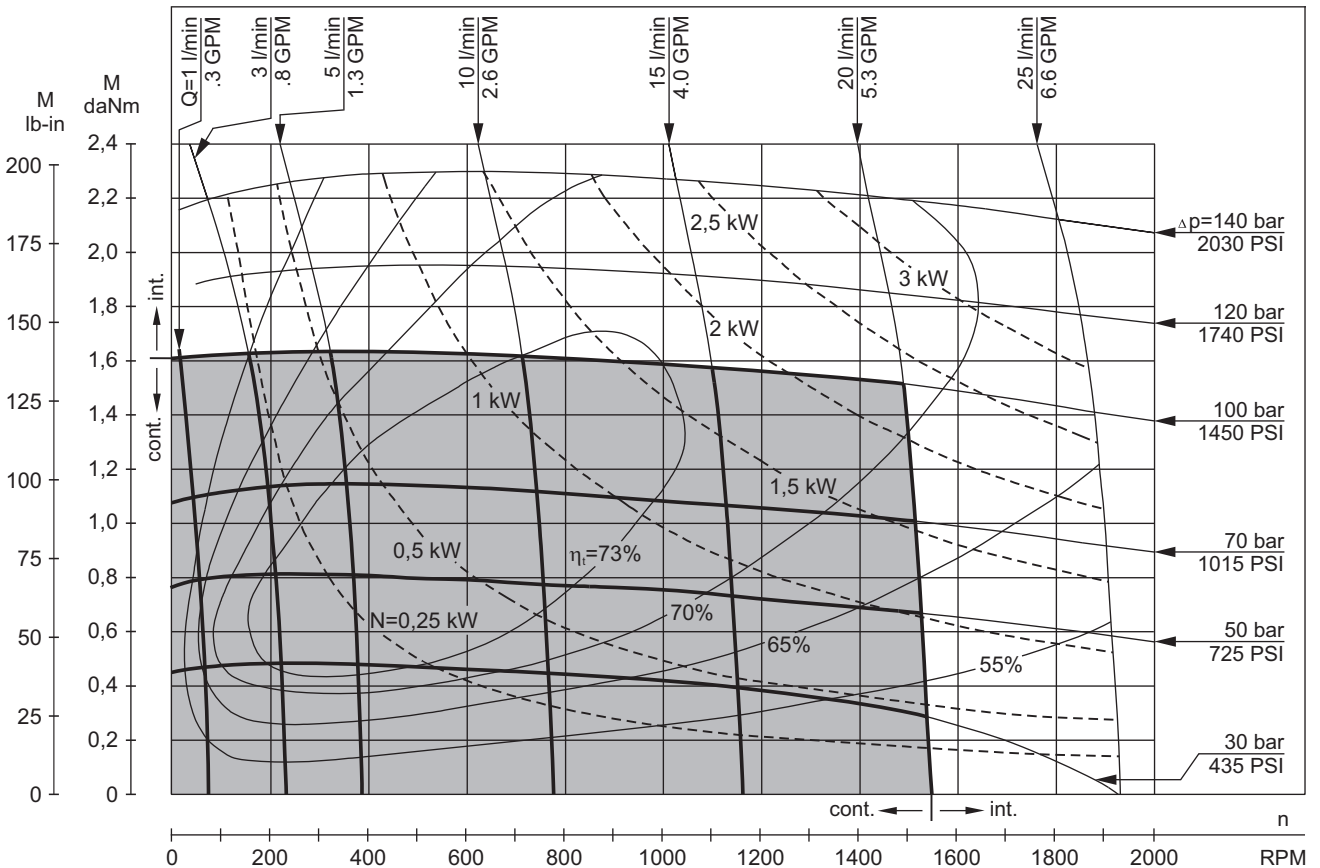

The function diagrams data is for average performance of randomly selected motors at back pressure $5 \div 10$ bar [72.5 PSI-145 PSI] and oil with viscosity of $32 \text{ mm}^2/\text{s}$ [150 SUS] at 50°C [122°F].

FUNCTION DIAGRAMS

MM 20

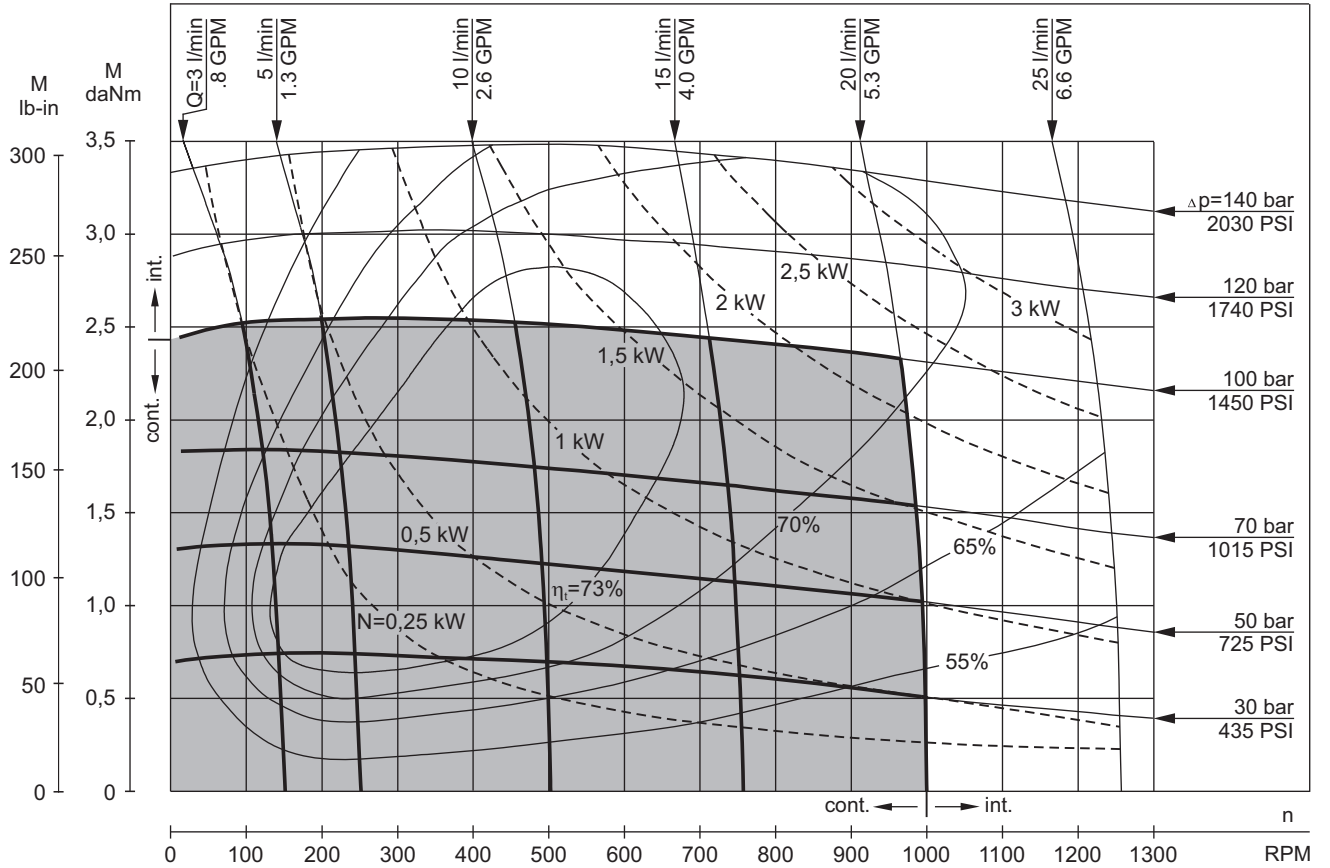

MM 32

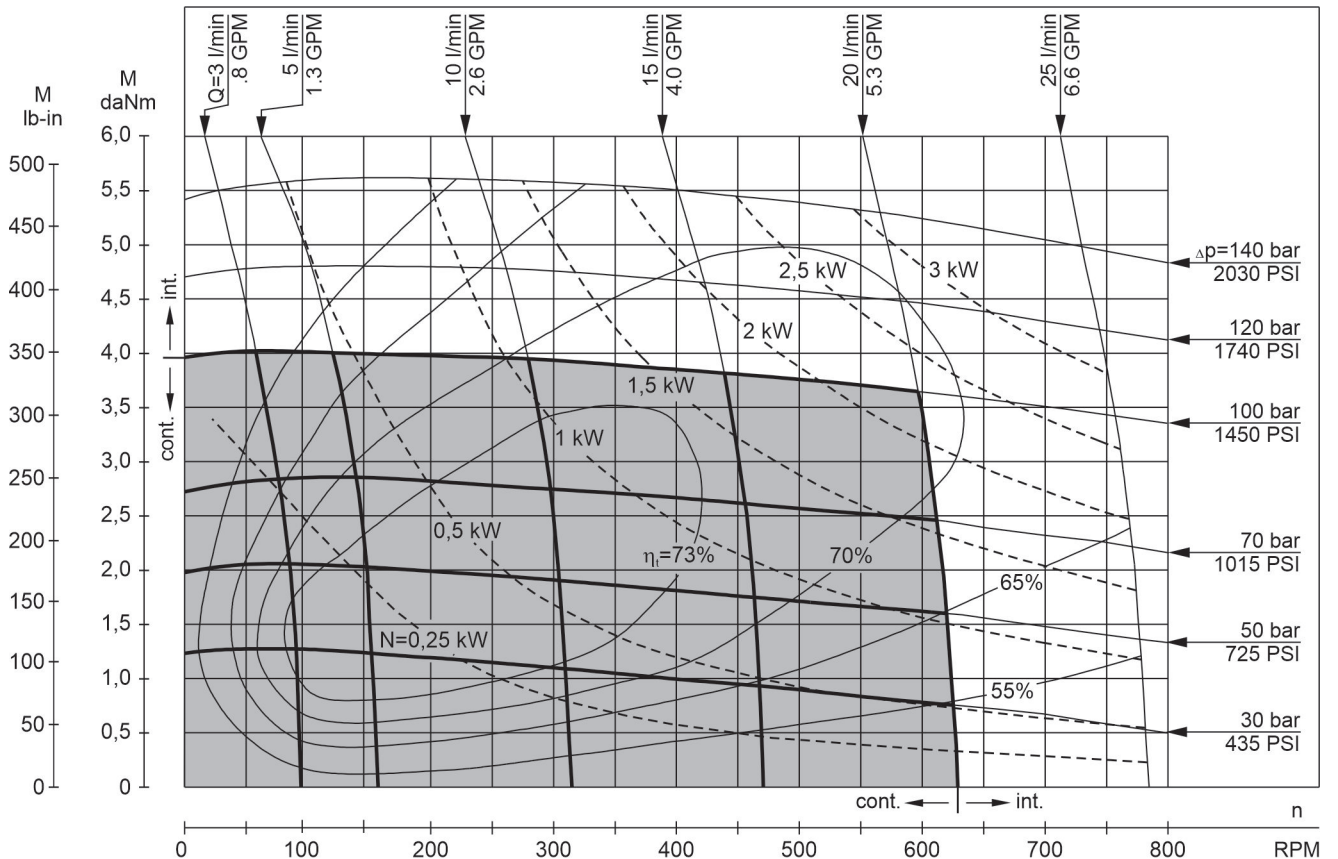

The function diagrams data is for average performance of randomly selected motors at back pressure 5 ± 10 bar [72.5 PSI-145 PSI] and oil with viscosity of 32 mm²/s [150 SUS] at 50°C [122°F].

FUNCTION DIAGRAMS

MM 40

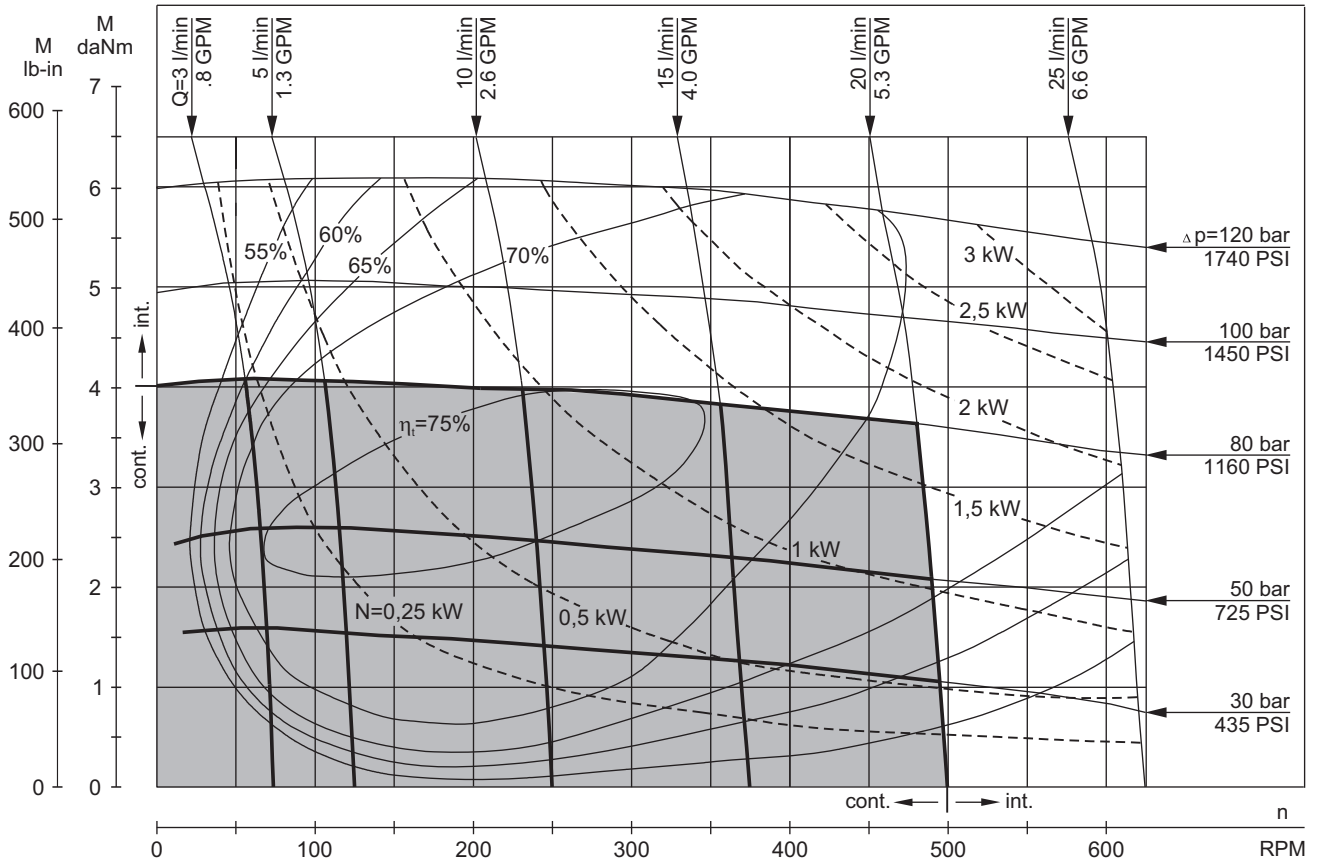

MM 50

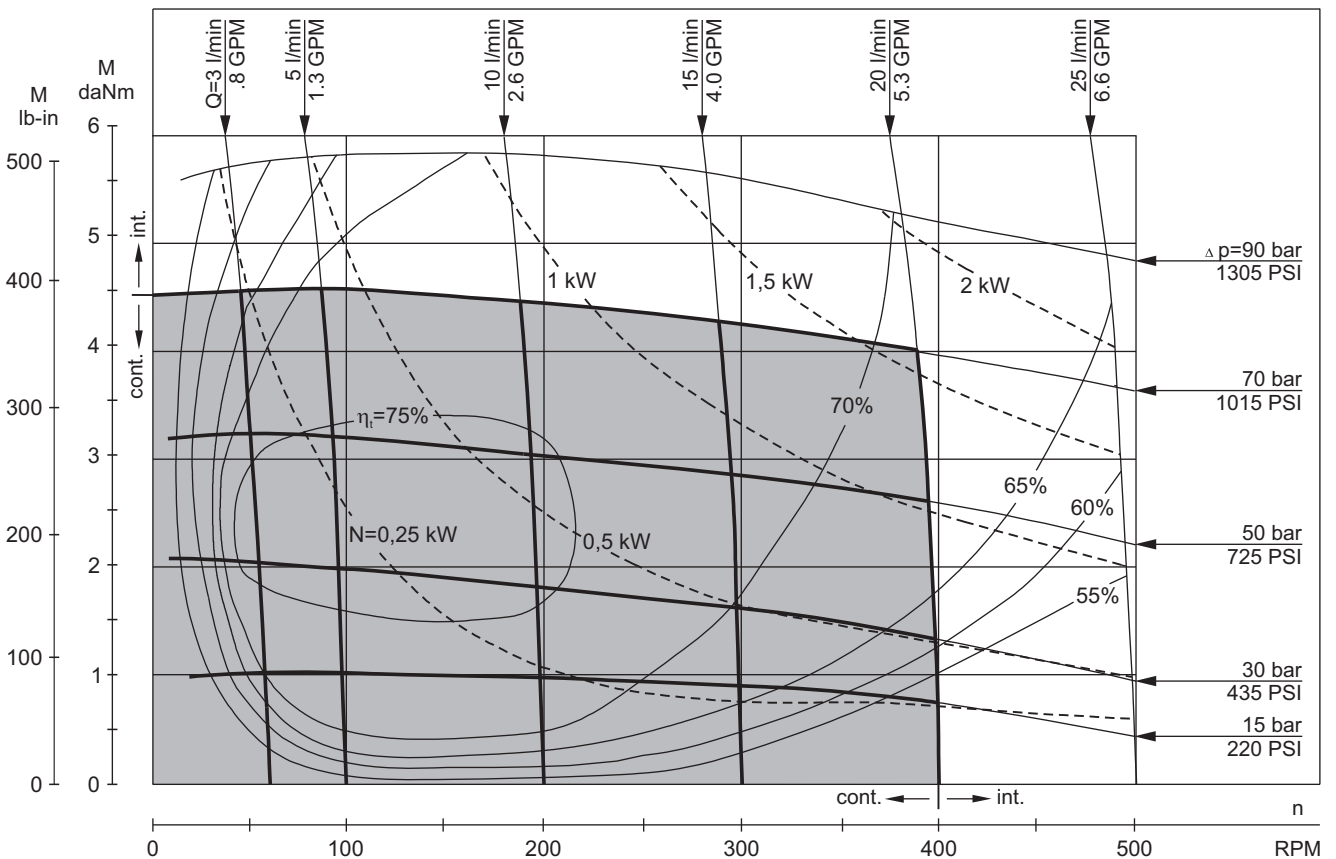

The function diagrams data is for average performance of randomly selected motors at back pressure 5 ± 10 bar [72.5 PSI-145 PSI] and oil with viscosity of $32 \text{ mm}^2/\text{s}$ [150 SUS] at 50°C [122°F].

DIMENSIONS and MOUNTING DATA
MM, MMS, MMP, MMD

Three Bolts Mount
SH Shaft C Shaft CK Shaft

F Oval Mount (2 Holes)

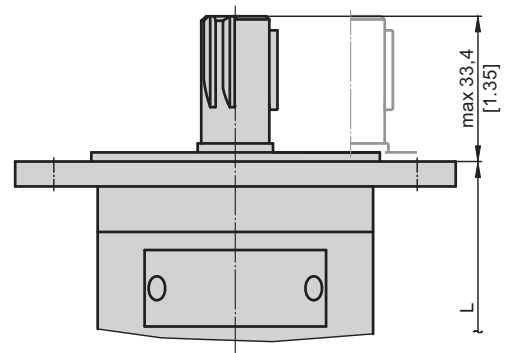
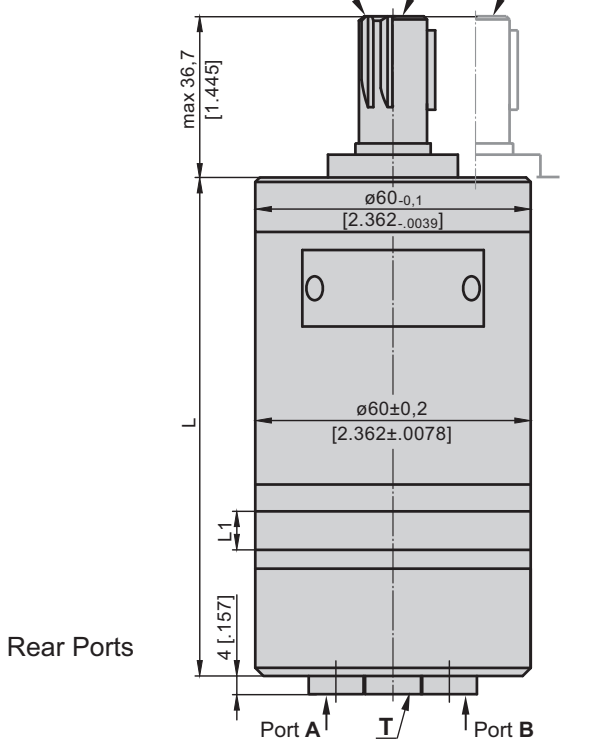

Rear Ports

Standard Rotation

Viewed from Shaft End

Port A Pressurized - **CW**

Port B Pressurized - **CCW**

Reverse Rotation

Viewed from Shaft End

Port A Pressurized - **CCW**

Port B Pressurized - **CW**

Port Dim.
See Page 10

S Side Ports

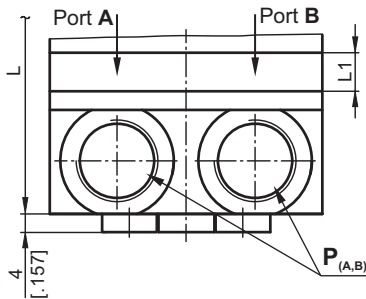

P_(A,B): 2xG3/8 or 2xM18x1,5 - 12 mm [.47 in] depth
T: G1/8 or M10x1 - 10 mm [.39 in] depth

P Side Ports

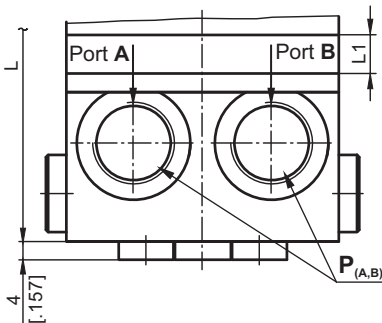

D Side Ports

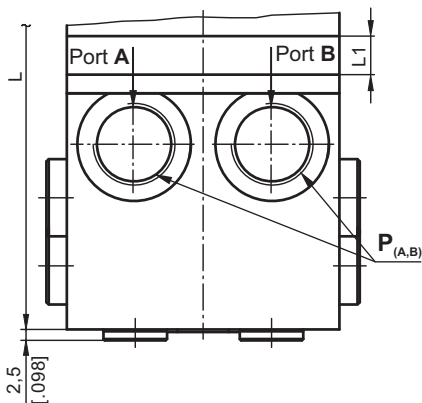

Type	L, mm [in]	Type	L, mm [in]	L ₁ , mm [in]
MM 8	105 [4.134]	MMS 8	106,4 [4.189]	3,5 [.138]
MM 12,5	107 [4.213]	MMS 12,5	108,4 [4.268]	5,5 [.217]
MM 20	110 [4.331]	MMS 20	111,4 [4.386]	8,5 [.335]
MM 32	115 [4.528]	MMS 32	116,4 [4.583]	13,5 [.531]
MM 40	118,5 [4.665]	MMS 40	119,9 [4.720]	17 [.669]
MM 50	122,5 [4.823]	MMS 50	123,9 [4.878]	21 [.827]

Type	L, mm [in]	Type	L, mm [in]	L ₁ , mm [in]
MMP 8	116 [4.567]	MMD 8	135,1 [5.319]	3,5 [.138]
MMP 12,5	118 [4.646]	MMD 12,5	137,1 [5.398]	5,5 [.217]
MMP 20	121 [4.764]	MMD 20	140,1 [5.516]	8,5 [.335]
MMP 32	126 [4.961]	MMD 32	145,1 [5.713]	13,5 [.531]
MMP 40	129,5 [5.098]	MMD 40	148,6 [5.850]	17 [.669]
MMP 50	133,5 [5.256]	MMD 50	152,6 [6.008]	21 [.827]

For "F" Flange +3,5 mm



MOUNTING

Three Bolts Mount

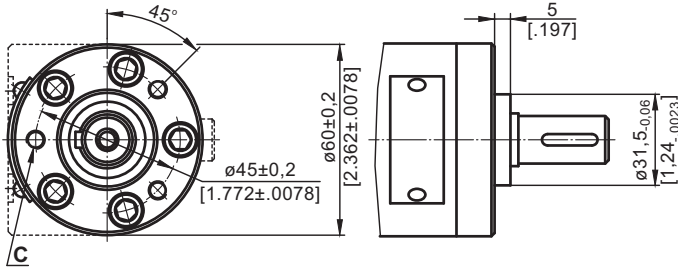

F Oval Mount (2 Holes)

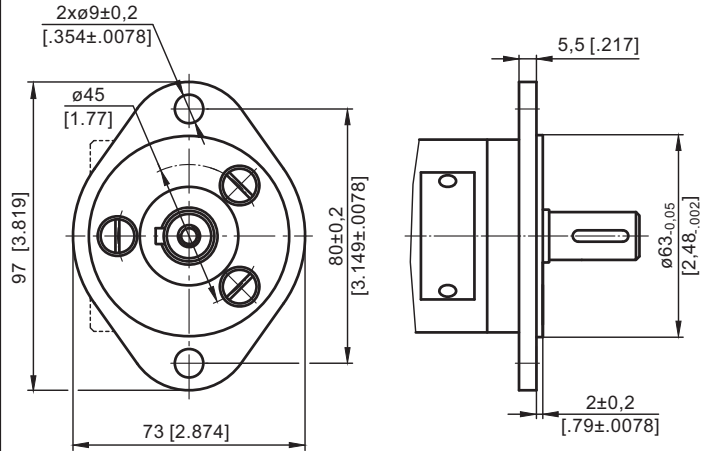

PORTS

Rear Ports

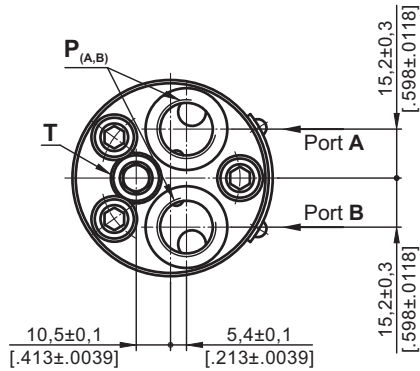

S Side Ports

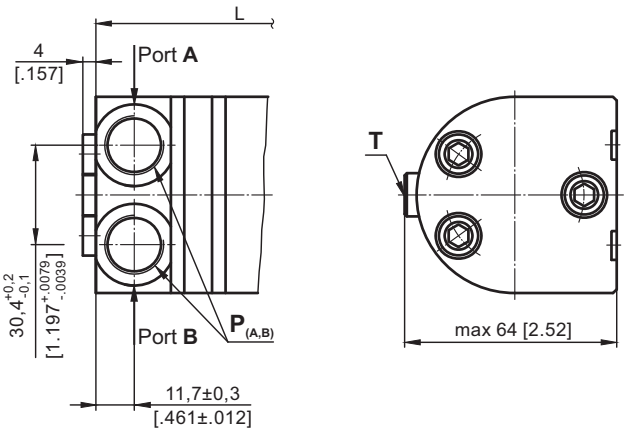

P Side Ports with Single Crossover Relief Valve

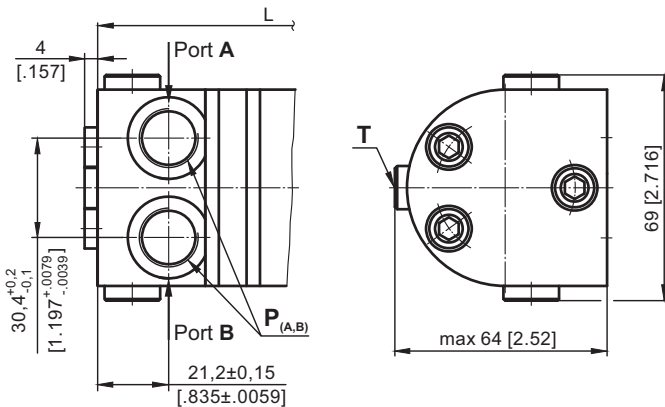

D Side Ports with Dual Crossover Relief Valve

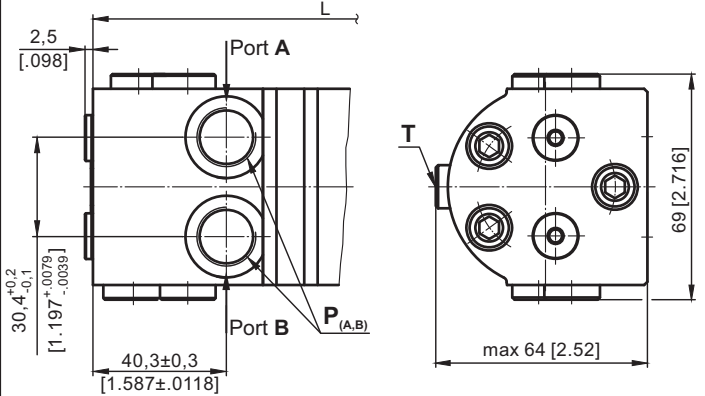

Standard Rotation
Viewed from Shaft End
Port A Pressurized - **CW**
Port B Pressurized - **CCW**

Reverse Rotation
Viewed from Shaft End
Port A Pressurized - **CCW**
Port B Pressurized - **CW**

C : 3xM6 - 12 mm [.47 in] depth
P_(A,B) : 2xG3/8 or 2xM18x1,5 - 12 mm [.47 in] depth
T : G1/8 or M10x1 - 10 mm [.39 in] depth

SHAFT EXTENSIONS

C - $\varnothing 16$ straight, Parallel key 5x5x16 DIN 6885
Max. Torque 3,9 daNm [345 lb-in]

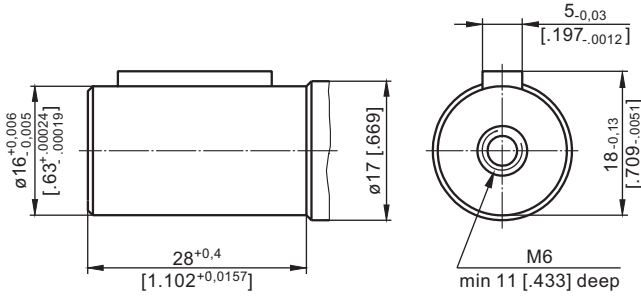

CK - $\varnothing 14$ straight, Parallel key 5x5x16 DIN 6885
Max. Torque 3 daNm [265 lb-in]

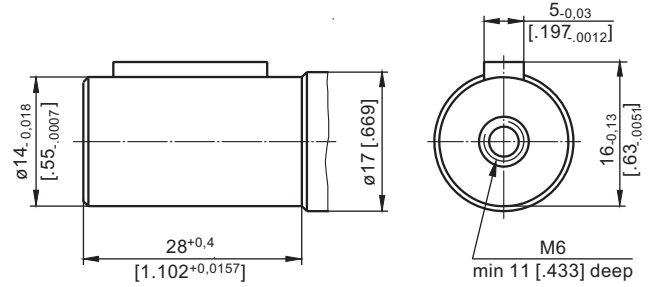

SH - $\varnothing 16,5$ splined, B17x14 DIN 5482
Max. Torque 4,4 daNm [390 lb-in]

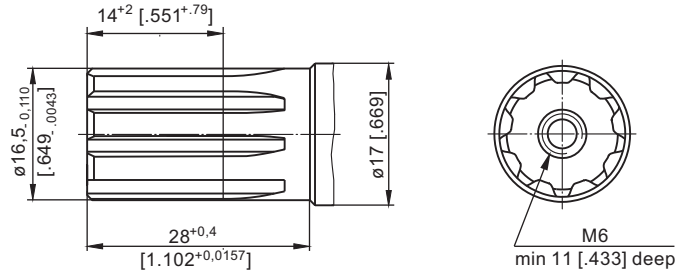

PERMISSIBLE SHAFT LOAD

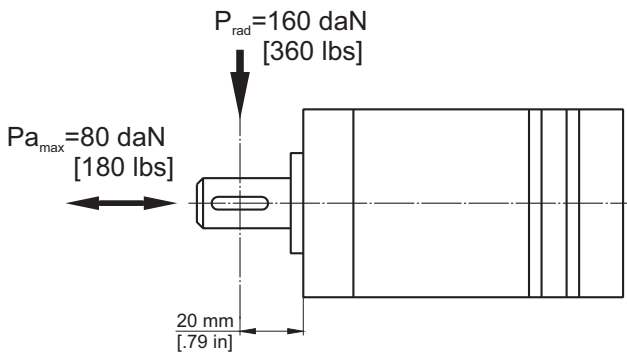

The permissible radial shaft load [Prad] is calculated from the distance [L] between the point of load application and the mounting surface:

$$P_{rad} = \frac{600}{n} \times \frac{13040}{61,5+L}, \text{ [daN]}$$

[L in mm; L ≤ 80 mm]

$$P_{rad} = \frac{600}{n} \times \frac{1155}{2,42 + L}, \text{ [lbs]}$$

[L in inch; L ≤ 3.15 in]

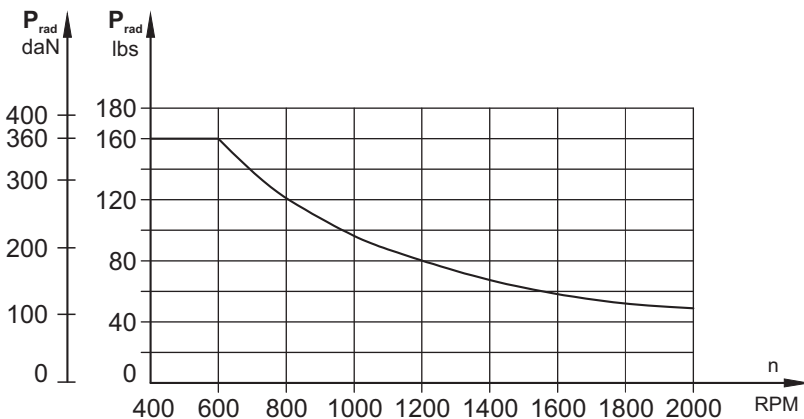

The drawing shows the permissible radial load when L=20 mm [0.79 in].

If the calculated shaft load exceeds the permissible, a flexible coupling must be used.

ORDER CODE

	1	2	3	4	5	6	7	8	9	10
M M										

Pos.1 - Adjustment Option

- omit - without valve
- P** - Side ports with single crossover relief valve
- D** - Side ports with dual crossover relief valve

Pos.2 - Mounting Flange

- omit - Three bolts mount valve
- F** - Oval mount, two holes

Pos.3 - Port type (not valid for P and D version)

- omit - Rear ports
- S** - Side ports

Pos.4 - Displacement code

- 8** - 8,2 cm³/rev [.5 in³/rev]
- 12.5** - 12,9 cm³/rev [.79 in³/rev]
- 20** - 20,0 cm³/rev [1.22 in³/rev]
- 32** - 31,8 cm³/rev [1.93 in³/rev]
- 40** - 40,0 cm³/rev [2.44 in³/rev]
- 50** - 50,0 cm³/rev [3.05 in³/rev]

Pos. 5 - Shaft Extensions*

- C** - ø16 straight, Parallel key A5x5x16 DIN6885
- VC** - ø16 straight, Parallel key A5x5x16 DIN6885 with corrosion resistant protection
- CK** - ø14 straight, Parallel key 5x5x16 DIN6885
- SH** - ø16,5 splined, B17x14 DIN 5482

Pos. 6 - Ports

- omit - BSPP (ISO 228)
- M** - Metric (ISO 262)

Pos. 7 - Line to control (see page 4)**

- /L** - B → A (left running)
- /R** - A → B (right running)

Pos. 8 - Valve Rated Pressure***

- /50** - Δp= 50 bar [725 PSI]
- /80** - Δp= 80 bar [1160 PSI]
- /100** - Δp=100 bar [1450 PSI]
- /140** - Δp=140 bar [2030 PSI]

Pos. 9 - Additional Options (see page 125)

Pos.10 - Design Series

- omit - Factory specified

NOTES: * The permissible output torque for shafts must not be exceeded!

** For P option useful only.

*** For P and D option useful only.

! **MMP** and **MMD** are available with new crossover relief valves with improved characteristics. The valves are set in a wide pressure range: from 50 bar [725 PSI] to 140 bar [2030 PSI]. For more information about MMP and MMD please contact with "M+S Hydraulic".

The Valve pressure setting must be at flow rate of 2 lpm [.53 GPM].

The hydraulic motors are mangan - phosphatized as standard.

F - FLANGE (2 Holes)

Order No for Flange:48443 014 00

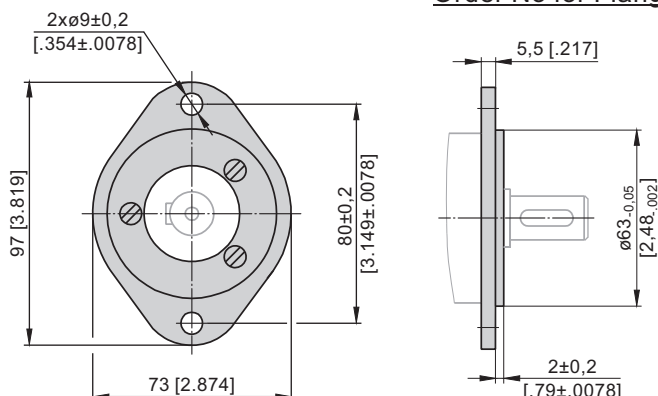

F Flange is mounted to the motor with 3 screws - M6x14. Tightening Torque: 5-6 Nm [44-53 lb-in].

HYDRAULIC MOTORS MP



APPLICATION

- » Conveyors
- » Feeding mechanism of robots and manipulators
- » Metal working machines
- » Textile machines
- » Agricultural machines
- » Food industries
- » Grass cutting machinery etc.

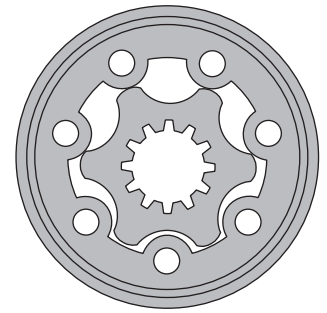

CONTENTS

Specification data	14+17
Function diagrams	18+24
Dimensions and mounting	25+26
Wheel motor	27
Shaft extensions	28
Permissible shaft loads	29
Permissible shaft seal pressure	30
Order code	31

OPTIONS

- » Model - Spool valve, gerotor
- » Flange and wheel mount
- » Motor with needle bearing
- » Side and rear ports
- » Shafts - straight, splined and tapered
- » Shaft seal for high and low pressure
- » Metric and BSPP ports
- » Speed sensing
- » Other special features

GENERAL

Max. Displacement, cm ³ /rev [in ³ /rev]	623,6 [38.05]
Max. Speed, [RPM]	1815
Max. Torque, daNm [lb-in]	cont.:50 [4415] int.: 64 [5565]
Max. Output, kW [HP]	12,8 [17.1]
Max. Pressure Drop, bar [PSI]	cont.:140 [2030] int.: 175 [2540]
Max. Oil Flow, lpm [GPM]	75 [19.8]
Min. Speed, [RPM]	10
Pressure fluid	Mineral based- HLP(DIN 51524) or HM(ISO 6743/4)
Temperature range, °C [°F]	-40÷140 [-40÷284]
Optimal Viscosity range, mm ² /s [SUS]	20÷75 [98÷347]
Filtration	ISO code: 18/16/13 According to ISO 4406-1999

Oil flow in drain line

Pressure drop bar [PSI]	Viscosity mm ² /s [SUS]	Oil flow in drain line lpm [GPM]
100 [1450]	20 [98]	2,5 [.660]
	35 [164]	1,8 [.476]
140 [2030]	20 [98]	3,5 [.925]
	35 [164]	2,8 [.740]

Pressure Losses

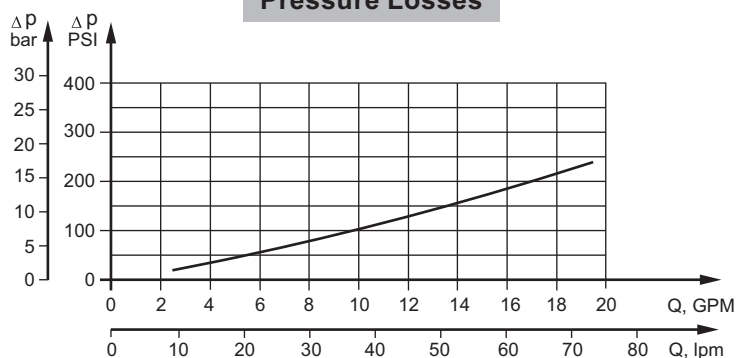

SPECIFICATION DATA

Specification Data for MP... motors with **C, CO, SH, K** and **SA** shafts.
(ø28,56 sealing diameter)

Type		MP 25	MP 32	MP 40	MP 50	MP 63	MP 80	MP 100	MP 125
Displacement, cm³/rev [in³/rev]		28,4 [1.73]	34,5 [2.1]	40,5 [2.47]	49,5 [3.02]	62,3 [3.8]	79,2 [4.83]	99 [6.04]	123,8 [7.55]
Max. Speed, [RPM]	Cont.	1408	1450	1480	1210	960	755	605	486
	Int.*	1584	1594	1555	1515	1200	945	755	605
Max. Torque, daNm [lb-in]	Cont.	3,3 [290]	4,3 [380]	6,2 [550]	9,4 [835]	11,8 [1044]	15,1 [1340]	19,3 [1710]	23,7 [2100]
	Int.*	4,7 [415]	6,1 [540]	8,2 [730]	11,9 [1050]	14,7 [1300]	19,5 [1725]	23,7 [2100]	29,8 [2640]
	Peak**	6,7 [595]	8,6 [760]	10,7 [950]	14,3 [1285]	12,2 [1080]	22,4 [1985]	27,5 [2435]	36,5 [3235]
Max. Output, kW [HP]	Cont.	4,5 [6.0]	4,5 [6.0]	8,4 [11.5]	10,1 [13.5]	10,1 [13.5]	10,2 [13.7]	10,5 [14.1]	10,2 [13.7]
	Int.*	6,1 [8.2]	7,8 [10.5]	11,6 [15.5]	12,2 [16.1]	12,2 [16.1]	12,5 [16.8]	12,8 [17.1]	12 [16.1]
Max. Pressure Drop, bar [PSI]	Cont.	100 [1450]	100 [1450]	120 [1750]	140 [2030]	140 [2030]	140 [2030]	140 [2030]	140 [2030]
	Int.*	140 [2030]	140 [2030]	155 [2250]	175 [2540]	175 [2540]	175 [2540]	175 [2540]	175 [2540]
	Peak**	225 [3260]	225 [3260]	225 [3260]	225 [3260]	225 [3260]	225 [3260]	225 [3260]	225 [3260]
Max. Oil Flow, lpm [GPM]	Cont.	40 [10.5]	50 [13.2]	60 [15.9]	60 [15.9]	60 [15.9]	60 [15.9]	60 [15.9]	60 [15.9]
	Int.*	45 [11.9]	55 [14.5]	70 [18.5]	75 [19.8]	75 [19.8]	75 [19.8]	75 [19.8]	75 [19.8]
Max. Inlet Pressure, bar [PSI]	Cont.	175 [2540]	175 [2540]	175 [2540]	175 [2540]	175 [2540]	175 [2540]	175 [2540]	175 [2540]
	Int.*	200 [2900]	200 [2900]	200 [2900]	200 [2900]	200 [2900]	200 [2900]	200 [2900]	200 [2900]
	Peak**	225 [3260]	225 [3260]	225 [3260]	225 [3260]	225 [3260]	225 [3260]	225 [3260]	225 [3260]
Max. Return Pressure with Drain Line, bar [PSI]	Cont.	175 [2540]	175 [2540]	175 [2540]	175 [2540]	175 [2540]	175 [2540]	175 [2540]	175 [2540]
	Int.*	200 [2900]	200 [2900]	200 [2900]	200 [2900]	200 [2900]	200 [2900]	200 [2900]	200 [2900]
	Peak**	225 [3260]	225 [3260]	225 [3260]	225 [3260]	225 [3260]	225 [3260]	225 [3260]	225 [3260]
Max. Starting Pressure with Unloaded Shaft, bar [PSI]		10 [145]	10 [145]	10 [145]	10 [145]	10 [145]	10 [145]	10 [145]	9 [131]
Min. Starting Torque, daNm [lb-in]	At max.press. drop Cont.	3,0 [265]	4,0 [355]	5,4 [480]	7,8 [690]	7,8 [690]	13,2 [1170]	16,6 [1470]	20,7 [1830]
	At max.press. drop Int.*	4,2 [370]	5,6 [500]	6,8 [600]	10 [885]	10 [885]	16,8 [1490]	21 [1860]	26,6 [2360]
Min. Speed***, [RPM]		20	15		10	10	10	10	10
Weight, kg [lb] For rear ports: +0,450 [.992]	MP(F)(N)	5,6 [12.3]	5,6 [12.3]	5,7 [12.6]	5,8 [12.8]	5,8 [12.8]	5,9 [13.2]	6,1 [13.5]	6,2 [13.7]
	MPW(N)	5,3 [11.7]	5,3 [11.7]	5,4 [11.9]	5,5 [12.1]	5,5 [12.1]	5,6 [12.4]	5,8 [12.8]	5,9 [13.2]
	MPQ(N)	5,0 [11.1]	5,0 [11.1]	5,1 [11.2]	5,2 [11.5]	5,2 [11.5]	5,3 [11.7]	5,5 [12.1]	5,6 [12.4]

* Intermittent operation: the permissible values may occur for max. 10% of every minute.

** Peak load: the permissible values may occur for max. 1% of every minute.

*** For speeds lower than given, consult factory or your regional manager.

- Intermittent speed and intermittent pressure must not occur simultaneously.
- Recommended filtration is per ISO cleanliness code 20/16. A nominal filtration of 25 micron or better.
- Recommend using a premium quality, anti-wear type mineral based hydraulic oil HLP(DIN51524) or HM (ISO 6743/4).
If using synthetic fluids consult the factory for alternative seal materials.
- Recommended minimum oil viscosity 13 mm²/s [70 SUS] at 50°C [122°F].
- Recommended maximum system operating temperature is 82°C [180°F].
- To assure optimum motor life fill with fluid prior to loading and run at moderate load and speed for 10-15 minutes.

SPECIFICATION DATA (continued)

Specification Data for MP... motors with **C, CO, SH, K** and **SA** shafts.
(ø28,56 sealing diameter)

Type		MP 160	MP 200	MP 250	MP 315	MP 400	MP 500	MP 630
Displacement, cm³/rev [in³/rev]		158,4 [9.66]	198 [12.1]	247,5 [15.1]	316,8 [19.3]	396 [24.16]	495 [30.2]	623,6 [38.05]
Max. Speed, [RPM]	Cont.	378	303	242	190	150	120	95
	Int.*	472	378	303	236	189	150	120
Max. Torque, daNm [lb-in]	Cont.	31,3 [2770]	36,6 [3240]	38 [3360]	38 [3360]	36 [3190]	39 [3452]	44 [3895]
	Int.*	37,8 [3345]	45,6 [4035]	58,3 [5160]	56 [4960]	59 [5240]	57 [5045]	64 [5665]
	Peak**	43,8 [3880]	55 [4870]	68,5 [6060]	85 [7505]	85,4 [7560]	78 [6903]	82 [7257]
Max. Output, kW [HP]	Cont.	10,1 [13.5]	10 [13.5]	7,5 [10]	5,8 [7.9]	4,6 [6.2]	3,5 [4.7]	3,3 [4.4]
	Int.*	12,1 [16.2]	12 [16.1]	12 [16.1]	9 [12.1]	7,8 [10.5]	7,2 [9.7]	5,6 [7.5]
Max. Pressure Drop, bar [PSI]	Cont.	140 [2030]	140 [2030]	110 [1600]	90 [1300]	70 [1015]	60 [870]	55 [800]
	Int.*	175 [2540]	175 [2540]	175 [2540]	140 [2030]	115 [1665]	90 [1305]	80 [1160]
	Peak**	225 [3260]	225 [3260]	225 [3260]	225 [3260]	180 [2610]	130 [1885]	110 [1740]
Max. Oil Flow, lpm [GPM]	Cont.	60 [15.9]	60 [15.9]	60 [15.9]	60 [15.9]	60 [15.9]	60 [15.9]	60 [15.9]
	Int.*	75 [19.8]	75 [19.8]	75 [19.8]	75 [19.8]	75 [19.8]	75 [19.8]	75 [19.8]
Max. Inlet Pressure, bar [PSI]	Cont.	175 [2540]	175 [2540]	175 [2540]	175 [2540]	175 [2540]	140 [2030]	140 [2030]
	Int.*	200 [2900]	200 [2900]	200 [2900]	200 [2900]	200 [2900]	175 [2540]	175 [2540]
	Peak**	225 [3260]	225 [3260]	225 [3260]	225 [3260]	225 [3260]	225 [3260]	225 [3260]
Max. Return Pressure with Drain Line, bar [PSI]	Cont.	175 [2540]	175 [2540]	175 [2540]	175 [2540]	175 [2540]	140 [2030]	140 [2030]
	Int.*	200 [2900]	200 [2900]	200 [2900]	200 [2900]	200 [2900]	175 [2540]	175 [2540]
	Peak**	225 [3260]	225 [3260]	225 [3260]	225 [3260]	225 [3260]	225 [3260]	225 [3260]
Max. Starting Pressure with Unloaded Shaft, bar [PSI]		8 [116]	7 [100]	6 [87]	5 [73]	5 [73]	5 [73]	5 [73]
Min. Starting Torque, daNm [lb-in]	At max.press. drop Cont.	28,2 [2500]	33,5 [2950]	33,6 [2970]	34,4 [3045]	34,5 [3050]	36 [3180]	41,5 [3670]
	At max.press. drop Int.*	35,5 [3140]	42,6 [3770]	54,2 [4795]	61,9 [5480]	60,8 [5390]	54 [4780]	62 [5480]
Min. Speed***, [RPM]		10	10	10	10	10	10	10
Weight, kg [lb] For rear ports: +0,450 [.992]	MP(F)(N)	6,4 [14.1]	6,6 [14.6]	6,8 [15]	7,1 [15.6]	7,6 [16.8]	8,9 [20]	9,5 [21.4]
	MPW(N)	6,1 [13.5]	6,3 [13.9]	6,5 [14.3]	6,8 [15]	7,2 [15.9]	8,6 [19]	9,2 [20.3]
	MPQ(N)	5,8 [12.8]	6 [13.2]	6,2 [13.7]	6,5 [14.3]	6,8 [15]	8,3 [18.3]	9 [19.8]

* Intermittent operation: the permissible values may occur for max. 10% of every minute.

** Peak load: the permissible values may occur for max. 1% of every minute.

*** For speeds lower than given, consult factory or your regional manager.

- Intermittent speed and intermittent pressure must not occur simultaneously.
- Recommended filtration is per ISO cleanliness code 20/16. A nominal filtration of 25 micron or better.
- Recommend using a premium quality, anti-wear type mineral based hydraulic oil HLP(DIN51524) or HM (ISO 6743/4).
If using synthetic fluids consult the factory for alternative seal materials.
- Recommended minimum oil viscosity 13 mm²/s [70 SUS] at 50°C [122°F].
- Recommended maximum system operating temperature is 82°C [180°F].
- To assure optimum motor life fill with fluid prior to loading and run at moderate load and speed for 10-15 minutes.

SPECIFICATION DATA (continued)

Specification Data for MP... motors with **CB, KB, OB** and **HB** shafts.
(ø35 sealing diameter)

Type		MP 80	MP 100	MP 125	MP 160	MP 200
Displacement, cm³/rev [in³/rev]		79,2 [4.83]	99 [6.04]	123,8 [7.55]	158,4 [9.66]	198 [12.1]
Max. Speed, [RPM]	Cont.	755	605	486	378	303
	Int.*	945	755	605	472	378
Max. Torque, daNm [lb-in]	Cont.	15,1 [1340]	19,3 [1710]	23,7 [2100]	31,3 [2770]	36,6 [3240]
	Int.*	19,5 [1725]	23,7 [2100]	29,8 [2640]	37,8 [3345]	45,6 [4035]
	Peak**	22,4 [1985]	27,5 [2435]	36,5 [3235]	43,8 [3880]	55 [4870]
Max. Output, kW [HP]	Cont.	10,2 [13.7]	10,5 [14.1]	10,2 [13.7]	10,1 [13.5]	10 [13.5]
	Int.*	12,5 [16.8]	12,8 [17.1]	12 [16.1]	12,1 [16.2]	12 [16.1]
Max. Pressure Drop, bar [PSI]	Cont.	140 [2030]	140 [2030]	140 [2030]	140 [2030]	140 [2030]
	Int.*	175 [2540]	175 [2540]	175 [2540]	175 [2540]	175 [2540]
	Peak**	225 [3260]	225 [3260]	225 [3260]	225 [3260]	225 [3260]
Max. Oil Flow, lpm [GPM]	Cont.	60 [15.9]	60 [15.9]	60 [15.9]	60 [15.9]	60 [15.9]
	Int.*	75 [19.8]	75 [19.8]	75 [19.8]	75 [19.8]	75 [19.8]
Max. Inlet Pressure, bar [PSI]	Cont.	175 [2540]	175 [2540]	175 [2540]	175 [2540]	175 [2540]
	Int.*	200 [2900]	200 [2900]	200 [2900]	200 [2900]	200 [2900]
	Peak**	225 [3260]	225 [3260]	225 [3260]	225 [3260]	225 [3260]
Max. Return Pressure with Drain Line, bar [PSI]	Cont.	175 [2540]	175 [2540]	175 [2540]	175 [2540]	175 [2540]
	Int.*	200 [2900]	200 [2900]	200 [2900]	200 [2900]	200 [2900]
	Peak**	225 [3260]	225 [3260]	225 [3260]	225 [3260]	225 [3260]
Max. Starting Pressure with Unloaded Shaft, bar [PSI]		10 [145]	10 [145]	9 [131]	8 [116]	7 [100]
Min. Starting Torque, daNm [lb-in]	At max.press. drop Cont.	13,2 [1170]	16,6 [1470]	20,7 [1830]	28,2 [2500]	33,5 [2950]
	At max.press. drop Int.*	16,8 [1490]	21 [1860]	26,6 [2360]	35,5 [3140]	42,6 [3770]
Min. Speed***, [RPM]		10	10	10	10	10
Weight, kg [lb]	MP(F)...B	6 [13.2]	6,2 [13.7]	6,3 [13.9]	6,5 [14.3]	6,7 [14.8]
For rear ports: +0,450 [.992]						

* Intermittent operation: the permissible values may occur for max. 10% of every minute.

** Peak load: the permissible values may occur for max. 1% of every minute.

*** For speeds lower than given, consult factory or your regional manager.

- Intermittent speed and intermittent pressure must not occur simultaneously.
- Recommended filtration is per ISO cleanliness code 20/16. A nominal filtration of 25 micron or better.
- Recommend using a premium quality, anti-wear type mineral based hydraulic oil HLP(DIN51524) or HM (ISO 6743/4).
If using synthetic fluids consult the factory for alternative seal materials.
- Recommended minimum oil viscosity 13 mm²/s [70 SUS] at 50°C [122°F].
- Recommended maximum system operating temperature is 82°C [180°F].
- To assure optimum motor life fill with fluid prior to loading and run at moderate load and speed for 10-15 minutes.

SPECIFICATION DATA (continued)

Specification Data for MP... motors with **CB, KB, OB** and **HB** shafts.
($\varnothing 35$ sealing diameter)

Type		MP 250	MP 315	MP 400	MP 500	MP 630
Displacement, cm³/rev [in³/rev]		247,5 [15.1]	316,8 [19.3]	396 [24.16]	495 [30.2]	623,6 [38.05]
Max. Speed, [RPM]	Cont.	242	190	150	120	95
	Int.*	303	236	189	150	120
Max. Torque, daNm [lb-in]	Cont.	47 [4160]	48 [4360]	50 [4415]	39 [3452]	44 [3895]
	Int.*	58,3 [5160]	56 [4960]	59 [5240]	57 [5045]	64 [5665]
	Peak**	68,5 [6060]	85 [7505]	85,4 [7560]	78 [6903]	82 [7257]
Max. Output, kW [HP]	Cont.	9 [12.1]	7,6 [10.2]	6,2 [8.3]	3,5 [4.7]	3,3 [4.4]
	Int.*	12 [16.1]	9 [12.1]	7,8 [10.5]	7,2 [9.7]	5,6 [7.5]
Max. Pressure Drop, bar [PSI]	Cont.	140 [2030]	120 [1740]	95 [1400]	60 [870]	55 [800]
	Int.*	175 [2540]	140 [2030]	115 [1670]	90 [1305]	80 [1160]
	Peak**	225 [3260]	225 [3260]	180 [2610]	130 [1885]	110 [1740]
Max. Oil Flow, lpm [GPM]	Cont.	60 [15.9]	60 [15.9]	60 [15.9]	60 [15.9]	60 [15.9]
	Int.*	75 [19.8]	75 [19.8]	75 [19.8]	75 [19.8]	75 [19.8]
Max. Inlet Pressure, bar [PSI]	Cont.	175 [2540]	175 [2540]	175 [2540]	140 [2030]	140 [2030]
	Int.*	200 [2900]	200 [2900]	200 [2900]	175 [2540]	175 [2540]
	Peak**	225 [3260]	225 [3260]	225 [3260]	225 [3260]	225 [3260]
Max. Return Pressure with Drain Line, bar [PSI]	Cont.	175 [2540]	175 [2540]	175 [2540]	140 [2030]	140 [2030]
	Int.*	200 [2900]	200 [2900]	200 [2900]	175 [2540]	175 [2540]
	Peak**	225 [3260]	225 [3260]	225 [3260]	225 [3260]	225 [3260]
Max. Starting Pressure with Unloaded Shaft, bar [PSI]		6 [87]	5 [73]	5 [73]	5 [73]	5 [73]
Min. Starting Torque, daNm [lb-in]	At max.press. drop Cont.	42,8 [3790]	45,8 [4050]	46,8 [4140]	36 [3180]	41,5 [3670]
	At max.press. drop Int.*	54,2 [4795]	61,9 [5480]	60,8 [5390]	54 [4780]	62 [5480]
Min. Speed***, [RPM]		10	10	10	10	10
Weight, kg [lb]	MP(F)...B	6,9 [15.2]	7,2 [15.9]	7,7 [17]	9,0 [19.9]	9,6 [21.2]
For rear ports: +0,450 [.992]						

* Intermittent operation: the permissible values may occur for max. 10% of every minute.

** Peak load: the permissible values may occur for max. 1% of every minute.

*** For speeds lower than given, consult factory or your regional manager.

- Intermittent speed and intermittent pressure must not occur simultaneously.
- Recommended filtration is per ISO cleanliness code 20/16. A nominal filtration of 25 micron or better.
- Recommend using a premium quality, anti-wear type mineral based hydraulic oil HLP(DIN51524) or HM (ISO 6743/4).
If using synthetic fluids consult the factory for alternative seal materials.
- Recommended minimum oil viscosity 13 mm²/s [70 SUS] at 50°C [122°F].
- Recommended maximum system operating temperature is 82°C [180°F].
- To assure optimum motor life fill with fluid prior to loading and run at moderate load and speed for 10-15 minutes.

FUNCTION DIAGRAMS

MP 25

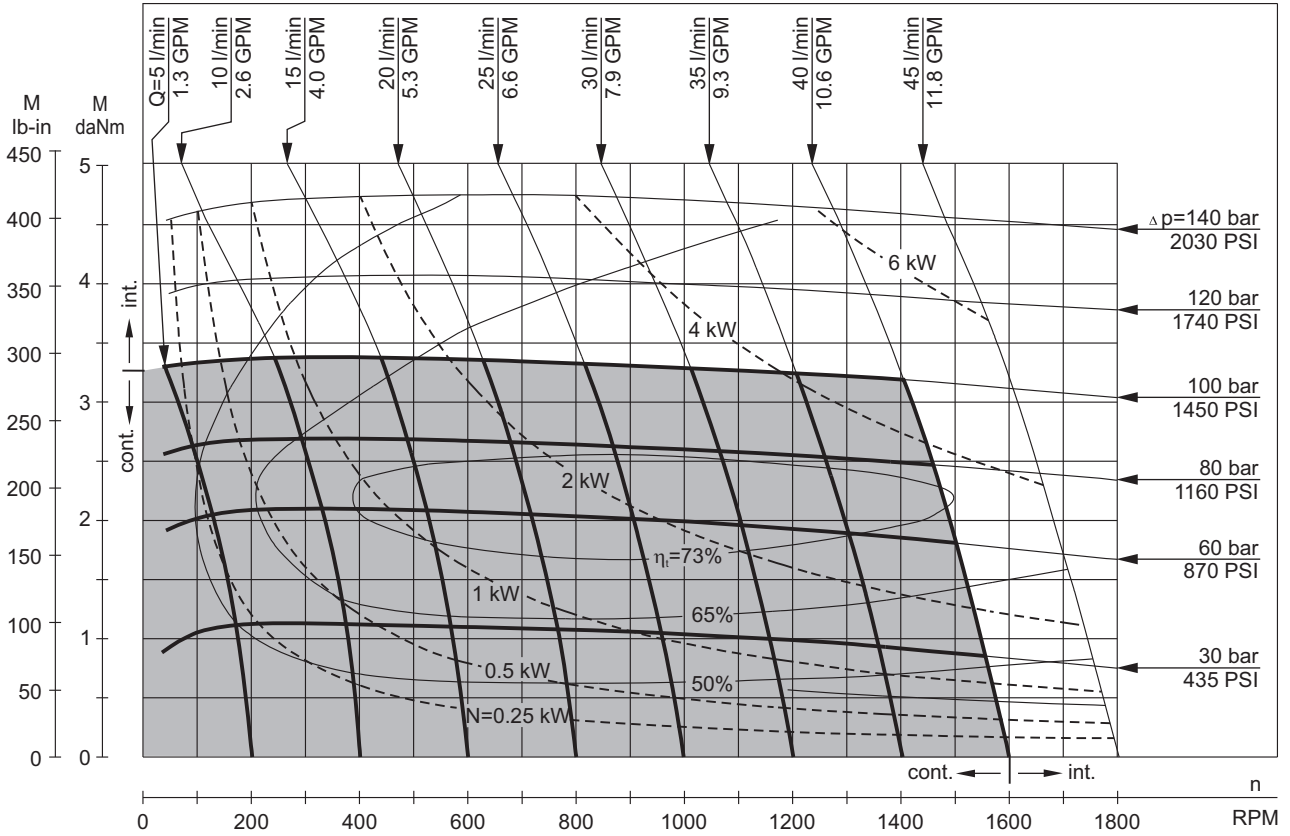

MP 32

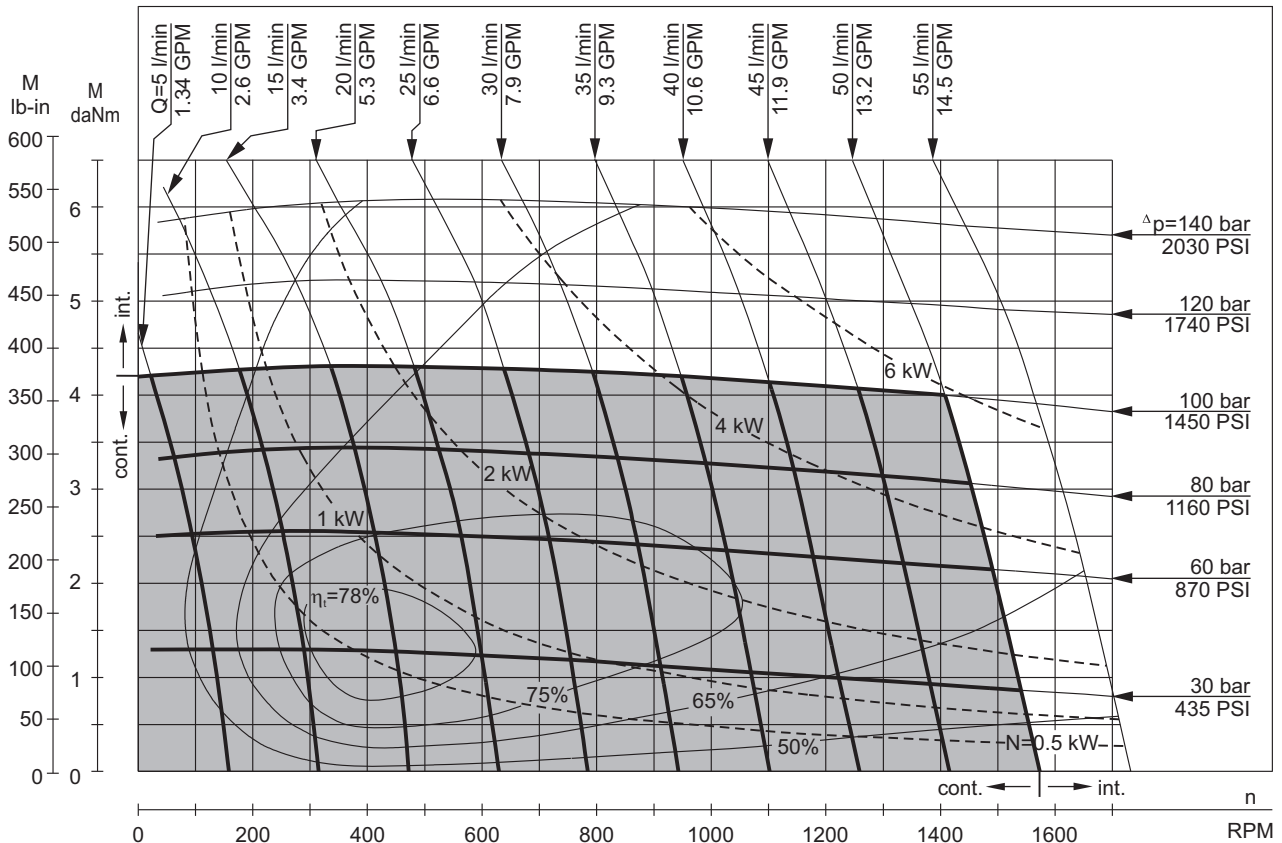

The function diagrams data is for average performance of randomly selected motors at back pressure 5±10 bar [72.5 PSI±145 PSI] and oil with viscosity of 32 mm²/s [150 SUS] at 50°C [122°F].

FUNCTION DIAGRAMS

MP 40

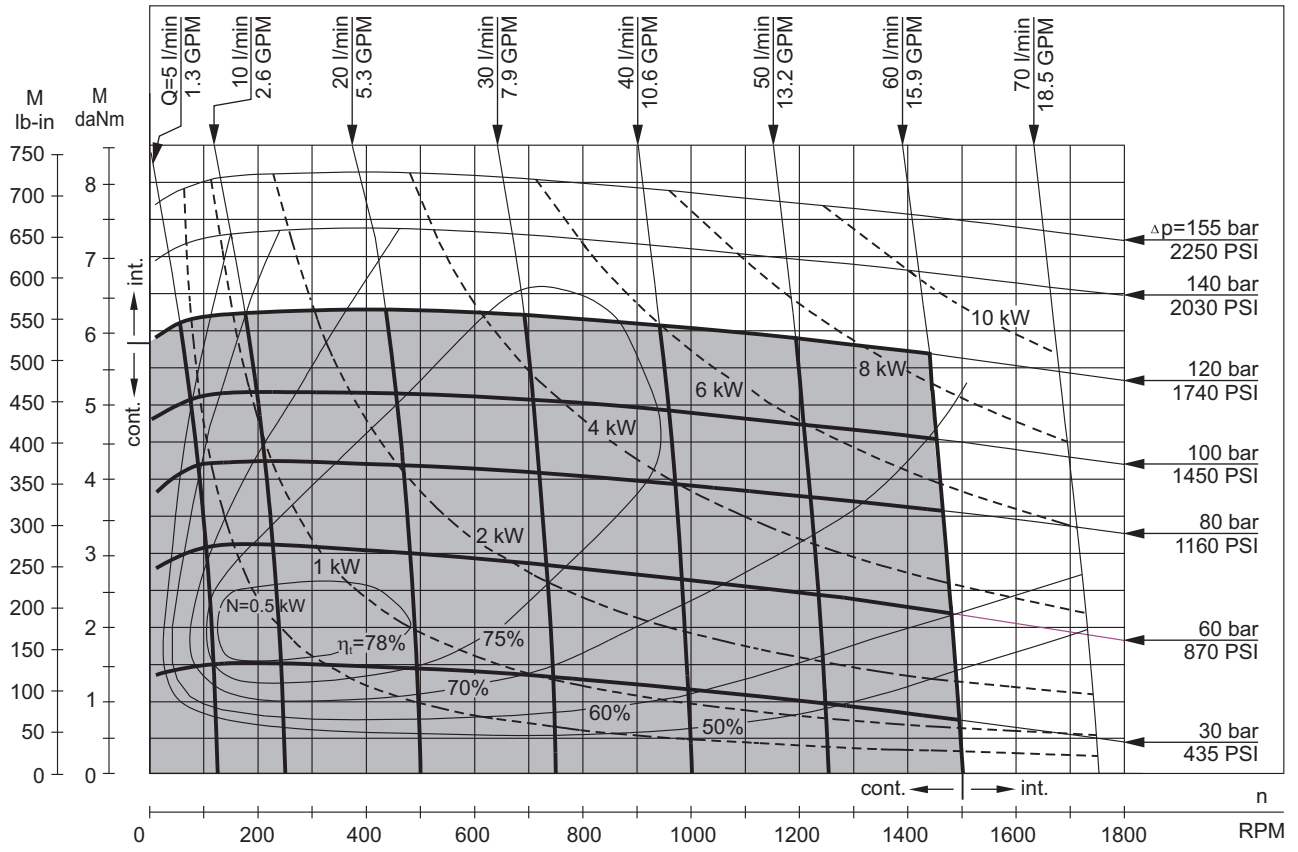

MP 50

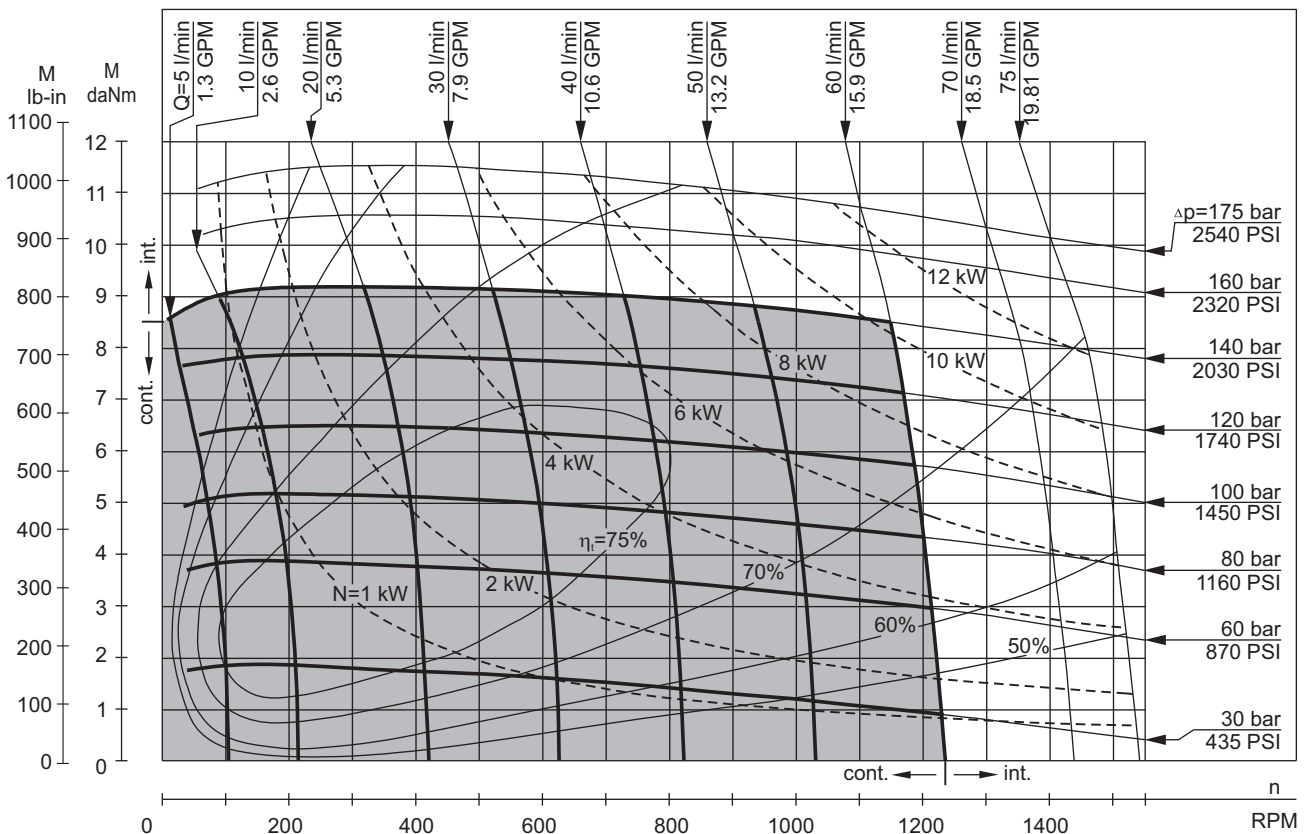

The function diagrams data is for average performance of randomly selected motors at back pressure 5±10 bar [72.5 PSI±145 PSI] and oil with viscosity of 32 mm²/s [150 SUS] at 50°C [122°F].

FUNCTION DIAGRAMS

MP 80

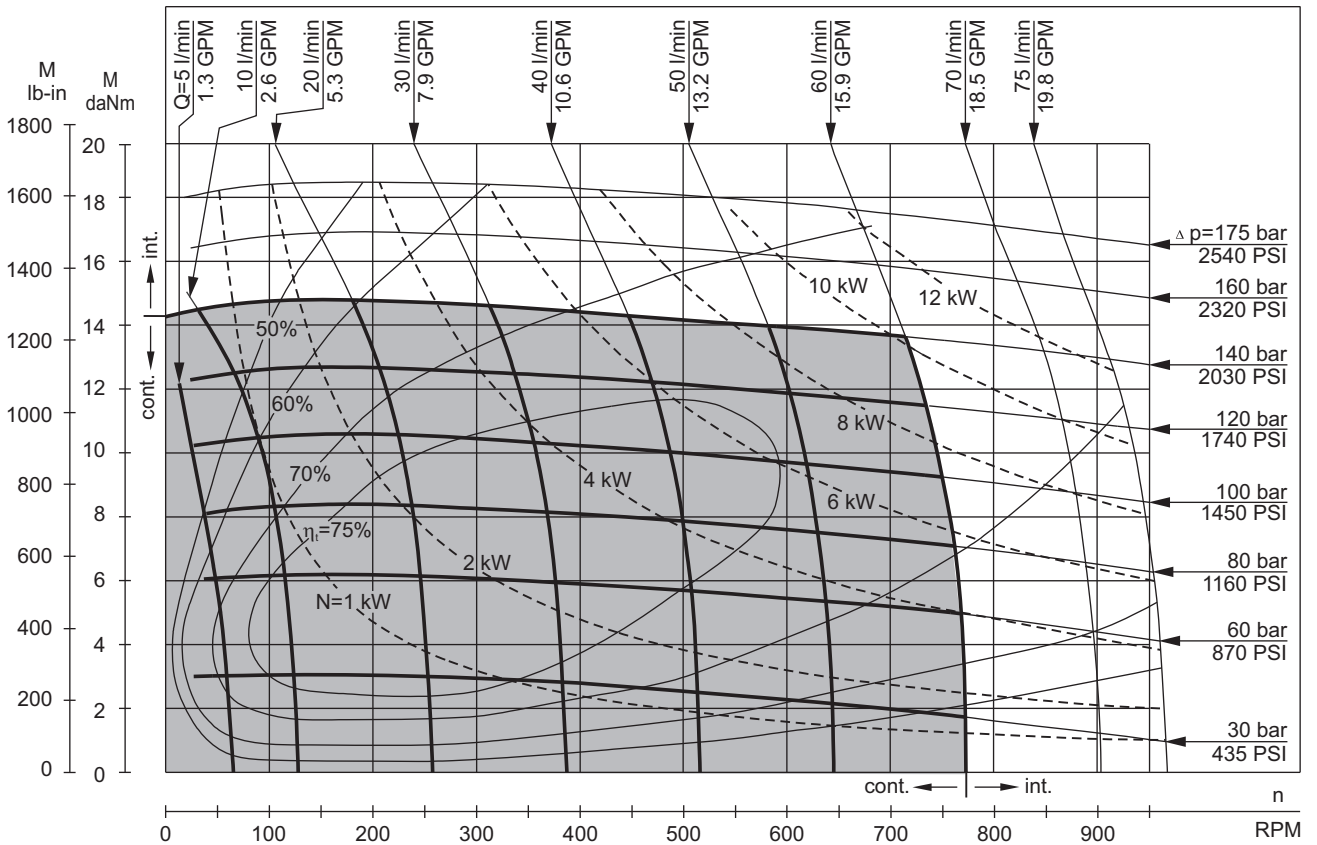

MP 100

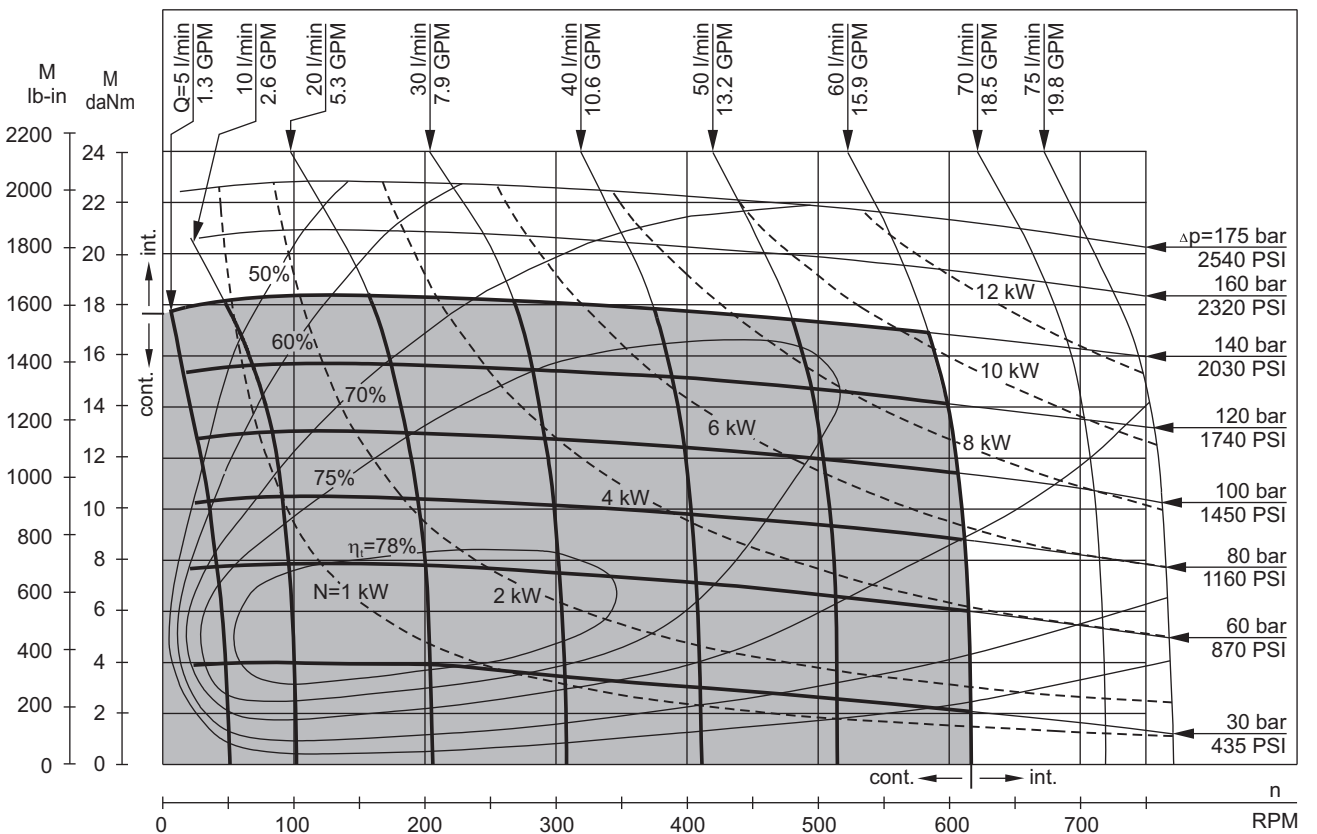

The function diagrams data is for average performance of randomly selected motors at back pressure 5±10 bar [72.5 PSI±145 PSI] and oil with viscosity of 32 mm²/s [150 SUS] at 50°C [122°F].

FUNCTION DIAGRAMS

MP 125

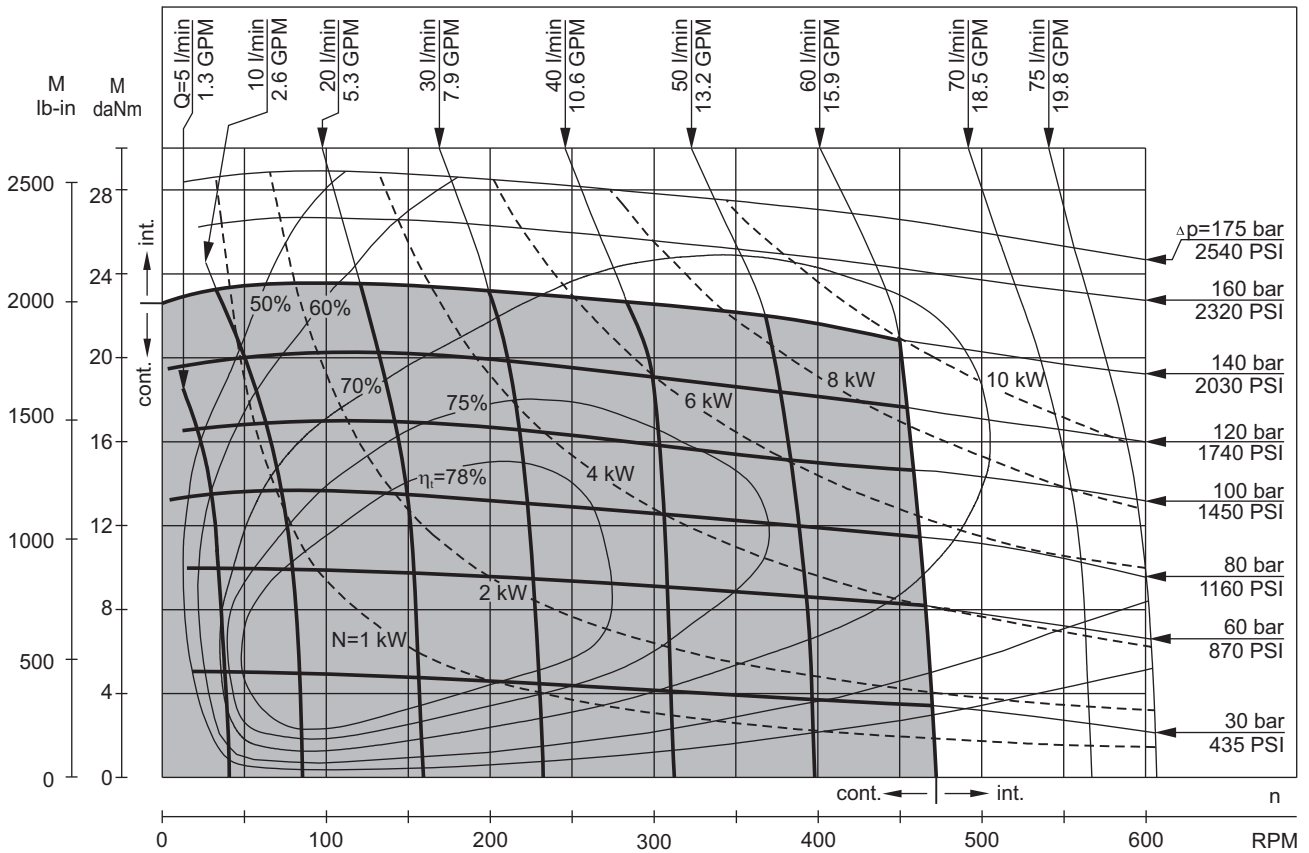

MP 160

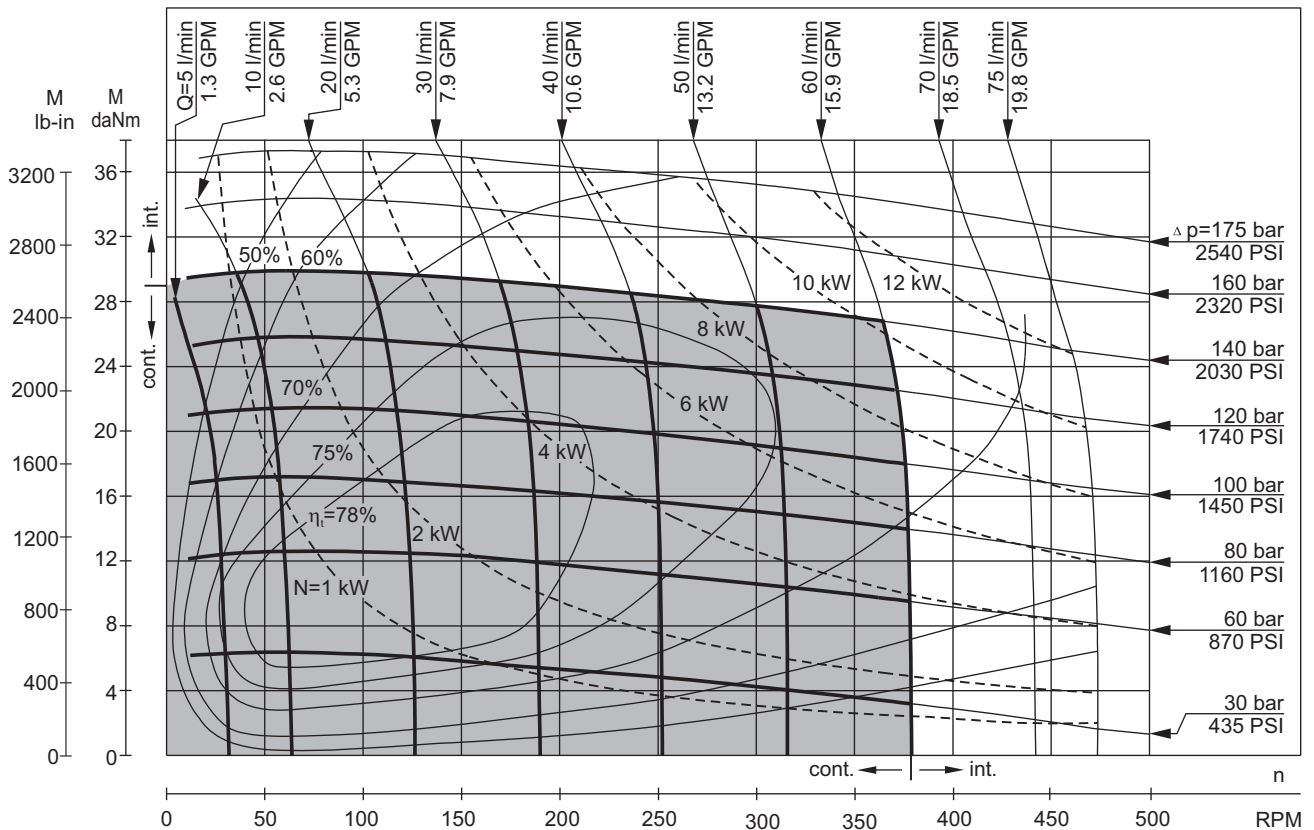

The function diagrams data is for average performance of randomly selected motors at back pressure 5±10 bar [72.5 PSI±145 PSI] and oil with viscosity of 32 mm²/s [150 SUS] at 50°C [122°F].

FUNCTION DIAGRAMS

MP 200

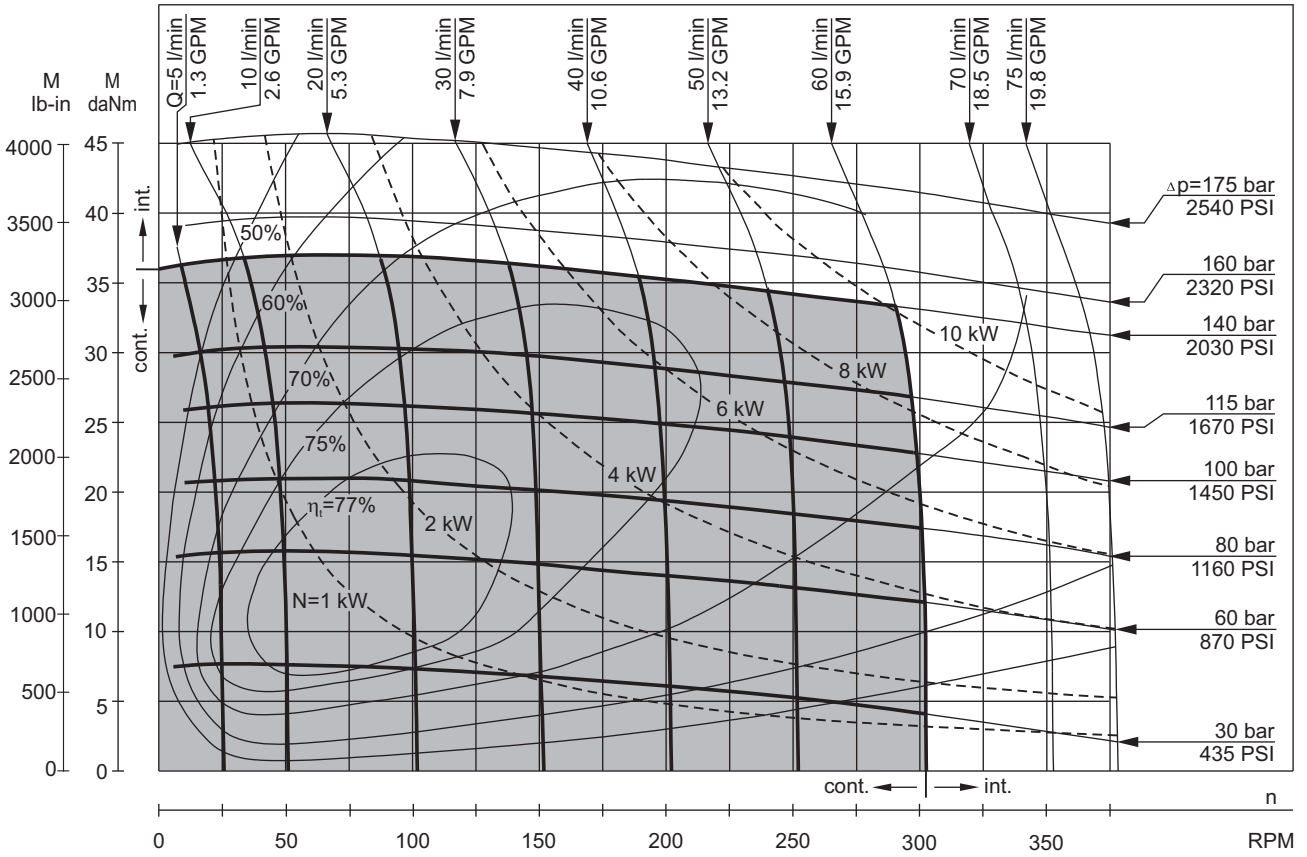

MP 250

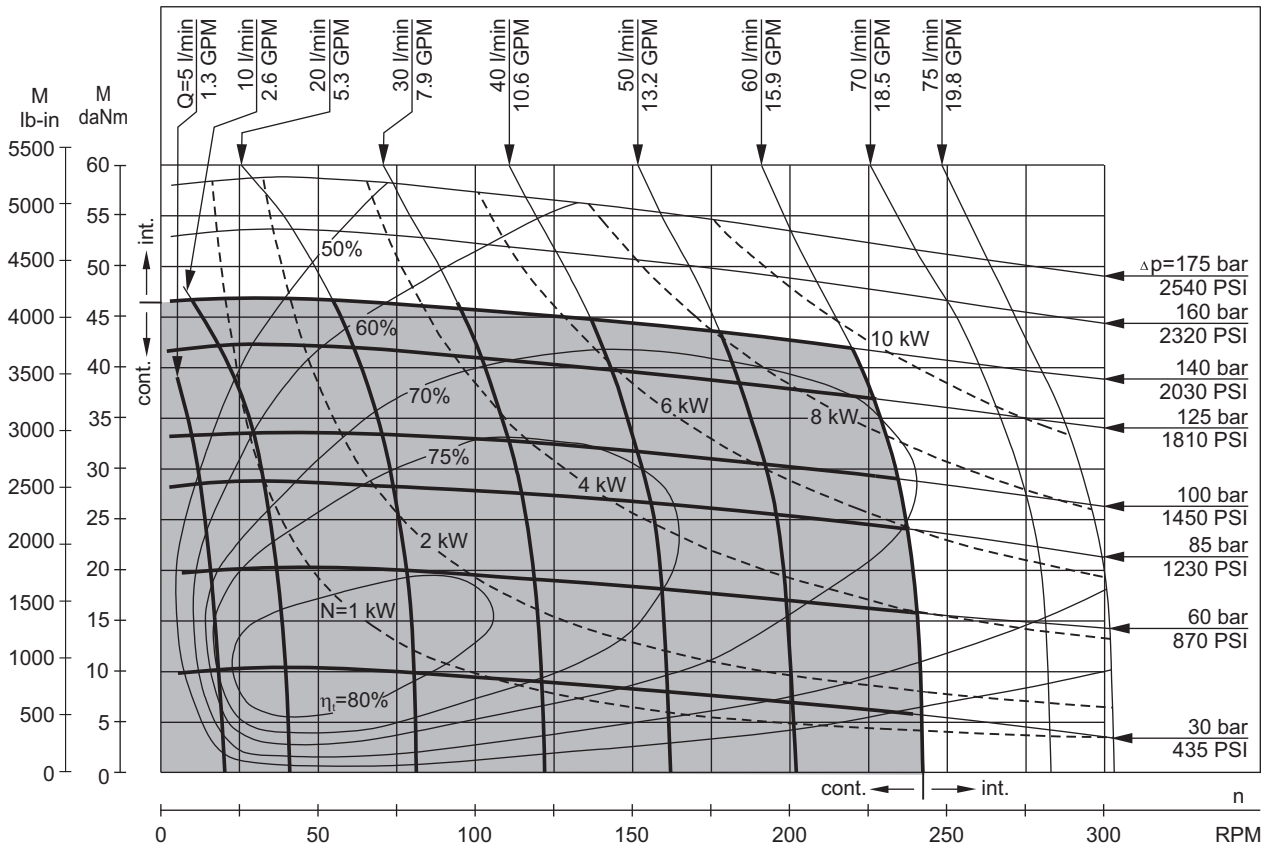

The function diagrams data is for average performance of randomly selected motors at back pressure 5±10 bar [72.5 PSI±145 PSI] and oil with viscosity of 32 mm²/s [150 SUS] at 50°C [122°F].

FUNCTION DIAGRAMS

MP 315

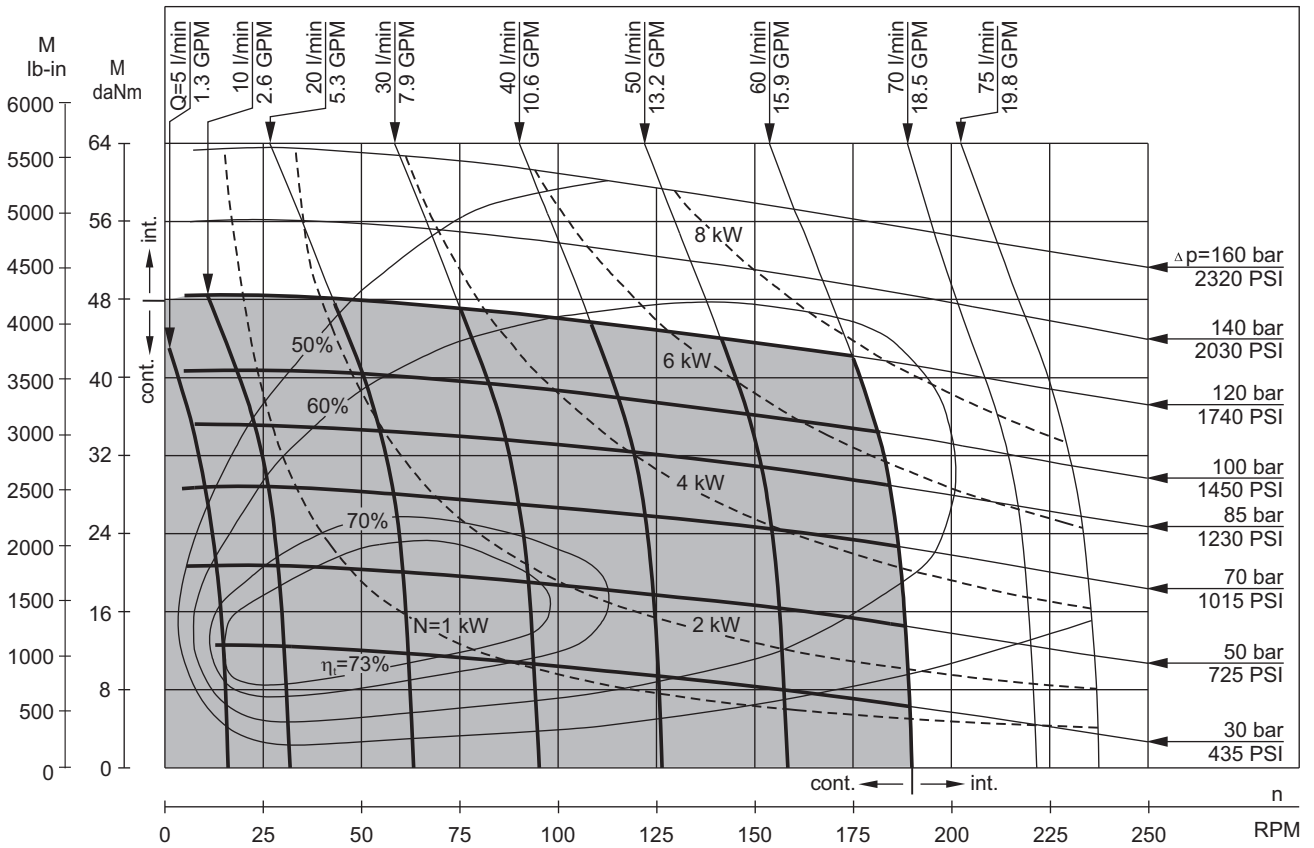

MP 400

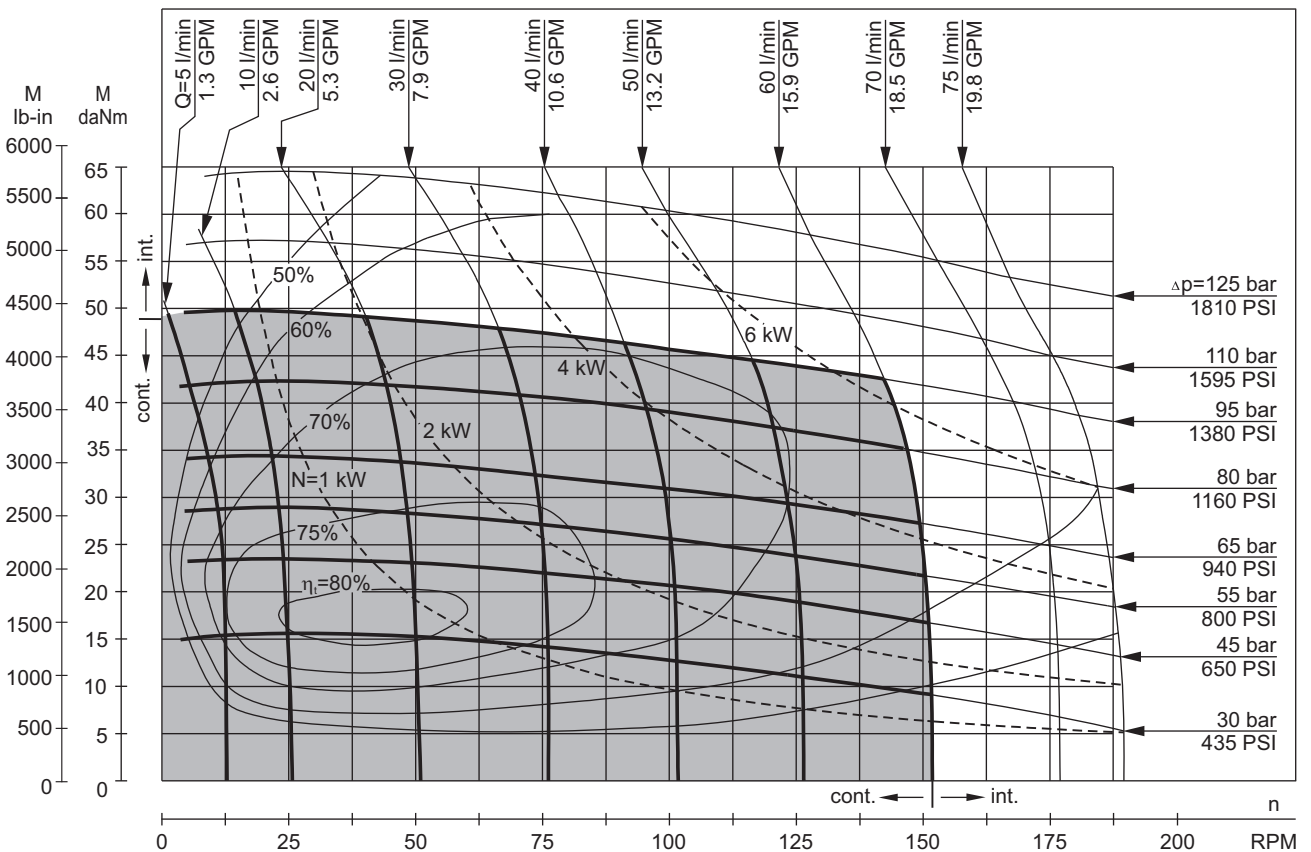

The function diagrams data is for average performance of randomly selected motors at back pressure 5±10 bar [72.5 PSI±145 PSI] and oil with viscosity of 32 mm²/s [150 SUS] at 50°C [122°F].

FUNCTION DIAGRAMS

MP 500

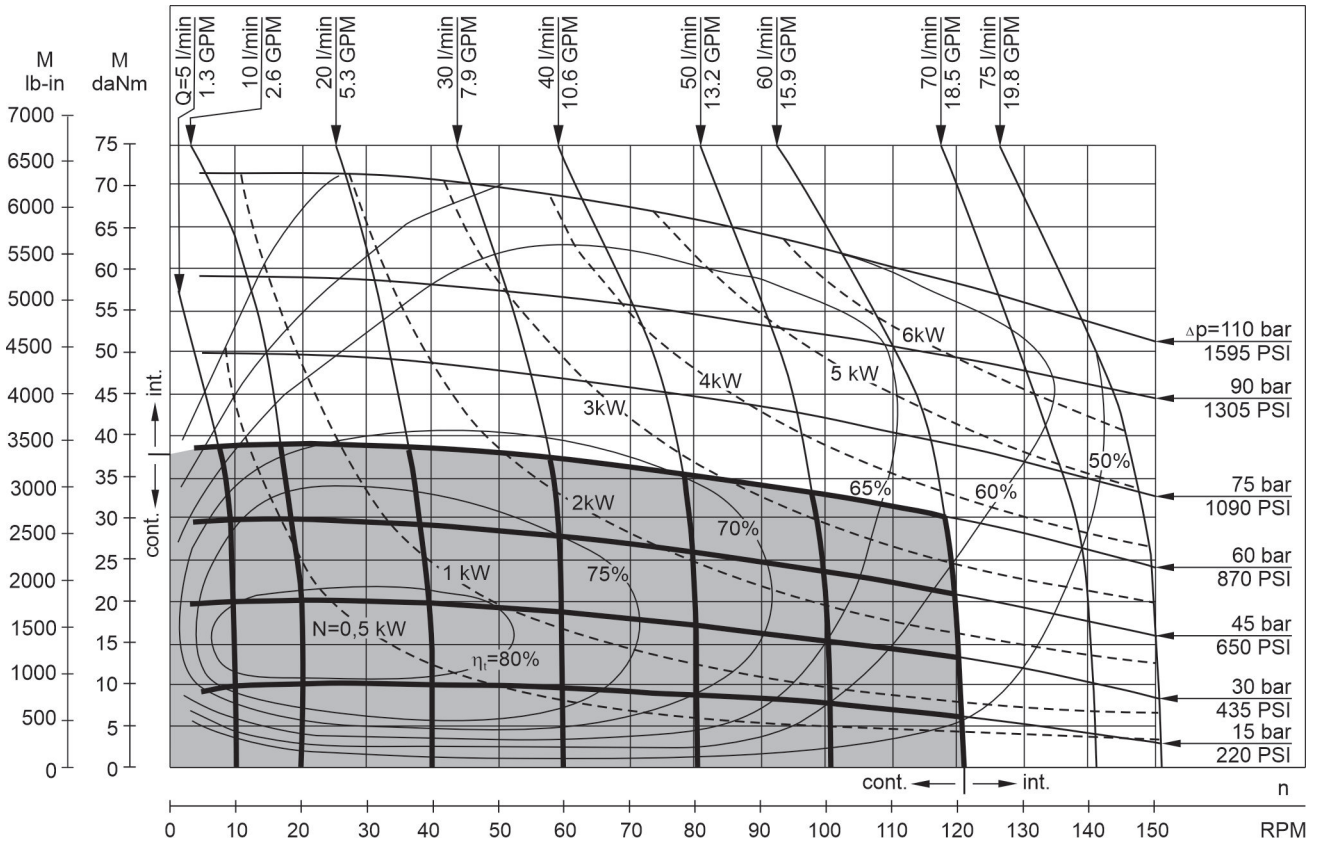

MP 630

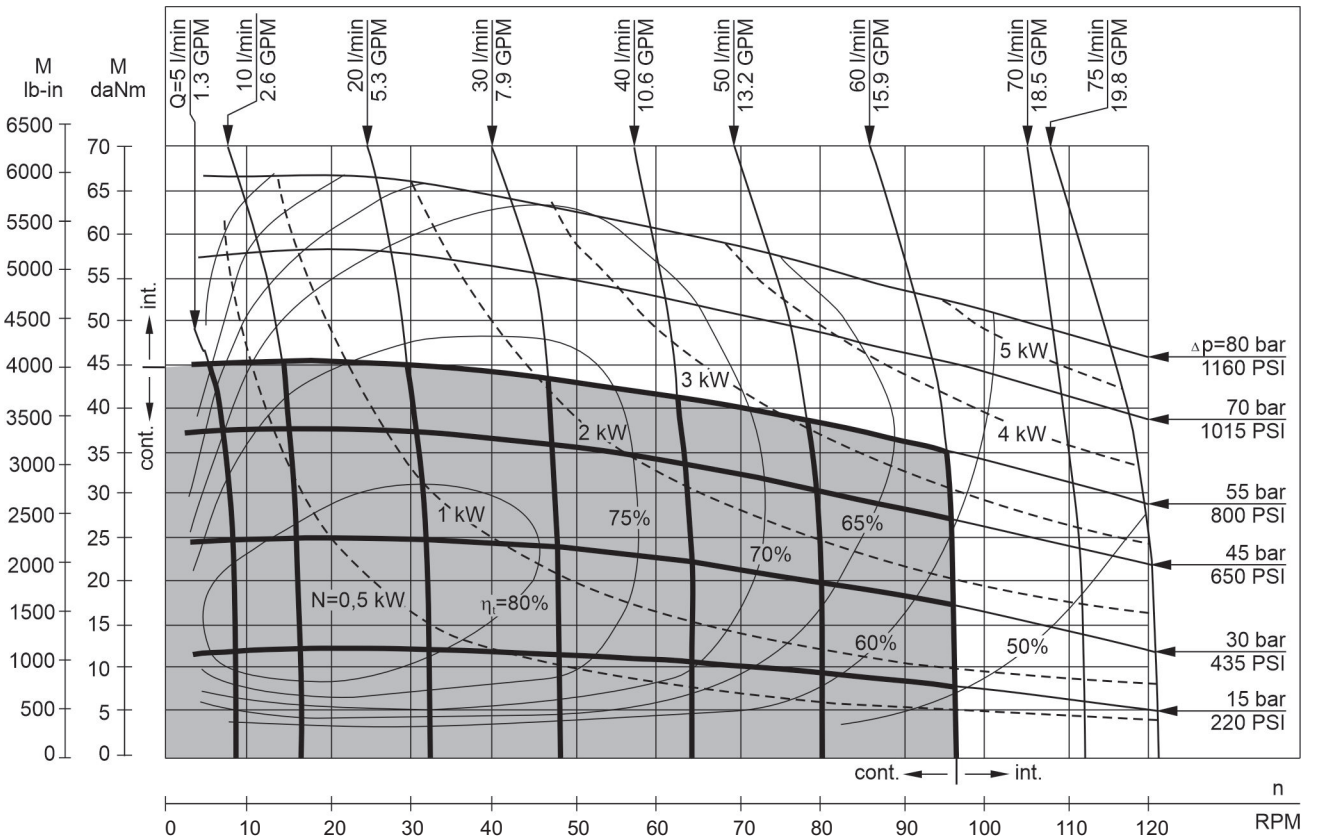

The function diagrams data is for average performance of randomly selected motors at back pressure = 5±10 bar [72.5 PSI±145 PSI] and oil with viscosity of 32 mm²/s [150 SUS] at 50°C [122°F].

DIMENSIONS and MOUNTING DATA

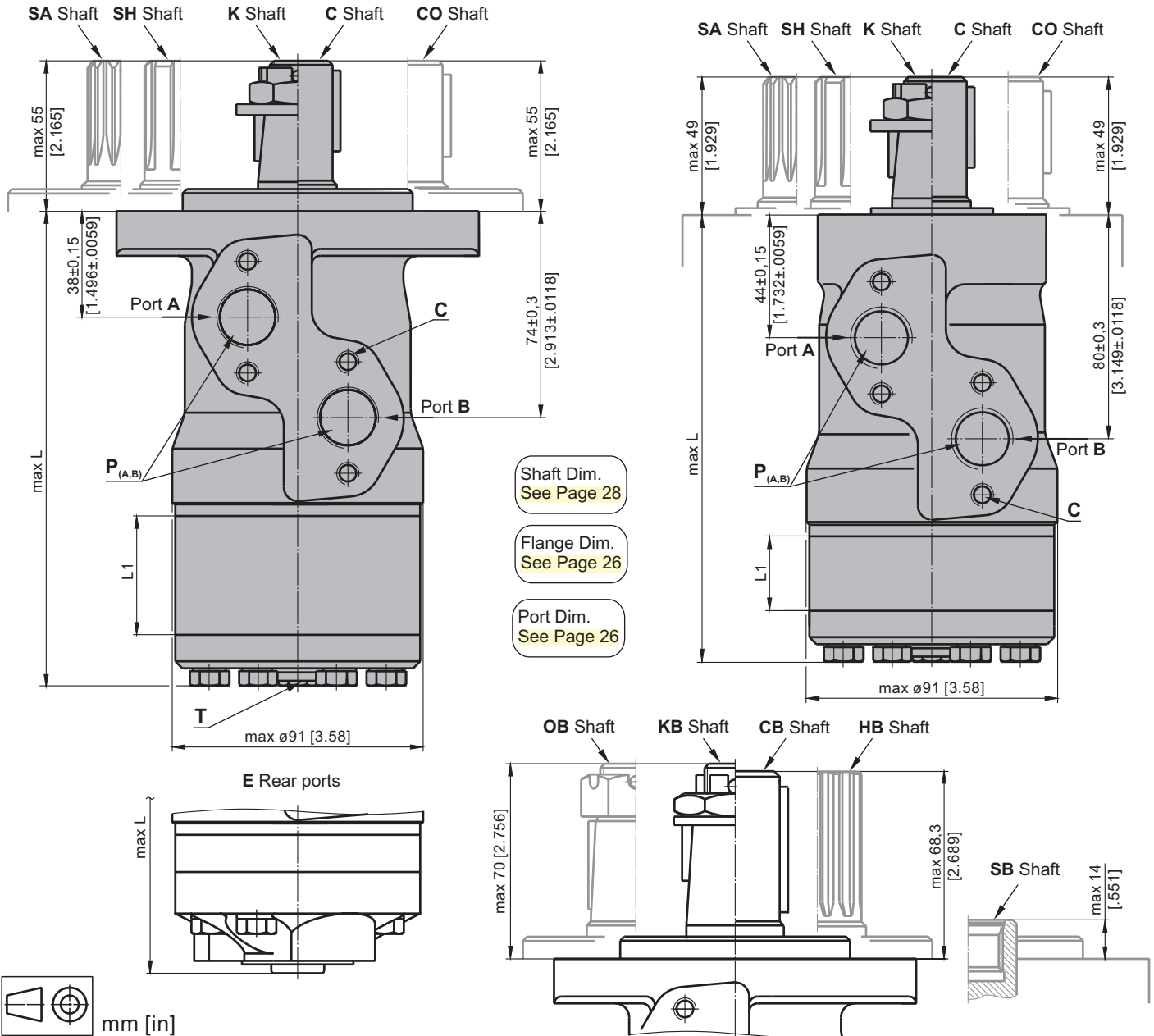

- C** : 4xM8 - 13 mm [.51 in] depth
- P_(A,B)** : 2xG1/2 or 2xM22x1,5 - 15 mm [.59 in] depth
- T** : G1/4 or M14x1,5 - 12 mm [.47 in] depth (plugged)

- Standard Rotation**
Viewed from Shaft End
Port A Pressurized - **CW**
Port B Pressurized - **CCW**
- Reverse Rotation**
Viewed from Shaft End
Port A Pressurized - **CCW**
Port B Pressurized - **CW**

Type	L, mm [in]	Type	L, mm [in]	Type	L, mm [in]	Type	L, mm [in]	L1, mm [in]
MP(F) 25	134,0 [5.28]	MPQ 25	140,5 [5.53]	MP(F)E 25	150,0 [5.91]	MPQE 25	156,5 [6.16]	5,20 [.21]
MP(F) 32	135,0 [5.31]	MPQ 32	141,5 [5.57]	MP(F)E 32	151,5 [5.96]	MPQE 32	157,5 [6.20]	6,30 [.25]
MP(F) 40	136,5 [5.37]	MPQ 40	142,5 [5.61]	MP(F)E 40	152,5 [6.00]	MPQE 40	158,5 [6.24]	7,40 [.29]
MP(F) 50	135,5 [5.33]	MPQ 50	142,0 [5.59]	MP(F)E 50	151,5 [5.96]	MPQE 50	158,0 [6.22]	6,67 [.26]
MP(F) 63	137,0 [5.39]	MPQ 63	143,5 [5.65]	MP(F)E 63	148,5 [5.85]	MPQE 63	154,5 [6.08]	8,40 [.33]
MP(F) 80	139,5 [5.49]	MPQ 80	146,0 [5.75]	MP(F)E 80	155,5 [6.12]	MPQE 80	162,0 [6.38]	10,67 [.42]
MP(F) 100	142,0 [5.59]	MPQ 100	148,5 [5.85]	MP(F)E 100	158,5 [6.24]	MPQE 100	164,5 [6.48]	13,33 [.52]
MP(F) 125	145,5 [5.73]	MPQ 125	152,0 [5.98]	MP(F)E 125	161,5 [6.36]	MPQE 125	168,0 [6.61]	16,67 [.66]
MP(F) 160	150,0 [5.91]	MPQ 160	156,5 [6.16]	MP(F)E 160	166,5 [6.56]	MPQE 160	172,5 [6.79]	21,33 [.84]
MP(F) 200	155,5 [6.12]	MPQ 200	162,0 [6.38]	MP(F)E 200	171,5 [6.75]	MPQE 200	178,0 [7.01]	26,67 [1.05]
MP(F) 250	162,0 [6.38]	MPQ 250	168,5 [6.63]	MP(F)E 250	178,5 [7.03]	MPQE 250	184,5 [7.26]	33,33 [1.31]
MP(F) 315	171,5 [6.75]	MPQ 315	178,0 [7.01]	MP(F)E 315	187,5 [7.38]	MPQE 315	194,0 [7.64]	42,67 [1.68]
MP(F) 400	182,0 [7.17]	MPQ 400	188,5 [7.42]	MP(F)E 400	198,5 [7.81]	MPQE 400	204,5 [8.05]	53,33 [2.10]
MP(F) 500	195,5 [7.70]	MPQ 500	202,0 [7.95]	MP(F)E 500	211,5 [8.33]	MPQE 500	218,0 [8.58]	66,63 [2.62]
MP(F) 630	213,0 [8.39]	MPQ 630	219,0 [8.62]	MP(F)E 630	229,0 [9.02]	MPQE 630	235,0 [9.25]	84,00 [3.31]

MOUNTING

Oval mount (2 holes)

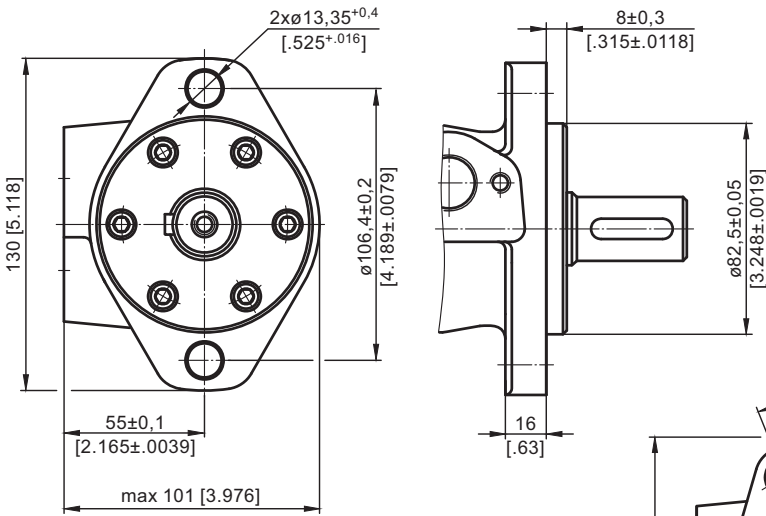

F - Oval mount (four holes)

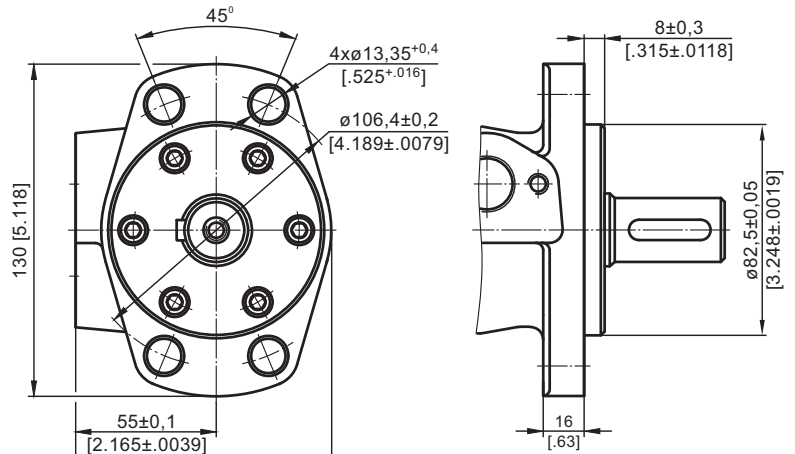

Q - Square mount (four bolts)

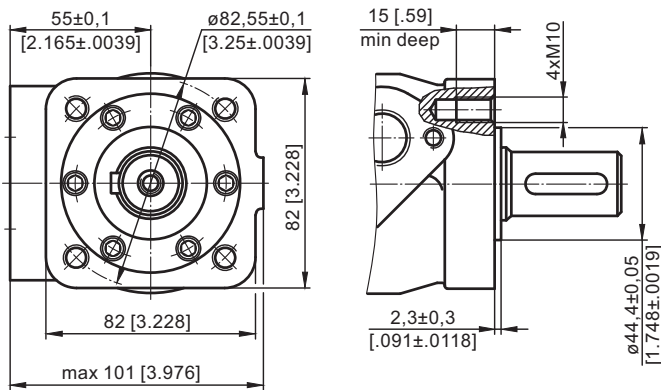

Side Ports

PORTS

E Rear Ports

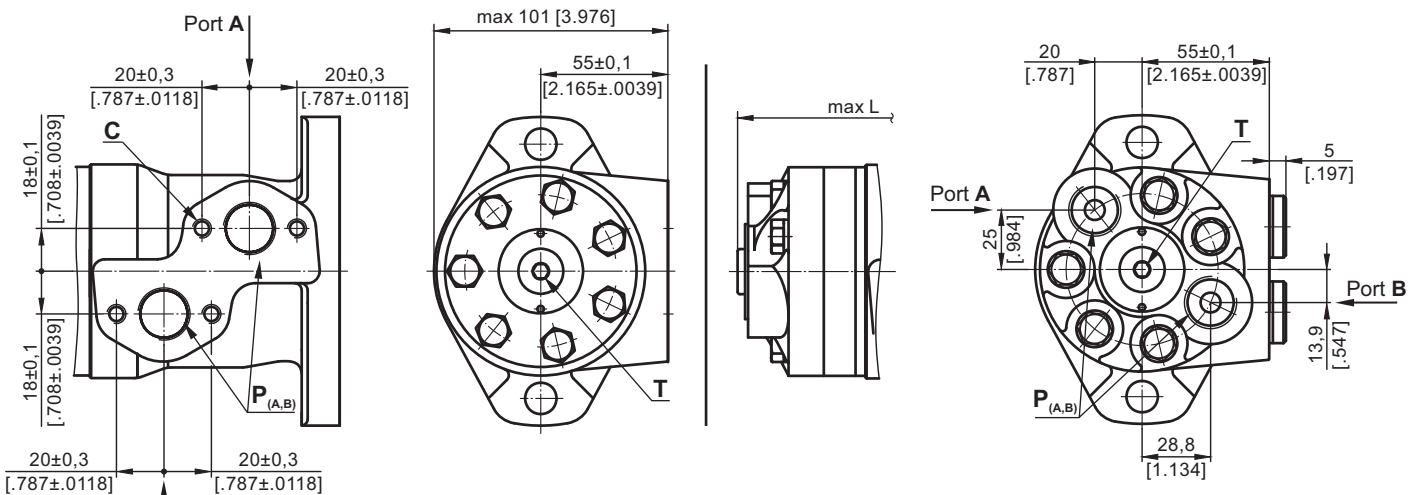

- C** : 4xM8 - 13 mm [0.51 in] depth
- P_(A,B)** : 2xG1/2 or 2xM22x1,5 - 15 mm [0.59 in] depth
- T** : G1/4 or M14x1,5 - 12 mm [0.47 in] depth (plugged)

Standard Rotation

Viewed from Shaft End
 Port A Pressurized - CW
 Port B Pressurized - CCW

Reverse Rotation

Viewed from Shaft End
 Port A Pressurized - CCW
 Port B Pressurized - CW

DIMENSIONS and MOUNTING DATA - MPW

W - Wheel mount

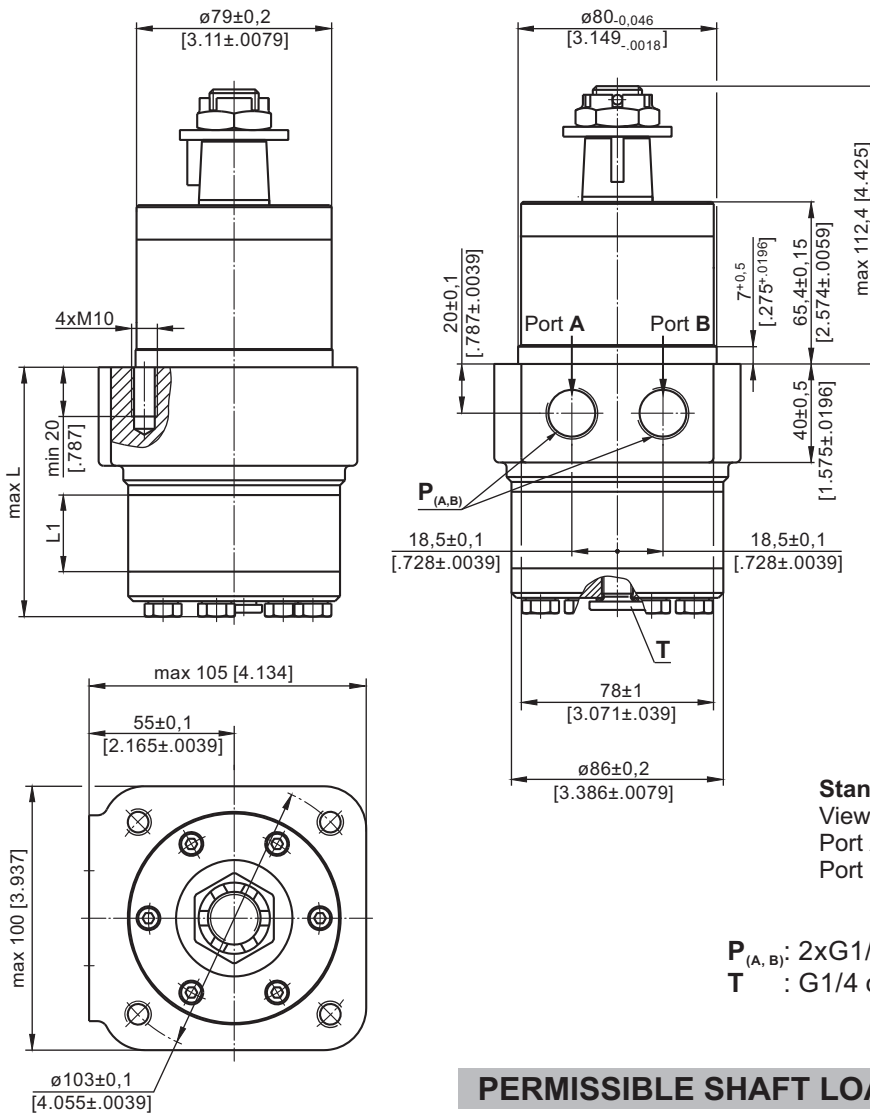

Standard Rotation
Viewed from Shaft End
Port A Pressurized - CW
Port B Pressurized - CCW

Reverse Rotation
Viewed from Shaft End
Port A Pressurized - CCW
Port B Pressurized - CW

P_(A,B) : 2xG1/2 or 2xM22x1,5 - 15 mm [.59 in] depth
T : G1/4 or M14x1,5 - 12 mm [.47 in] depth (plugged)

PERMISSIBLE SHAFT LOADS

MPWN

MPW

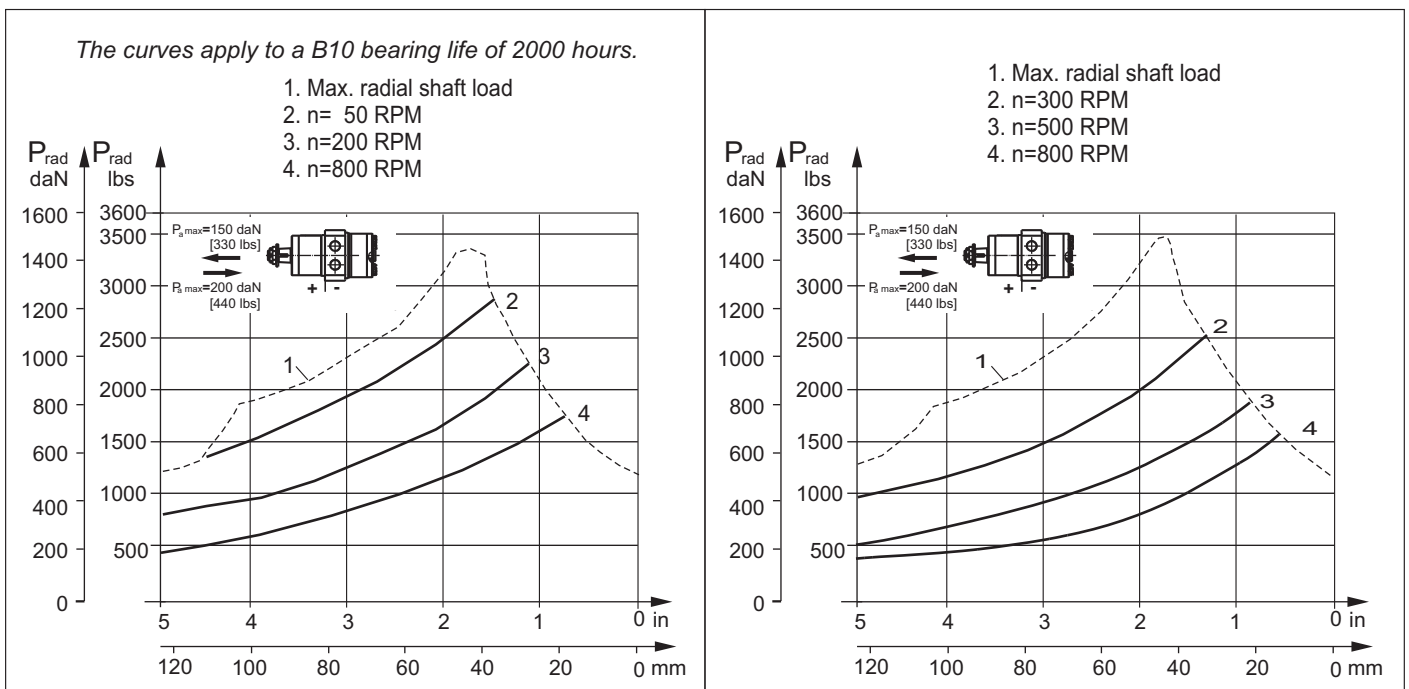

SHAFT EXTENSIONS for MP and MR MOTORS

C - $\varnothing 25$ straight, Parallel key A8x7x32 DIN 6885
Max. Torque 34 daNm [3010 lb-in]

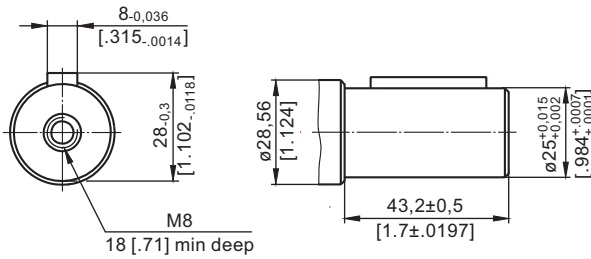

CB - $\varnothing 32$ straight, Parallel key A10x8x45 DIN 6885
Max. Torque 77 daNm [6815 lb-in]

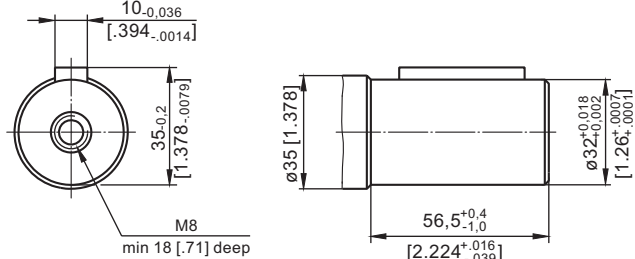

CO - $\varnothing 1$ " straight, Parallel key $\frac{1}{4}$ "x $\frac{1}{4}$ "x $\frac{1}{4}$ " BS46
Max. Torque 34 daNm [3010 lb-in]

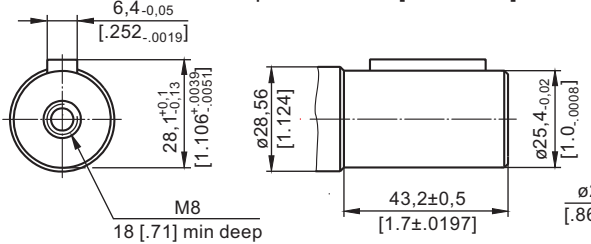

SB - splined, A25x22xH10 DIN 5482
Max. Torque 34 daNm [3010 lb-in]

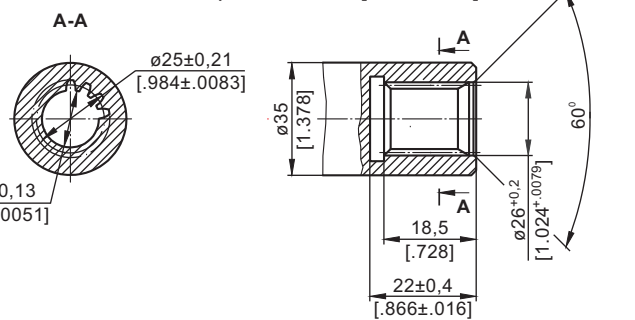

SH - splined, BS 2059 (SAE 6B)
Max. Torque 40 daNm [3540 lb-in]

KB - tapered 1:10, Parallel key B6x6x20 DIN 6885
Max. Torque 77 daNm [6815 lb-in]

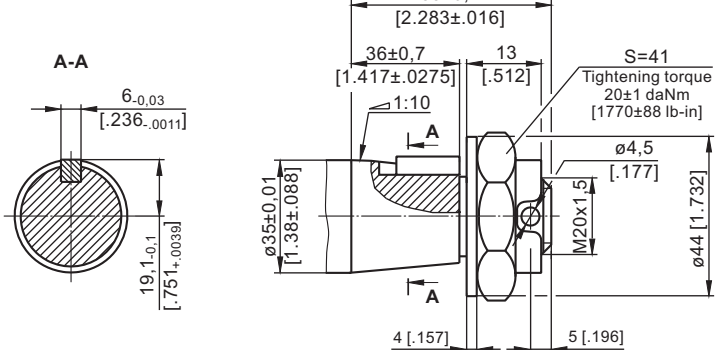
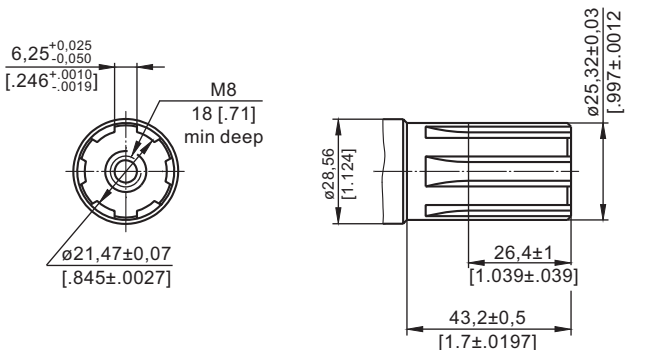

K - tapered 1:10, Parallel key B5x5x14 DIN 6885
Max. Torque 40 daNm [3540 lb-in]

OB - tapered 1:8 SAE J501, Parallel key $\frac{5}{16}$ "x $\frac{5}{16}$ "x $\frac{1}{4}$ " BS46
Max. Torque 77 daNm [6815 lb-in]

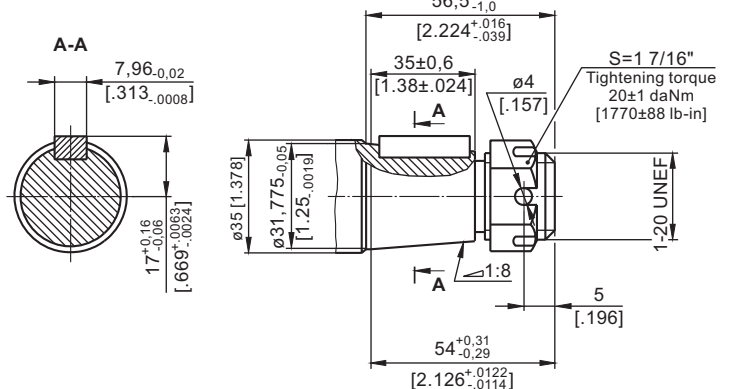
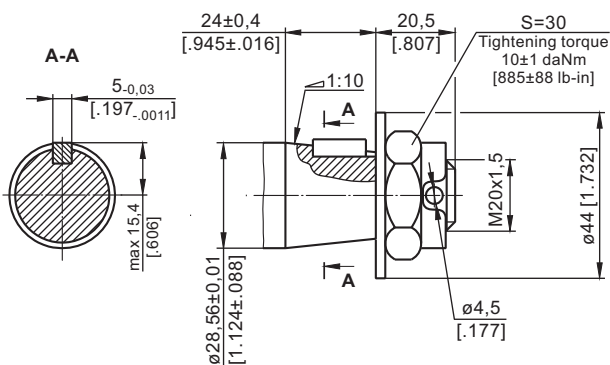

SA - splined, B25x22xH9 DIN 5482
Max. Torque 40 daNm [3540 lb-in]

HB - $\varnothing 1\frac{1}{4}$ " splined 14T, ANSI B92.1-1976 Norm
Max. Torque 77 daNm [6815 lb-in]

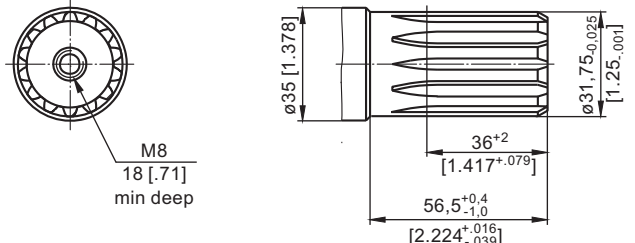
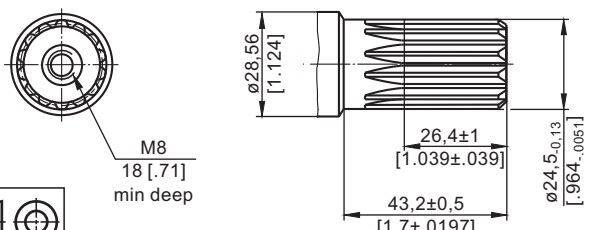

PERMISSIBLE SHAFT LOADS for MP and MR MOTORS

The permissible radial shaft load P_{rad} depends on the speed n , RPM, distance L from the point of load to the mounting flange and shaft version.

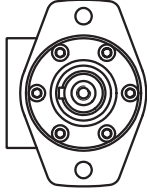
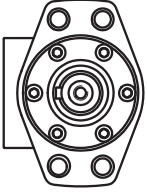
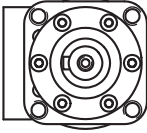
Mounting Flange			
Shaft Version	cylindrical - C, CO tapered - K, splined - SH	splined - HB cylindrical - CB	cylindrical - C, CO
Radial Shaft Load P_{rad} , in mm	$\frac{800}{n} \times \frac{25000}{95+L}$, daN*	$\frac{800}{n} \times \frac{18750}{95+L}$, daN*	$\frac{800}{n} \times \frac{25000}{101+L}$, daN*
Radial Shaft Load P_{rad} , in inch	$\frac{800}{RPM} \times \frac{2215}{3.74+L}$, lbs*	$\frac{800}{RPM} \times \frac{1660}{3.74+L}$, lbs*	$\frac{800}{RPM} \times \frac{2215}{3.98+L}$, lbs*

* $n < 200$ RPM; max P_{rad} =800 daN [1800 lbs]
 $n \geq 200$ RPM; $L < 55$ mm [2.2 in]

MP and MR

Radial Shaft Load P_{rad} for C, CO Shaft Extensions by $L=30$ mm [1.18 in] (24 mm [.94 in])

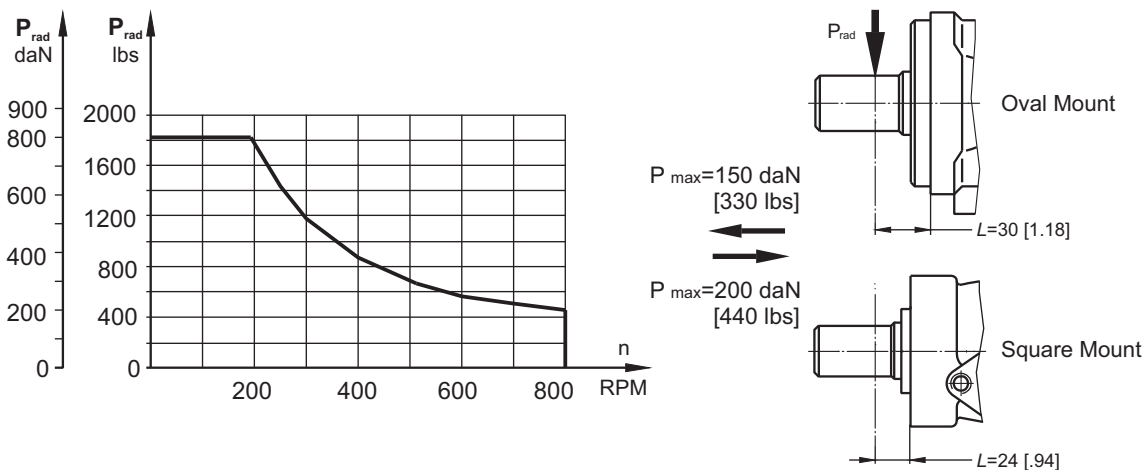

MPN and MRN

The curves apply to a B10 bearing life of 2000 hours.

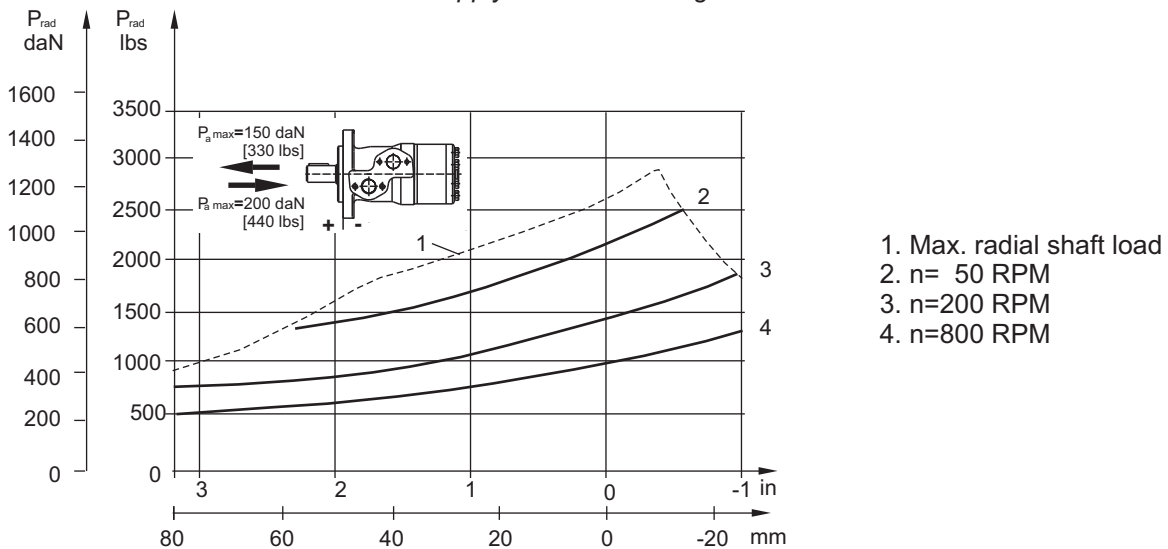

**MAX. PERMISSIBLE SHAFT SEAL PRESSURE
for MP and MR MOTORS**

**MP/MR...U1 motors with high pressure seal
and without drain connection:**

The shaft seal pressure equals the average
of input pressure and return pressure.

$$P_{\text{seal}} = \frac{P_{\text{input}} + P_{\text{return}}}{2}$$

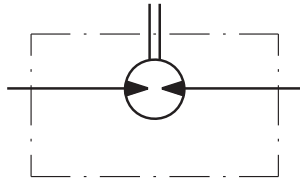

**MP/MR...U motors with high pressure seal
and drain connection:**

The shaft seal pressure equals the pressure
in the drain line.

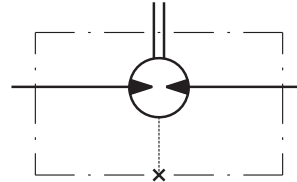

**MP/MR...1 motors with low pressure seal
or standard shaft seal
and without drain connection:**

The shaft seal pressure never exceeds
the pressure in the return line.

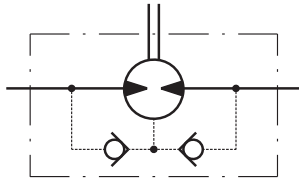

**MP/MR... motors with low pressure seal
or standard shaft seal
and with drain connection:**

The shaft seal pressure equals the pressure
in the drain line.

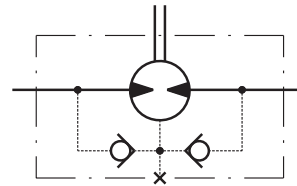

**Max. return pressure without drain line
or max. pressure in the drain line**

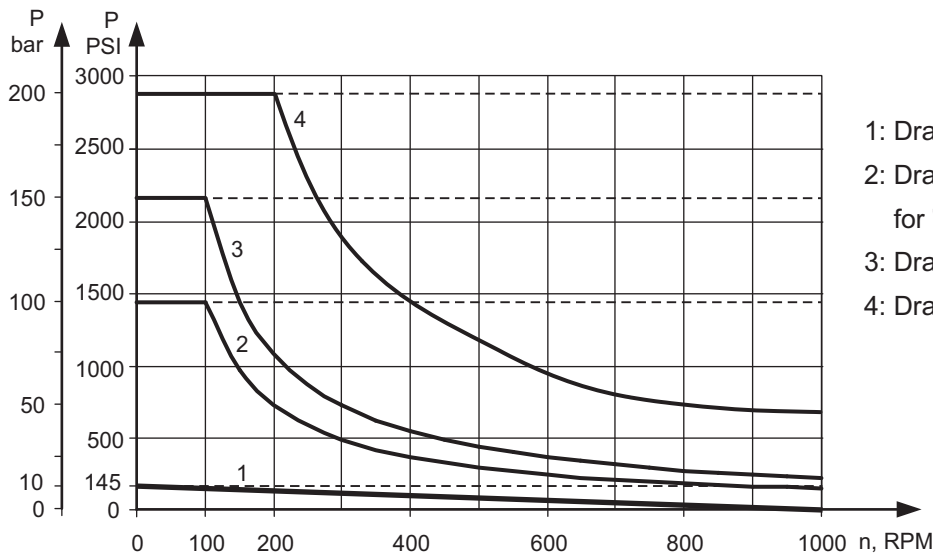

- 1: Drawing for Low Pressure Seal
- 2: Drawing for Standard Shaft Seal
for "...B" shafts
- 3: Drawing for Standard Shaft Seal ("D" Seal)
- 4: Drawing for High Pressure Seal ("U" Seal)

— - continuous operations
- - - - - intermittent operations

ORDER CODE

	1	2	3	4	5	6	7	8	9	10
M P										

Pos.1 - Mounting Flange

- omit - Oval mount, two holes
- F** - Oval mount, four holes
- Q** - Square mount, four bolts
- W** - Wheel mount

Pos.2 - Option (needle bearings)

- omit - none
- N** - with needle bearings

Pos.3 - Port type

- omit - Side ports
- E** - Rear ports

Pos.4 - Displacement code

- 25*** - 25,0 cm³/rev [1.52 in³/rev]
- 32*** - 32,0 cm³/rev [1.95 in³/rev]
- 40*** - 40,0 cm³/rev [2.44 in³/rev]
- 50** - 49,5 cm³/rev [3.02 in³/rev]
- 63**** - 62,3 cm³/rev [3.80 in³/rev]
- 80** - 79,2 cm³/rev [4.83 in³/rev]
- 100** - 99,0 cm³/rev [6.04 in³/rev]
- 125** - 123,8 cm³/rev [7.55 in³/rev]
- 160** - 158,4 cm³/rev [9.66 in³/rev]
- 200** - 198,0 cm³/rev [12.10 in³/rev]
- 250** - 247,5 cm³/rev [15.10 in³/rev]
- 315** - 316,8 cm³/rev [19.30 in³/rev]
- 400** - 396,0 cm³/rev [24.16 in³/rev]
- 500** - 495,0 cm³/rev [30.20 in³/rev]
- 630** - 623,6 cm³/rev [38.05 in³/rev]

Pos. 5 - Shaft Extensions* (see page 28)**

- C** - ø25 straight, Parallel key A8x7x32 DIN6885
- VC** - ø25 straight, Parallel key A8x7x32 DIN6885 with corrosion resistant protection
- CO** - ø1" straight, Parallel key ¼"x¼"x1¼" BS46
- VCO** - ø1" straight, Parallel key ¼"x¼"x1¼" BS46 with corrosion resistant protection
- SH** - ø25,32 splined BS 2059 (SAE 6B)
- VSH** - ø25,32 splined BS 2059 (SAE 6B) with corrosion resistant protection
- K** - ø28,56 tapered 1:10, Parallel key B5x5x14 DIN6885
- SA** - ø24,5 splined B 25x22 DIN 5482
- VSA** - ø24,5 splined B 25x22 DIN 5482 with corrosion resistant protection
- CB** - ø32 straight, Parallel key A10x8x45 DIN6885
- KB** - ø35 tapered 1:10, Parallel key B6x6x20 DIN6885
- SB** - splined A 25x22 DIN 5482
- OB** - ø1¼" tapered 1:8, Parallel key 5/16"x5/16"x1¼" BS46
- HB** - ø1¼" splined 14T ANSI B92.1 - 1976

Pos. 6 - Shaft Seal Version (see page 30)

- omit - Low pressure shaft seal or Standard shaft seal for "...B" shaft
- D** - 150 bar pressure seal /recommended for medium pressure and high speed and high radial load/
- U** - 200 bar pressure seal /recommended for high pressure and low speed of rotation and medium radial load/ (without check valves)

Pos. 7 - Drain Port

- omit - with drain port
- 1** - without drain port

Pos. 8 - Ports

- omit - BSPP (ISO 228)
- M** - Metric (ISO 262)

Pos. 9 - Additional Options (see page 125)

Pos.10 - Design Series

- omit - Factory specified

NOTES: * Not with Low Pressure Seal.
 ** 63 displacement code is not for MPW!
 *** The permissible output torque for shafts must not be exceeded.

The following combinations are not allowed: - **Q** flange with "...B" shafts;
 - **W** flange with "...B" shafts or **E** rear ports;
 - **N** option with "...B" shafts, Low Pressure Seal or **U** option;
 - "...B" shafts with **D** and **U** shaft seals.

Displacement codes 25, 32, 40, 50 and 63 are not allowed with **CB, KB, OB, HB** shafts!

The hydraulic motors are mangano-phosphatized as standard.

HYDRAULIC MOTORS MR



APPLICATION

- » Conveyors
- » Feeding mechanism of robots and manipulators
- » Metal working machines
- » Textile machines
- » Agricultural machines
- » Food industries
- » Grass cutting machinery etc.

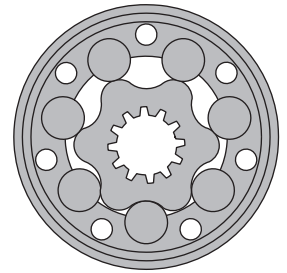

CONTENTS

Specification data	33÷34
Function diagrams	35÷39
Dimensions and mounting	40÷41
Shaft extensions	28
Permissible shaft loads	29
Permissible shaft seal pressure	30
Order code	42

OPTIONS

- » Model - Spool valve, roll-gerotor
- » Flange mount
- » Motor with needle bearing
- » Side and rear ports
- » Shafts - straight, splined and tapered
- » Shaft seal for high and low pressure
- » Metric and BSPP ports
- » Speed sensing
- » Other special features

GENERAL

Max. Displacement,	cm ³ /rev [in ³ /rev]	397 [24.4]
Max. Speed,	[RPM]	970
Max. Torque,	daNm [lb-in]	cont.: 61 [5400] int.: 69 [6100]
Max. Output,	kW [HP]	15 [20.1]
Max. Pressure Drop,	bar [PSI]	cont.: 175 [2540] int.: 200 [2900]
Max. Oil Flow,	lpm [GPM]	75 [20]
Min. Speed,	[RPM]	10
Pressure fluid		Mineral based- HLP (DIN 51524) or HM (ISO 6743/4)
Temperature range,	°C [°F]	-40÷140 [-40÷284]
Optimal Viscosity range,	mm ² /s [SUS]	20÷75 [98÷347]
Filtration		ISO code: 18/16/13 According to ISO 4406-1999

Oil flow in drain line

Pressure drop bar [PSI]	Viscosity mm ² /s [SUS]	Oil flow in drain line lpm [GPM]
100 [1450]	20 [98]	2,5 [.660]
	35 [164]	1,8 [.476]
140 [2030]	20 [98]	3,5 [.925]
	35 [164]	2,8 [.740]

Pressure Losses

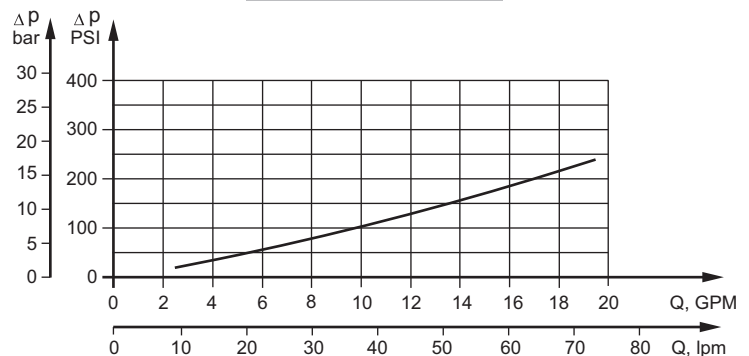

SPECIFICATION DATA

Specification Data for MR... motors with **C, CO, SH, K** and **SA** shafts.
($\varnothing 28,56$ sealing diameter)

Type		MR 50	MR 80	MR 100	MR 125	MR 160	MR 200	MR 250	MR 315	MR 400
Displacement, cm³/rev [in³/rev]		51,5 [3.14]	80,3 [4.90]	99,8 [6.09]	125,7 [7.67]	159,6 [9.74]	199,8 [12.19]	250,1 [15.26]	315,7 [19.26]	397 [24.4]
	Max. Speed, [RPM]									
	Cont.	775	750	600	475	375	300	240	190	150
	Int.*	970	940	750	600	470	375	300	240	190
Max. Torque, daNm [lb-in]	Cont.	10 [900]	20 [1770]	24 [2125]	30 [2655]	39 [3450]	38,5 [3410]	39 [3450]	36 [3185]	38 [3360]
	Int.*	13 [1150]	22 [1950]	28 [2480]	34 [3010]	43 [3805]	46 [4070]	47 [4160]	47 [4160]	47 [4160]
	Peak**	17 [1505]	27 [2390]	32 [2830]	37 [3275]	46 [4070]	56 [4960]	60 [5310]	61 [5400]	61 [5400]
Max. Output, kW [HP]	Cont.	7 [9.4]	12,5 [16.8]	13 [17.4]	12,5 [16.8]	11,5 [15.4]	9 [12.1]	8 [10.7]	5 [6.7]	4,8 [6.4]
	Int.*	8,5 [11.4]	15 [20.1]	15 [20.1]	14,5 [19.4]	14 [18.8]	12 [16.1]	9,5 [12.7]	8 [10.7]	6,8 [9.1]
Max. Pressure Drop, bar [PSI]	Cont.	140 [2030]	175 [2540]	175 [2540]	175 [2540]	175 [2540]	140 [2030]	110 [1600]	85 [1230]	65 [940]
	Int.*	175 [2540]	200 [2900]	200 [2900]	200 [2900]	200 [2900]	175 [2540]	140 [2030]	115 [1670]	90 [1300]
	Peak**	225 [3260]	225 [3260]	225 [3260]	225 [3260]	225 [3260]	225 [3260]	200 [2900]	150 [2175]	115 [1670]
Max. Oil Flow, lpm [GPM]	Cont.	60 [15.8]	60 [15.8]	60 [15.8]	60 [15.8]	60 [15.8]	60 [15.8]	60 [15.8]	60 [15.8]	60 [15.8]
	Int.*	75 [19.8]	75 [19.8]	75 [19.8]	75 [19.8]	75 [19.8]	75 [19.8]	75 [19.8]	75 [19.8]	75 [19.8]
Max. Inlet Pressure, bar [PSI]	Cont.	175 [2540]	175 [2540]	175 [2540]	175 [2540]	175 [2540]	175 [2540]	175 [2540]	175 [2540]	175 [2540]
	Int.*	200 [2900]	200 [2900]	200 [2900]	200 [2900]	200 [2900]	200 [2900]	200 [2900]	200 [2900]	200 [2900]
	Peak**	225 [3260]	225 [3260]	225 [3260]	225 [3260]	225 [3260]	225 [3260]	225 [3260]	225 [3260]	225 [3260]
Max. Starting Pressure with Drain Line, bar [PSI]	Cont.	175 [2540]	175 [2540]	175 [2540]	175 [2540]	175 [2540]	175 [2540]	175 [2540]	175 [2540]	175 [2540]
	Int.*	200 [2900]	200 [2900]	200 [2900]	200 [2900]	200 [2900]	200 [2900]	200 [2900]	200 [2900]	200 [2900]
	Peak**	225 [3260]	225 [3260]	225 [3260]	225 [3260]	225 [3260]	225 [3260]	225 [3260]	225 [3260]	225 [3260]
Max. Starting Pressure with Unloaded Shaft, bar [PSI]		10 [145]	10 [145]	10 [145]	9 [130]	7 [102]	5 [73]	4 [58]	3 [44]	3 [44]
Min. Starting Torque, daNm [lb-in]	At max.press. drop Cont.	8 [710]	15 [1310]	20 [1770]	25 [2215]	32 [2830]	33 [2920]	31 [2740]	31,5 [2875]	31,5 [2875]
	At max.press. drop Int.*	10 [885]	17 [1505]	23 [2035]	28 [2480]	37 [3275]	40 [3540]	48 [4250]	58 [5220]	50 [4425]
Min. Speed***, [RPM]		10	10	10	10	10	10	10	10	10
Weight, kg [lb]	MR(F)	6,8 [15]	6,9 [15.2]	7,2 [15.9]	7,3 [16.1]	7,5 [15.2]	8 [17.6]	8,4 [18.5]	9,1 [20]	9,8 [21.6]
	For rear ports: +0,650 [1.433] MRQ(N)	6,2 [13.7]	6,3 [13.9]	6,6 [14.6]	6,8 [15]	7,2 [14.7]	7,6 [15.4]	7,8 [17.2]	8,6 [19]	9,3 [20.5]

* Intermittent operation: the permissible values may occur for max. 10% of every minute.

** Peak load: the permissible values may occur for max. 1% of every minute.

*** For speeds lower than given, consult factory or your regional manager.

- Intermittent speed and intermittent pressure must not occur simultaneously.
- Recommended filtration is per ISO cleanliness code 20/16. A nominal filtration of 25 micron or better.
- Recommend using a premium quality, anti-wear type mineral based hydraulic oil HLP(DIN51524) or HM (ISO 6743/4).
If using synthetic fluids consult the factory for alternative seal materials.
- Recommended minimum oil viscosity 13 mm²/s [70 SUS] at 50°C [122°F].
- Recommended maximum system operating temperature is 82°C [180°F].
- To assure optimum motor life fill with fluid prior to loading and run at moderate load and speed for 10-15 minutes.

SPECIFICATION DATA (continued)

Specification Data for MR... motors with **CB, KB, OB** and **HB** shafts.
(ø35 sealing diameter)

Type		MR 50	MR 80	MR 100	MR 125	MR 160	MR 200	MR 250	MR 315	MR 400
Displacement, cm³/rev [in³/rev]		51,5	80,3	99,8	125,7	159,6	199,8	250,1	315,7	397
		[3.14]	[4.90]	[6.09]	[7.67]	[9.74]	[12.19]	[15.26]	[19.26]	[24.4]
Max. Speed, [RPM]	Cont.	775	750	600	475	375	300	240	190	150
	Int.*	970	940	750	600	470	375	300	240	190
Max. Torque, daNm [lb-in]	Cont.	10 [900]	20 [1770]	24 [2125]	30 [2655]	39 [3450]	45 [4000]	54 [4780]	55 [4870]	61 [5400]
	Int.*	13 [1150]	22 [1950]	28 [2480]	34 [3010]	43 [3805]	50 [4425]	61 [5400]	69 [6110]	69 [6110]
	Peak**	17 [1505]	27 [2390]	32 [2830]	37 [3275]	46 [4070]	56 [4960]	71 [6280]	84 [7435]	87 [7700]
Max. Output, kW [HP]	Cont.	7 [9.5]	12,5 [16.8]	13 [17.4]	12,5 [16.8]	11,5 [15.4]	11 [14.8]	10 [13.4]	9 [12]	7,8 [10.5]
	Int.*	8,5 [11.9]	15 [20.1]	15 [20.1]	14,5 [19.5]	14 [18.8]	13 [17.4]	12 [16.1]	10 [13.4]	10,6 [14.2]
Max. Pressure Drop, bar [PSI]	Cont.	140 [2030]	175 [2540]	175 [2540]	175 [2540]	175 [2540]	175 [2540]	175 [2540]	135 [1960]	110 [1600]
	Int.*	175 [2540]	200 [2900]	200 [2900]	200 [2900]	200 [2900]	200 [2900]	200 [2900]	175 [2540]	140 [2030]
	Peak**	225 [3260]	225 [3260]	225 [3260]	225 [3260]	225 [3260]	225 [3260]	225 [3260]	210 [3045]	175 [2540]
Max. Oil Flow, lpm [GPM]	Cont.	40 [10.5]	60 [15.8]	60 [15.8]	60 [15.8]	60 [15.8]	60 [15.8]	60 [15.8]	60 [15.8]	60 [15.8]
	Int.*	50 [13.2]	75 [19.8]	75 [19.8]	75 [19.8]	75 [19.8]	75 [19.8]	75 [19.8]	75 [19.8]	75 [19.8]
Max. Inlet Pressure, bar [PSI]	Cont.	175 [2540]	175 [2540]	175 [2540]	175 [2540]	175 [2540]	175 [2540]	175 [2540]	175 [2540]	175 [2540]
	Int.*	200 [2900]	200 [2900]	200 [2900]	200 [2900]	200 [2900]	200 [2900]	200 [2900]	200 [2900]	200 [2900]
	Peak**	225 [3260]	225 [3260]	225 [3260]	225 [3260]	225 [3260]	225 [3260]	225 [3260]	225 [3260]	225 [3260]
Max. Starting Pressure with Drain Line, bar [PSI]	Cont.	175 [2540]	175 [2540]	175 [2540]	175 [2540]	175 [2540]	175 [2540]	175 [2540]	175 [2540]	175 [2540]
	Int.*	200 [2900]	200 [2900]	200 [2900]	200 [2900]	200 [2900]	200 [2900]	200 [2900]	200 [2900]	200 [2900]
	Peak**	225 [3260]	225 [3260]	225 [3260]	225 [3260]	225 [3260]	225 [3260]	225 [3260]	225 [3260]	225 [3260]
Max. Starting Pressure with Unloaded Shaft, bar [PSI]		10 [145]	10 [145]	10 [145]	9 [130]	7 [102]	5 [73]	4 [58]	3 [44]	3 [44]
Min. Starting Torque, daNm [lb-in]	At max.press. drop Cont.	8 [710]	15 [1310]	20 [1770]	25 [2215]	32 [2830]	41 [3630]	50 [4425]	50 [4425]	50 [4425]
	At max.press. drop Int.*	10 [885]	17 [1505]	23 [2035]	28 [2480]	37 [3275]	46 [4070]	55 [4870]	66 [5840]	61 [5400]
Min. Speed***, [RPM]		10	10	10	10	10	10	10	10	10
Weight, kg [lb]		6,9 [15.2]	7,0 [15.4]	7,3 [16.1]	7,4 [16.3]	7,6 [15.4]	8,1 [18.9]	8,5 [18.7]	9,2 [20.3]	9,9 [21.8]
For rear ports: +0,650 [1.433]										

* Intermittent operation: the permissible values may occur for max. 10% of every minute.

** Peak load: the permissible values may occur for max. 1% of every minute.

*** For speeds lower than given, consult factory or your regional manager.

- Intermittent speed and intermittent pressure must not occur simultaneously.
- Recommended filtration is per ISO cleanliness code 20/16. A nominal filtration of 25 micron or better.
- Recommend using a premium quality, anti-wear type mineral based hydraulic oil HLP(DIN51524) or HM (ISO 6743/4).
If using synthetic fluids consult the factory for alternative seal materials.
- Recommended minimum oil viscosity 13 mm²/s [70 SUS] at 50°C [122°F].
- Recommended maximum system operating temperature is 82°C [180°F].
- To assure optimum motor life fill with fluid prior to loading and run at moderate load and speed for 10-15 minutes.

FUNCTION DIAGRAMS

MR 50

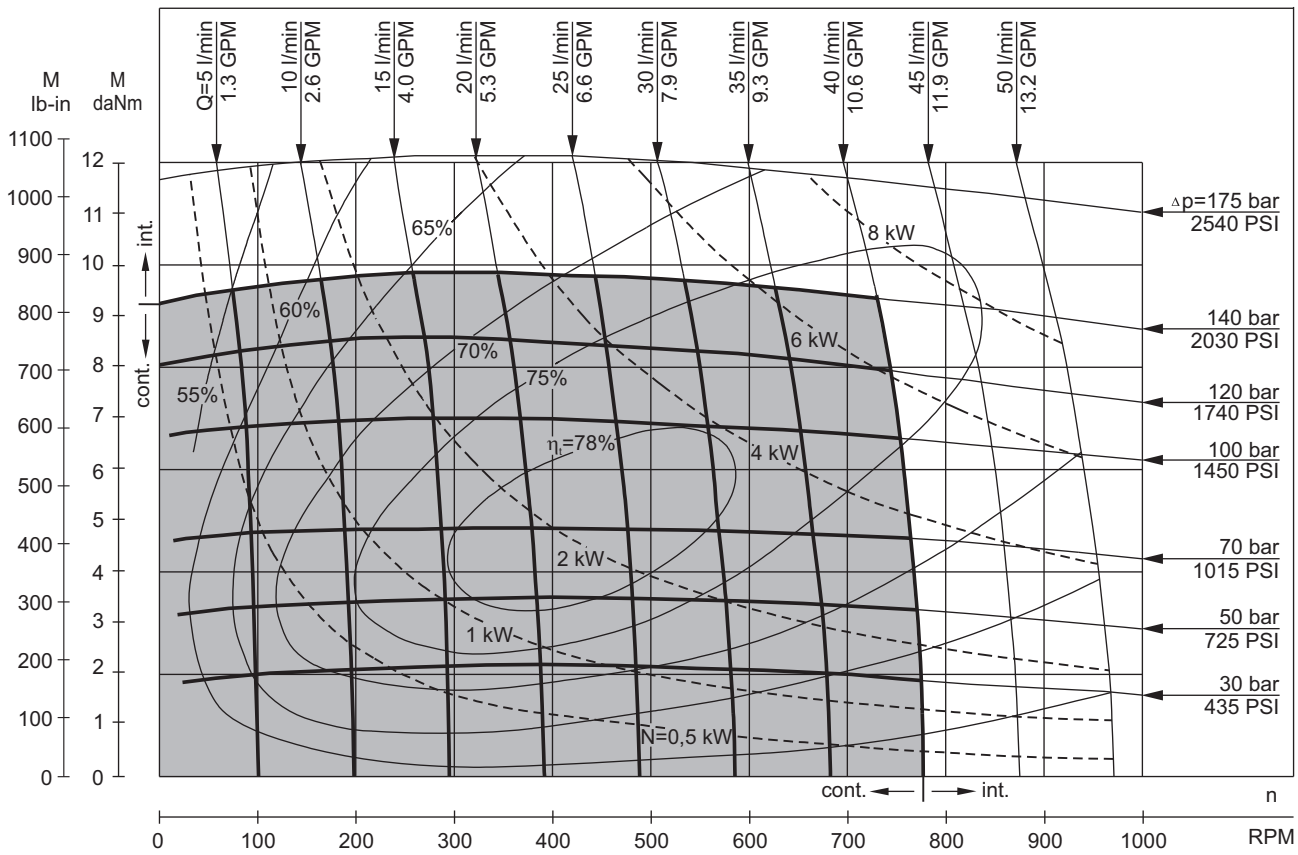

MR 80

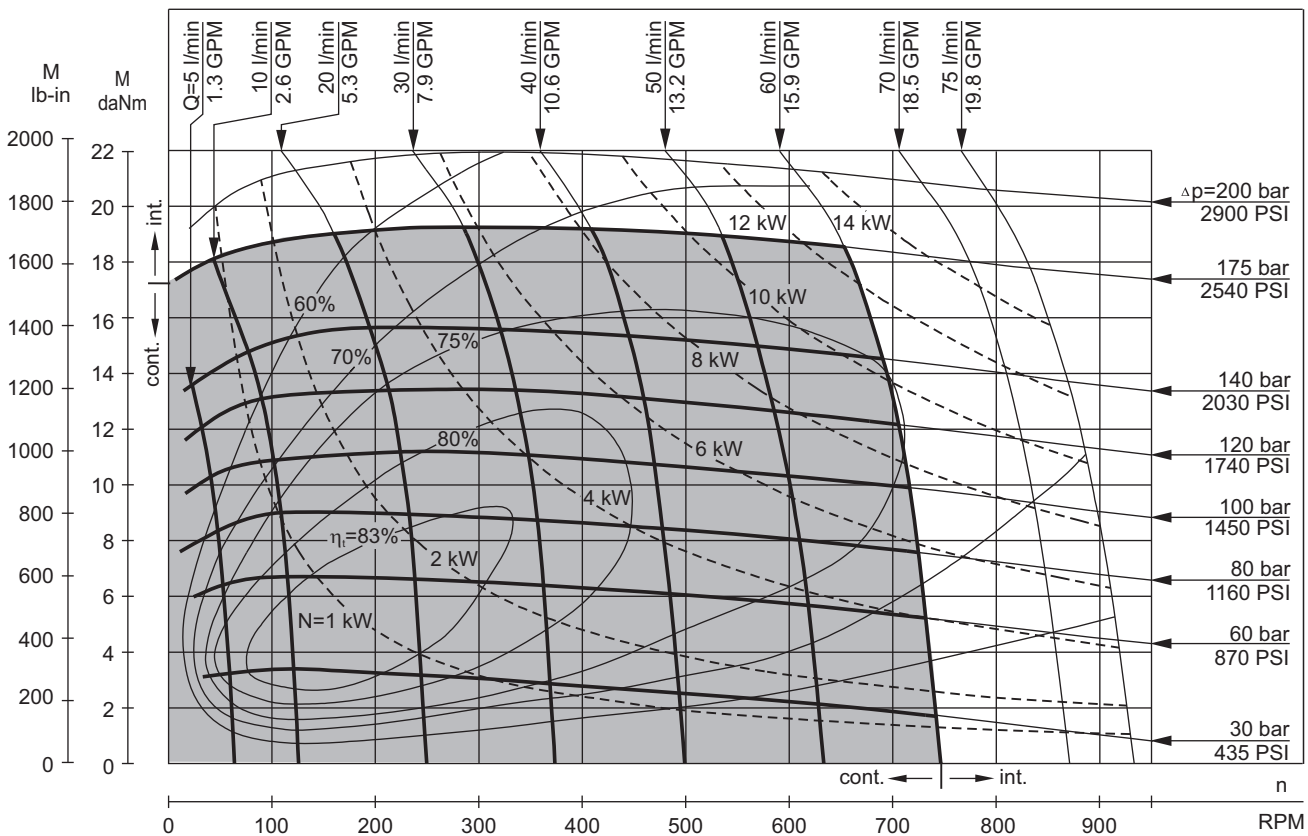

The function diagrams data is for average performance of randomly selected motors at back pressure 5±10 bar [72.5 PSI±145 PSI] and oil with viscosity of 32 mm²/s [150 SUS] at 50°C [122°F].

FUNCTION DIAGRAMS

MR 100

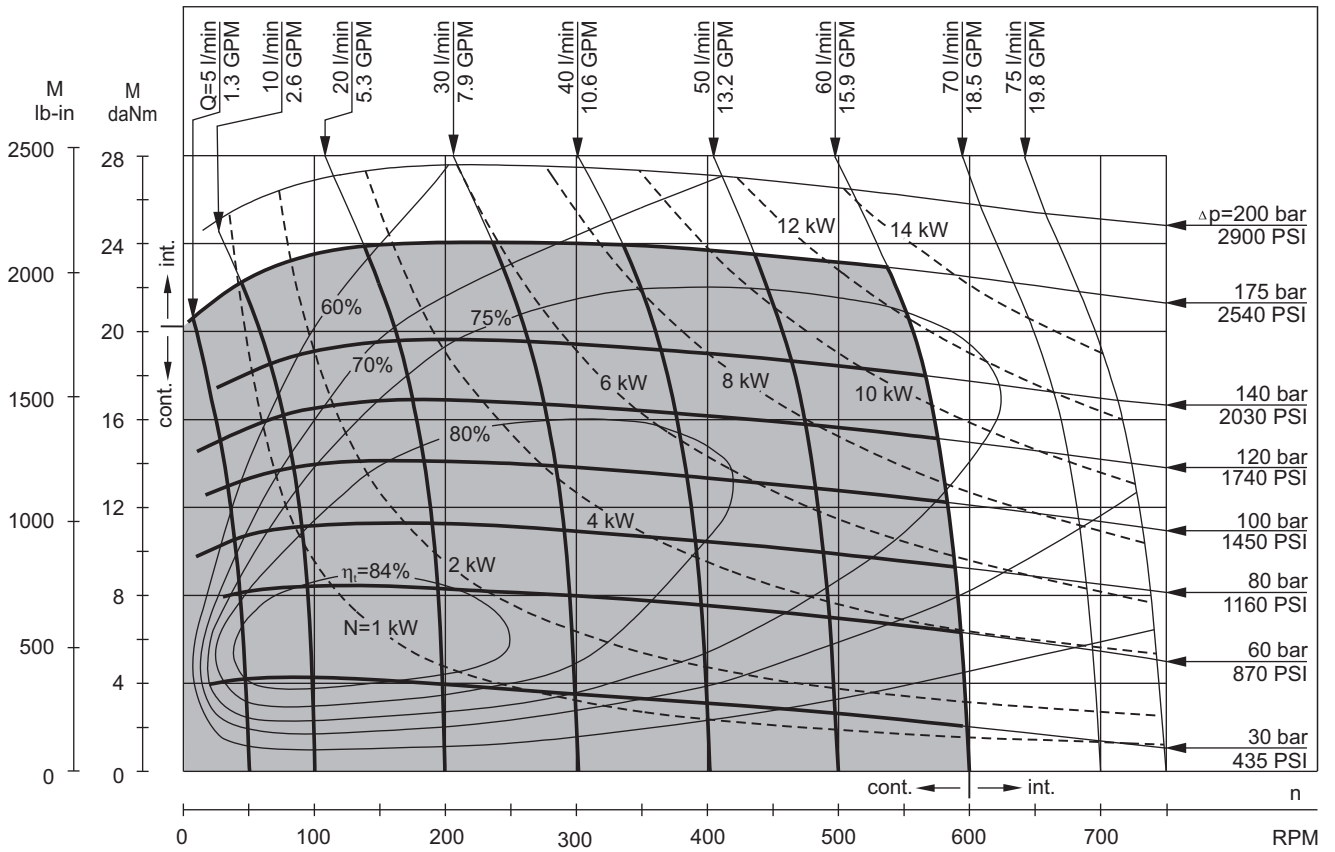

MR 125

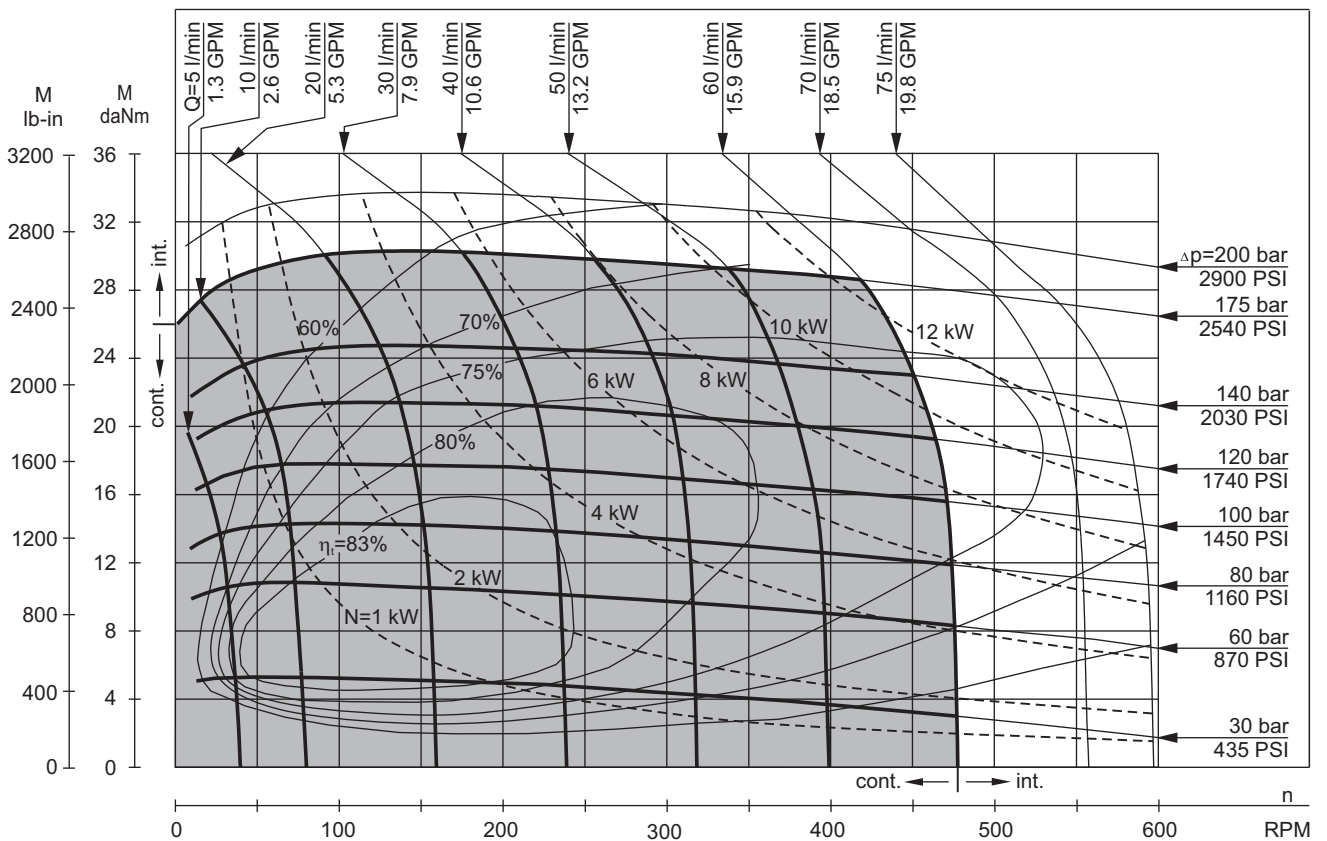

The function diagrams data is for average performance of randomly selected motors at back pressure 5±10 bar [72.5 PSI±145 PSI] and oil with viscosity of 32 mm²/s [150 SUS] at 50°C [122°F].

FUNCTION DIAGRAMS

MR 160

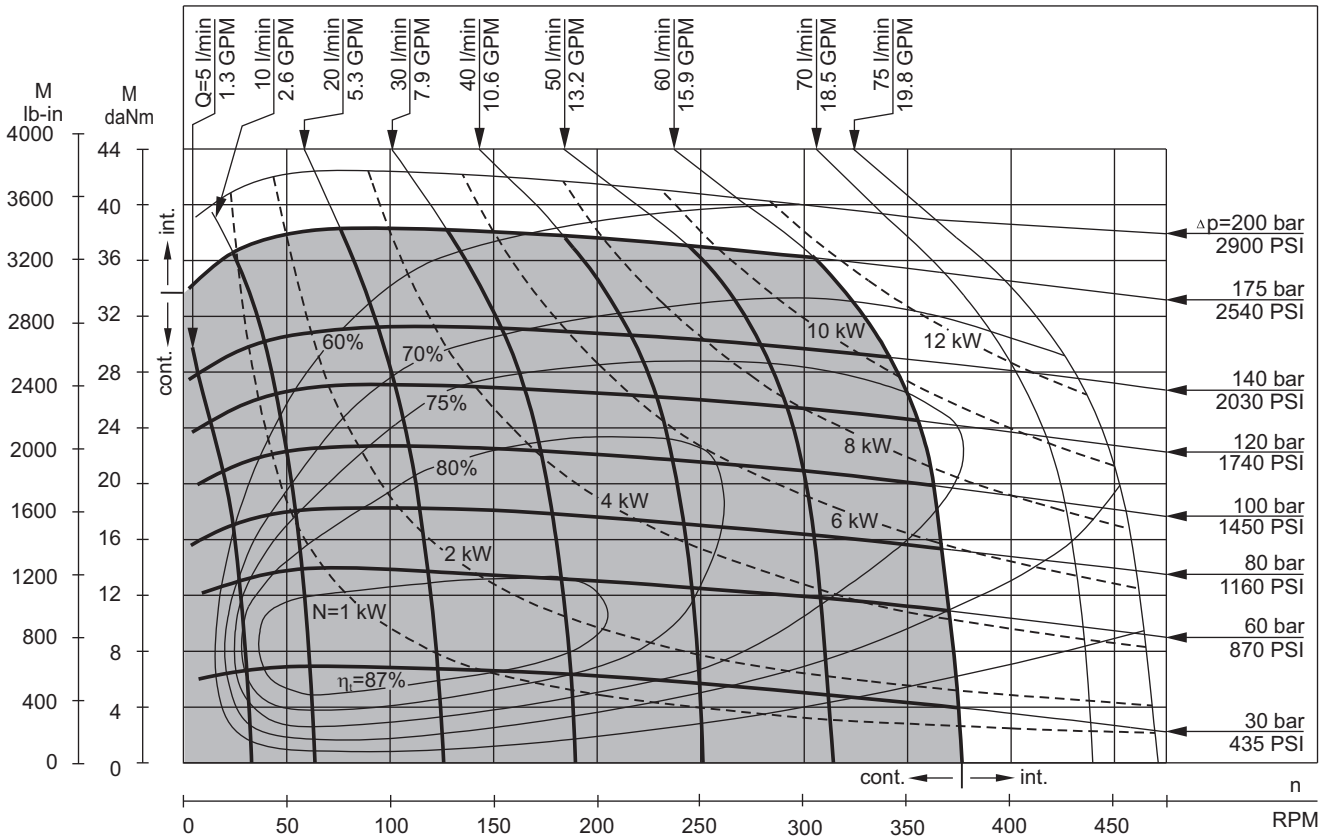

MR 200

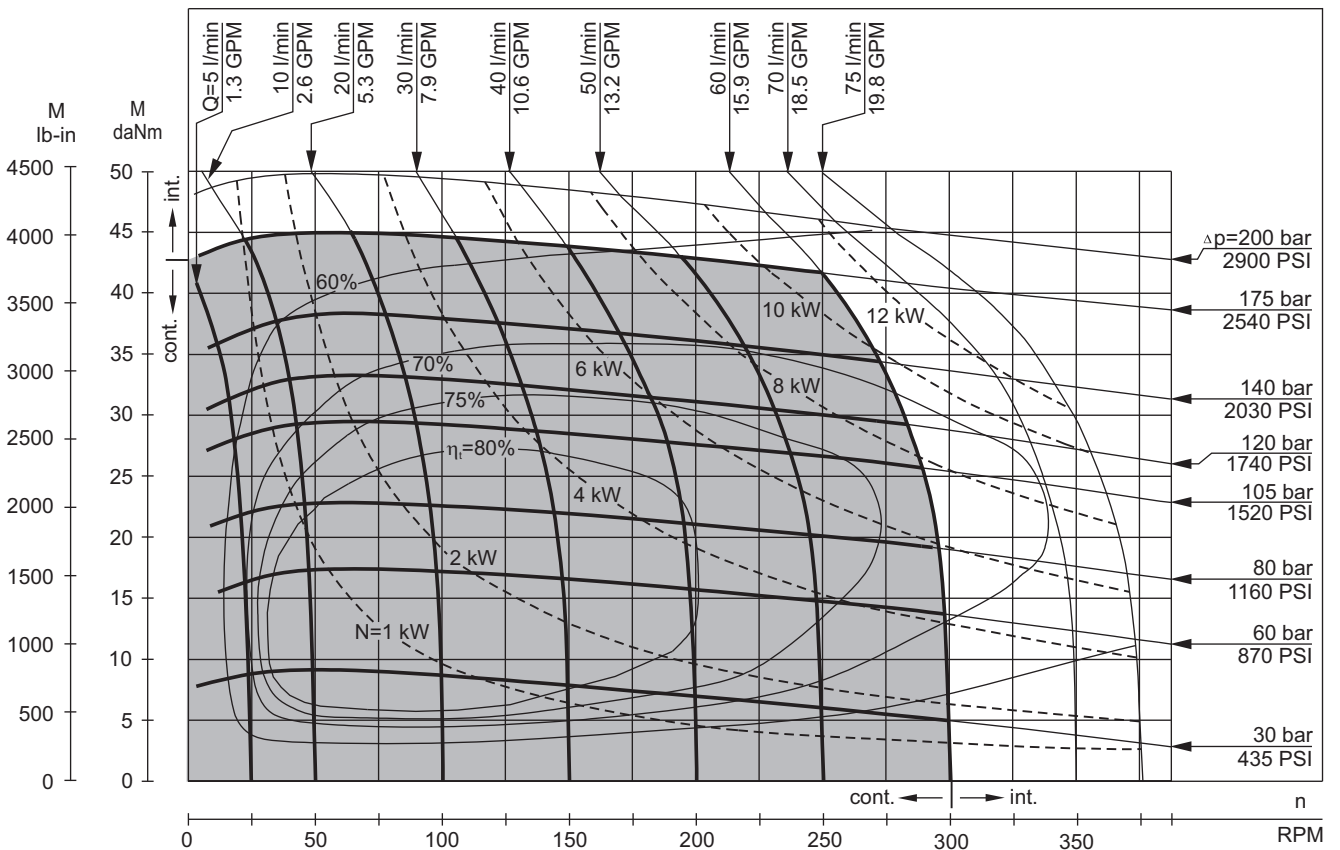

The function diagrams data is for average performance of randomly selected motors at back pressure 5±10 bar [72.5 PSI±145 PSI] and oil with viscosity of 32 mm²/s [150 SUS] at 50°C [122°F].

FUNCTION DIAGRAMS

MR 250

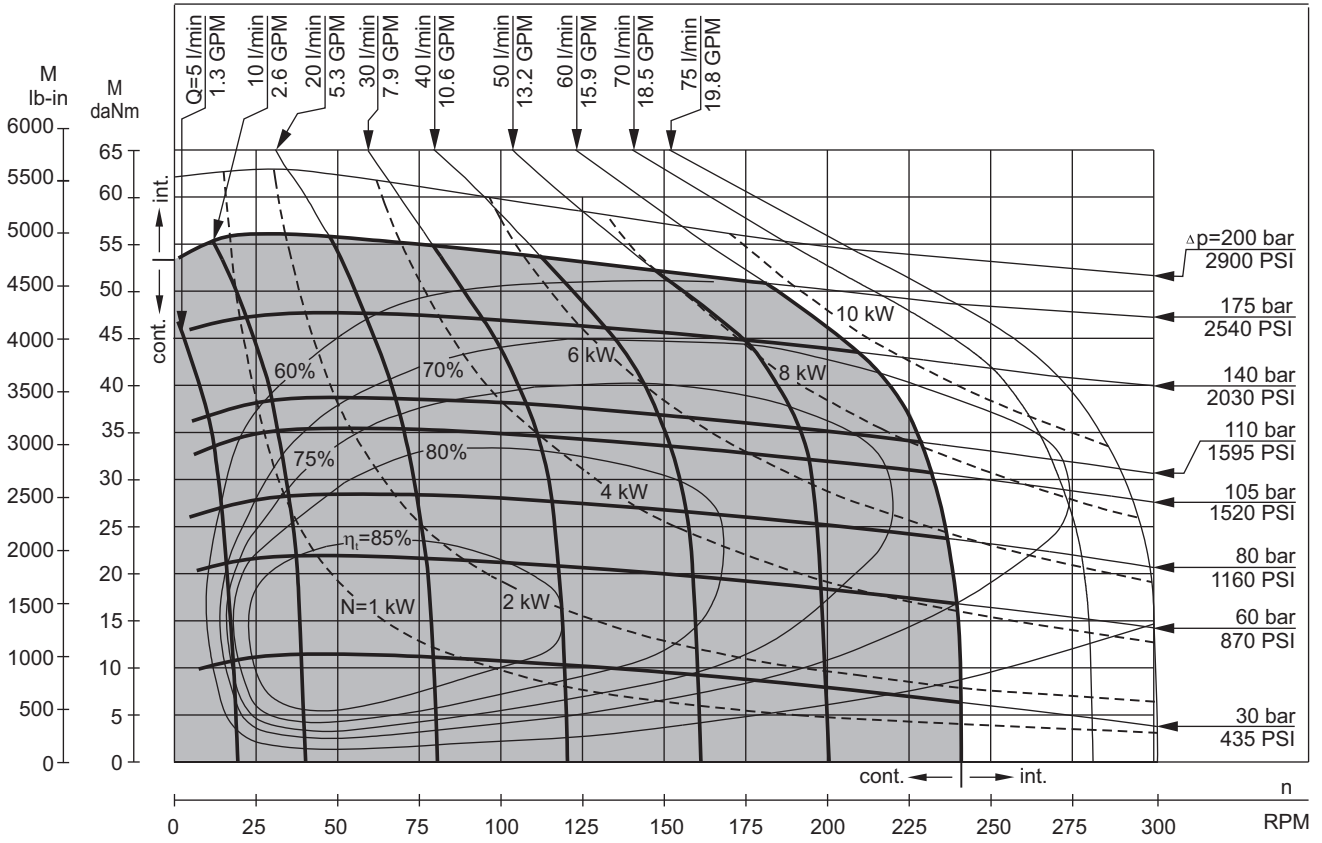

MR 315

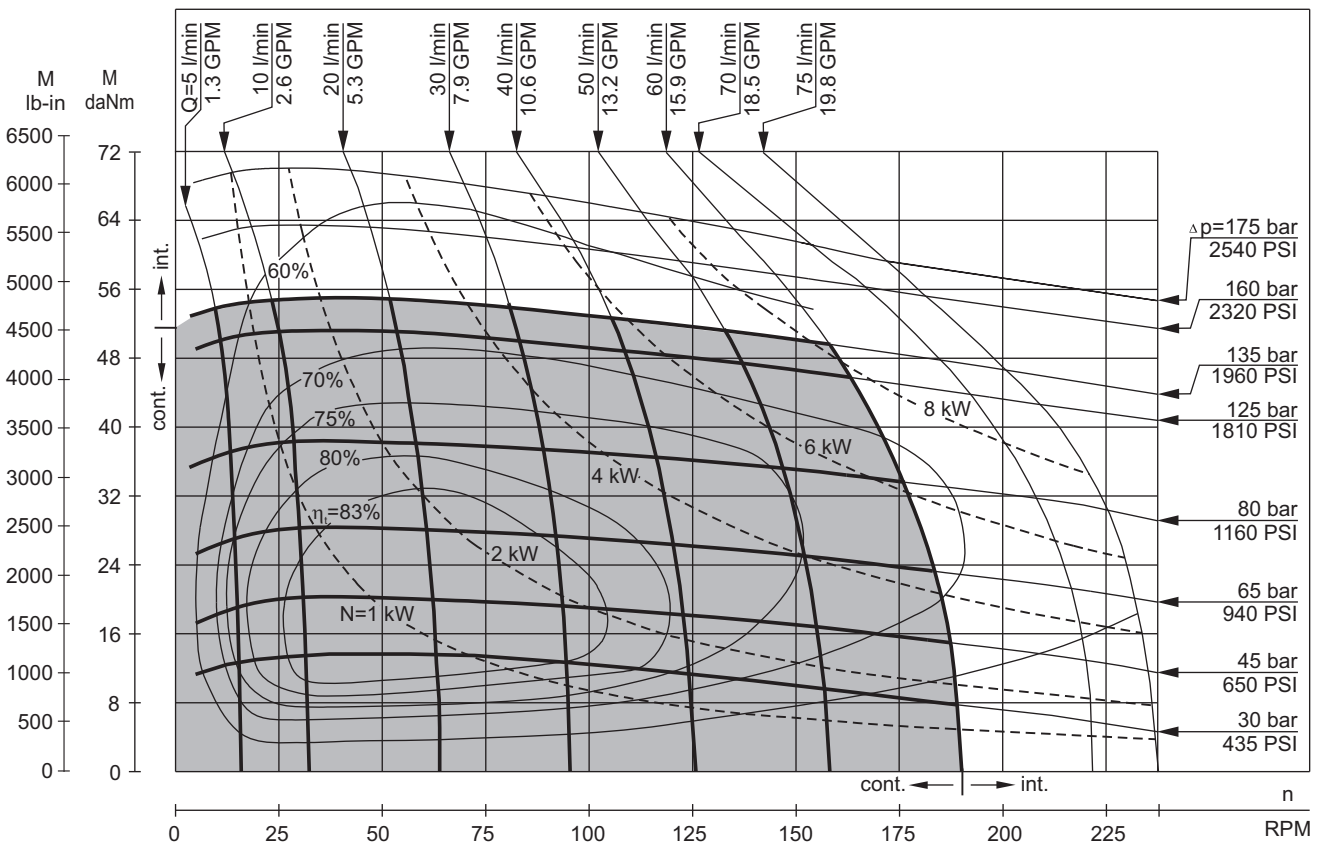

The function diagrams data is for average performance of randomly selected motors at back pressure 5±10 bar [72.5 PSI±145 PSI] and oil with viscosity of 32 mm²/s [150 SUS] at 50°C [122°F].

FUNCTION DIAGRAMS

MR 400

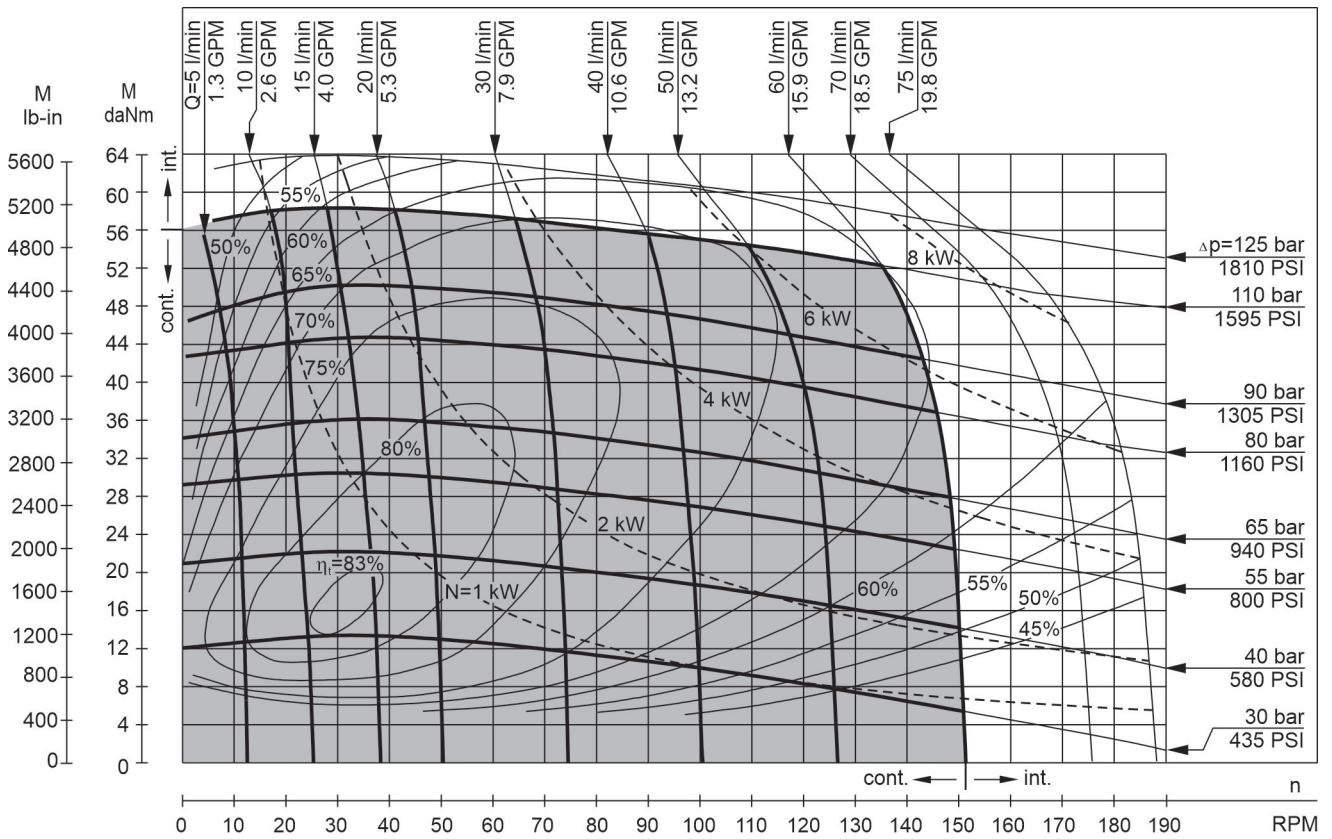

The function diagrams data is for average performance of randomly selected motors at back pressure 5±10 bar [72.5 PSI±145 PSI] and oil with viscosity of 32 mm²/s [150 SUS] at 50°C [122°F].

DIMENSIONS and MOUNTING DATA

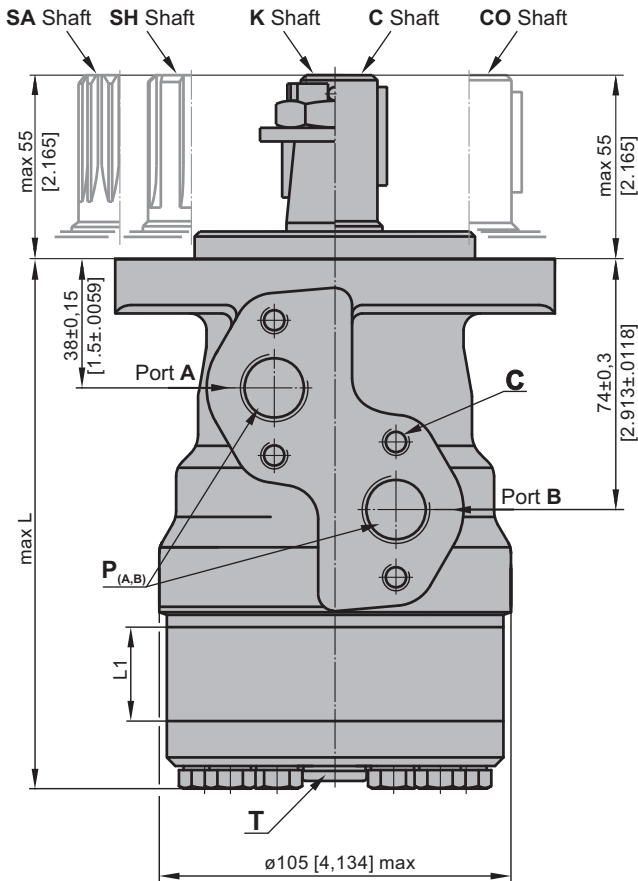

Shaft Dim.
See Page 28

Flange Dim.
See Page 41

Port Dim.
See Page 41

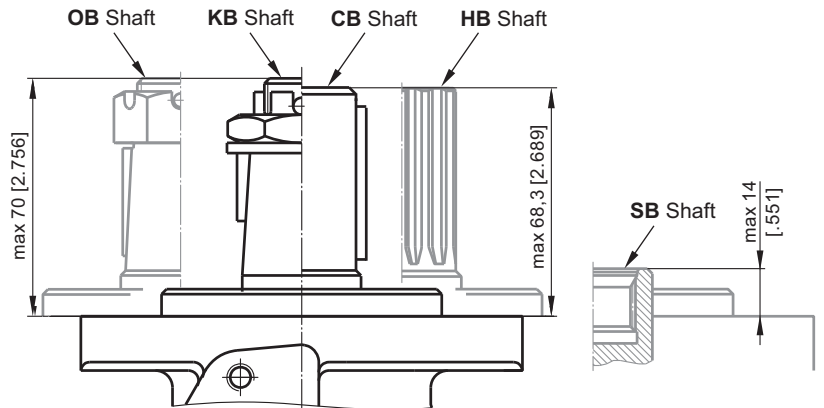
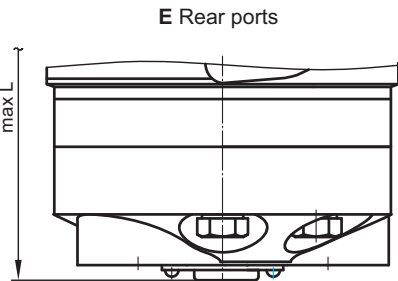
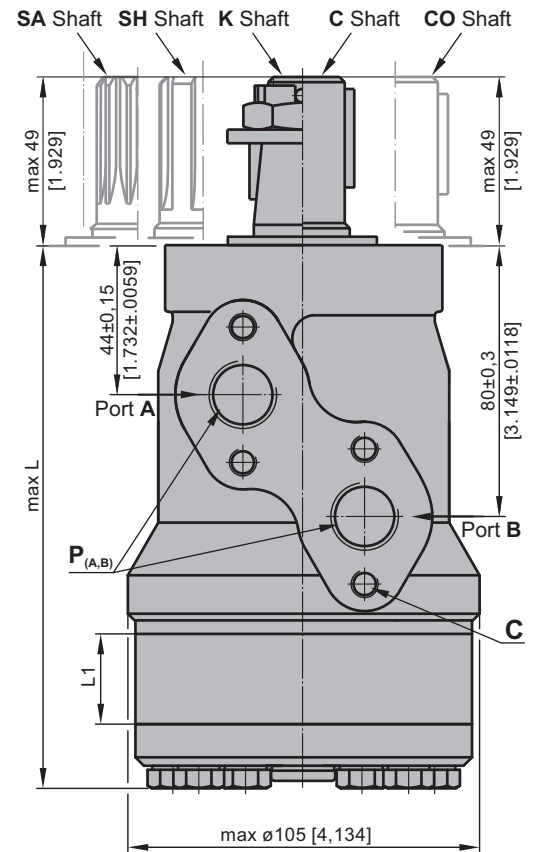

- C** : 4xM8 - 13 mm [.51 in] depth
- P_(A,B)** : 2xG1/2 or 2xM22x1,5 - 15 mm [.59 in] depth
- T** : G1/4 or M14x1,5 - 12 mm [.47 in] depth (plugged)

- | | |
|--|---|
| Standard Rotation
Viewed from Shaft End
Port A Pressurized - CW
Port B Pressurized - CCW | Reverse Rotation
Viewed from Shaft End
Port A Pressurized - CCW
Port B Pressurized - CW |
|--|---|

Type	L, mm [in]	Type	L, mm [in]	Type	L, mm [in]	Type	L, mm [in]	L1, mm [in]
MR(F) 50	138,0 [5.43]	MRQ 50	143,5 [5.65]	MR(F)E 50	157,5 [6.20]	MRQE 50	163,5 [6.44]	9,0 [.35]
MR(F) 80	143,0 [5.63]	MRQ 80	148,5 [5.85]	MR(F)E 80	162,5 [6.40]	MRQE 80	168,5 [6.63]	14,0 [.55]
MR(F) 100	146,0 [5.75]	MRQ 100	152,0 [5.98]	MR(F)E 100	165,5 [6.52]	MRQE 100	171,5 [6.75]	17,4 [.69]
MR(F) 125	150,5 [5.93]	MRQ 125	156,5 [6.16]	MR(F)E 125	170,0 [6.69]	MRQE 125	176,0 [6.93]	21,8 [.86]
MR(F) 160	156,5 [6.16]	MRQ 160	162,5 [6.40]	MR(F)E 160	176,0 [6.93]	MRQE 160	182,0 [7.17]	27,8 [1.09]
MR(F) 200	163,5 [6.44]	MRQ 200	169,5 [6.67]	MR(F)E 200	183,0 [7.20]	MRQE 200	189,0 [7.44]	34,8 [1.37]
MR(F) 250	172,0 [6.77]	MRQ 250	179,0 [7.05]	MR(F)E 250	192,0 [7.56]	MRQE 250	198,0 [7.80]	43,5 [1.71]
MR(F) 315	183,0 [7.20]	MRQ 315	189,0 [7.44]	MR(F)E 315	204,0 [8.03]	MRQE 315	210,0 [8.27]	54,8 [2.16]
MR(F) 400	198,0 [7.80]	MRQ 400	204,0 [8.03]	MR(F)E 400	218,0 [8.58]	MRQE 400	224,0 [8.82]	69,4 [2.73]

MOUNTING

Oval Mount (2 Holes)

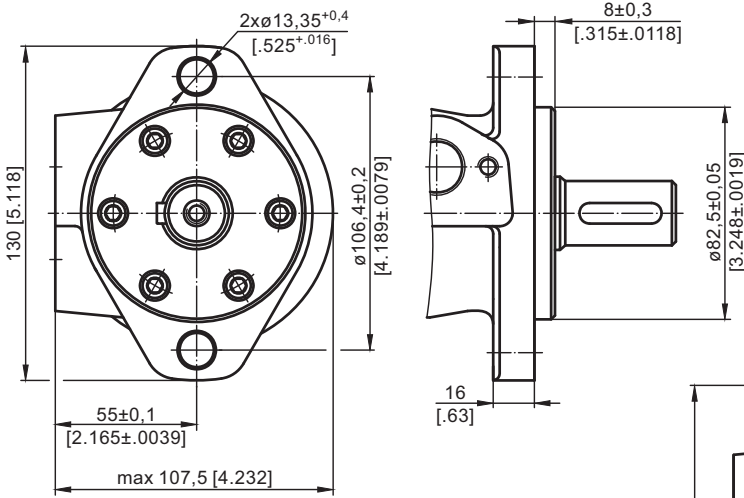

F - Oval Mount (4 Holes)

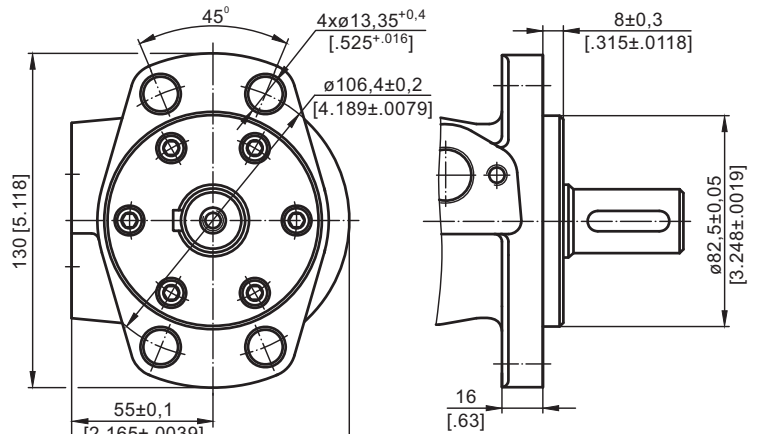

Q - Square Mount (4 Bolts)

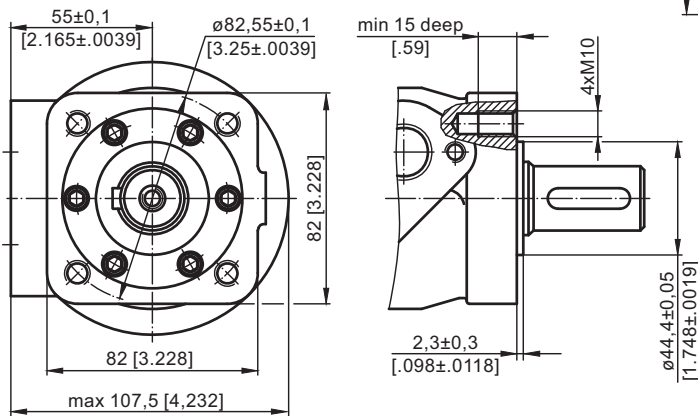

PORTS

Side Ports

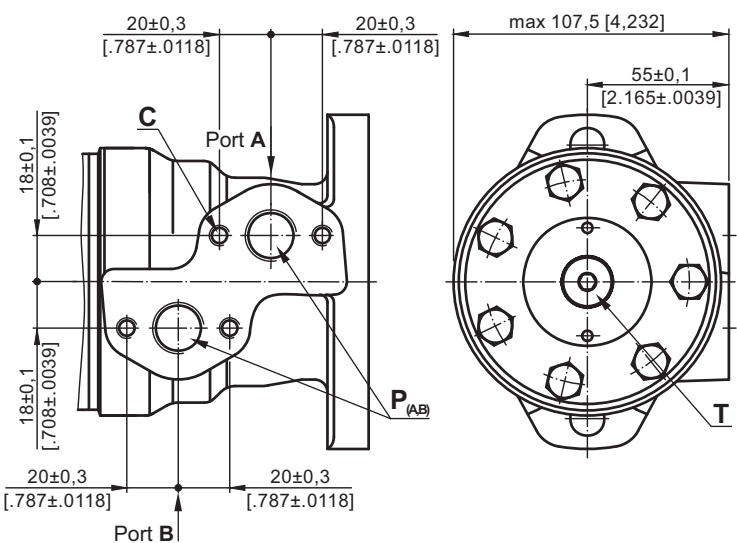

E Rear Ports

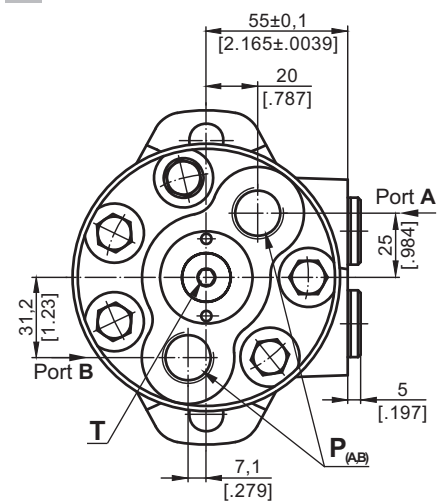

- C** : 4xM8 - 13 mm [0.51 in] depth
- P_(A,B)** : 2xG1/2 or 2xM22x1,5 - 15 mm [0.59 in] depth
- T** : G1/4 or M14x1,5 - 12 mm [0.47 in] depth (plugged)

Standard Rotation

Viewed from Shaft End
Port A Pressurized - CW
Port B Pressurized - CCW

Reverse Rotation

Viewed from Shaft End
Port A Pressurized - CCW
Port B Pressurized - CW

ORDER CODE

	1	2	3	4	5	6	7	8	9	10
MR										

Pos.1 - Mounting Flange

- omit - Oval mount, two holes
- F** - Oval mount, four holes
- Q** - Square mount, four bolts

Pos.2 - Option (needle bearings)

- omit - none
- N** - with needle bearings

Pos.3 - Port type

- omit - Side ports
- E** - Rear ports

Pos.4 - Displacement code

- 50** - 51,5 cm³/rev [3.14 in³/rev]
- 80** - 80,3 cm³/rev [4.90 in³/rev]
- 100** - 99,8 cm³/rev [6.09 in³/rev]
- 125** - 125,7 cm³/rev [7.67 in³/rev]
- 160** - 159,6 cm³/rev [9.74 in³/rev]
- 200** - 199,8 cm³/rev [12.19 in³/rev]
- 250** - 250,1 cm³/rev [15.26 in³/rev]
- 315** - 315,7 cm³/rev [19.26 in³/rev]
- 400** - 397,0 cm³/rev [24.40 in³/rev]

Pos.5 - Shaft Extensions* (see page 28)

- C** - \varnothing 25 straight, Parallel key A8x7x32 DIN6885
- VC** - \varnothing 25 straight, Parallel key A8x7x32 DIN6885 with corrosion resistant protection
- CO** - \varnothing 1" straight, Parallel key 1/4"x1/4"x1 1/4" BS46
- VCO** - \varnothing 1" straight, Parallel key 1/4"x1/4"x1 1/4" Bs46 with corrosion resistant protection
- SH** - \varnothing 25,32 splined BS 2059 (SAE 6B)
- VSH** - \varnothing 25,32 splined BS 2059 (SAE 6B) with corrosion resistant protection
- K** - \varnothing 28,56 tapered 1:10, Parallel key B5x5x14 DIN6885
- SA** - \varnothing 24,5 splined B 25x22 DIN 5482
- VSA** - \varnothing 24,5 splined B 25x22 DIN 5482 with corrosion resistant protection
- CB** - \varnothing 32 straight, Parallel key A10x8x45 DIN6885
- KB** - \varnothing 35 tapered 1:10, Parallel key B6x6x20 DIN6885
- SB** - splined A 25x22 DIN 5482
- OB** - \varnothing 1 1/4" tapered 1:8, Parallel key 5/16"x5/16"x1 1/4" BS46
- HB** - \varnothing 1 1/4" splined 14T ANSI B92.1 - 1976

Pos. 6 - Shaft Seal Version (see page 30)

- omit - Low pressure shaft seal or Standard shaft seal for "...B" shaft
- D** - 150 bar pressure seal /recommended for medium pressure and high speed and high radial load/
- U** - 200 bar pressure seal /recommended for high pressure and low speed of rotation and medium radial load/ (without check valves)

Pos. 7 - Drain Port

- omit - with drain port
- 1** - without drain port

Pos. 8 - Ports

- omit - BSPP (ISO 228)
- M** - Metric (ISO 262)

Pos. 9 - Additional Options (see page 125)

Pos.10 - Design Series

- omit - Factory specified

NOTES: The following combinations are not allowed: - **Q** flange with "...B" shafts;
 - **N** option with "...B" shafts, Low Pressure Seal or **U** option;
 - "...B" shafts with **D** and **U** shaft seals.

* The permissible output torque for shafts must not be exceeded!

The hydraulic motors are mangano-phosphatized as standard.

Hydraulic motors type MR...T with tacho connection

MR motors are available in version with tacho drive shaft. With tacho connection the speed of the motor can be registered. Tacho shaft has a 6 times higher revolution speed than output shaft and opposite direction of rotation.

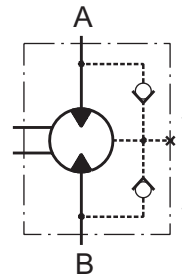

OUTLINE DIMENSIONS REFERENCE

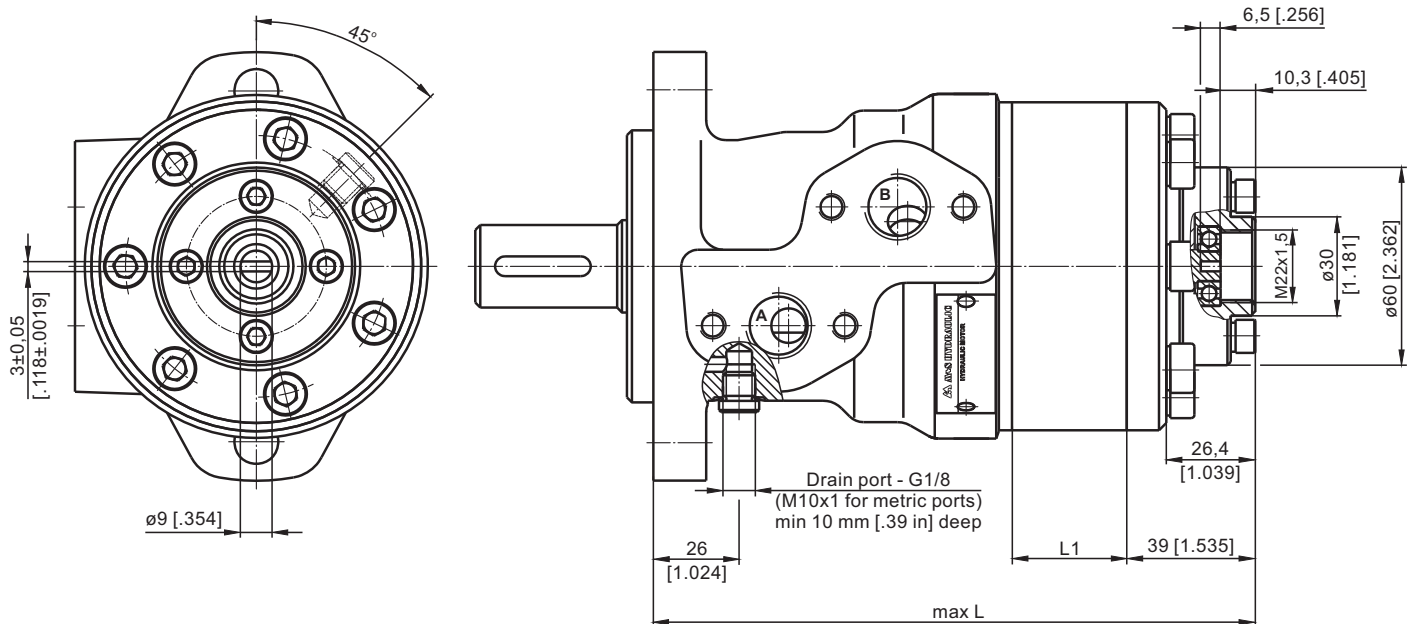

Type	L, mm [in]	L1, mm [in]
MR 50	157 [6.18]	9,0 [.35]
MR 80	162 [6.38]	14,0 [.55]
MR 100	165 [6.50]	17,4 [.69]
MR 125	170 [6.69]	21,8 [.86]
MR 160	176 [6.93]	27,8 [1.09]
MR 200	183 [7.20]	34,8 [1.37]
MR 250	192 [7.56]	43,5 [1.71]
MR 315	204 [8.03]	54,8 [2.16]
MR 400	218 [8.58]	69,4 [2.73]



mm [in]

Notes:

Radial or axial load on tacho shaft must be avoided. Max. torque on tacho shaft 0,1 daNm [.885 lb-in]. Max. cont. return pressure without drain line 20 bar [290 PSI].

Tacho option for MR motor is available only for shafts with sealing diameter ø28,56 with shaft seal type D (up to 150 bar).

It is not allowed for Q-flange.

The main technical features correspond to the standard motors series MR. There are no changes in the overall and mounting dimensions. For detail technical and mounting data please refer to MR catalogue.

HYDRAULIC MOTORS SP

M+S Hydraulic introduces a new version of hydraulic motors, type SP with new housing, integrated output shaft to the spool valve, check valves, high pressure shaft seal. The SP motors are suitable for a wide range of applications where compact and high efficient motors are required.

CONTENTS

Specification data	45÷46
Function diagrams	18÷24
Dimensions and mounting	47÷48
Shaft extensions	48
Permissible shaft seal pressure	48
Permissible shaft loads	49
Order code	49

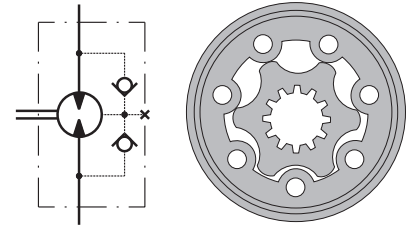

APPLICATION

- » Conveyors
- » Feeding mechanism of robots and manipulators
- » Metal working machines
- » Textile machines
- » Agriculture machines
- » Food industries
- » Grass cutting machinery etc.

OPTIONS

- » Model- Spool valve, gerotor
- » Flange mount - 2 hole oval flange; square flange
- » Side BSPP ports
- » Shafts- straight and splined
- » Shaft seal for high and low pressure
- » Other special features

GENERAL

Max. Displacement, cm ³ /rev [in ³ /rev]	396 [24.16]
Max. Speed, [RPM]	1515
Max. Torque, daNm [lb-in]	cont.:38 [3360] int.: 46 [3240]
Max. Output, kW [HP]	17,5 [23.5]
Max. Pressure Drop, bar [PSI]	cont.:140 [2030] int.:175 [2540]
Max. Oil Flow, lpm [GPM]	75 [19.8]
Min. Speed, [RPM]	10
Pressure fluid	Mineral based- HLP(DIN 51524) or HM(ISO 6743/4)
Temperature range, OC [OF]	-30÷90 [-22÷194]
Optimal Viscosity range, mm ² /s [SUS]	20÷75 [98÷347]
Filtration	ISO code: 18/16/13 According to ISO 4406-1999

Oil flow in drain line

Pressure drop bar [PSI]	Viscosity mm ² /s [SUS]	Oil flow in drain line lpm [GPM]
100 [1450]	20 [98]	2,5 [.660]
	35 [164]	1,8 [.476]
140 [2030]	20 [98]	3,5 [.925]
	35 [164]	2,8 [.740]

Pressure Losses

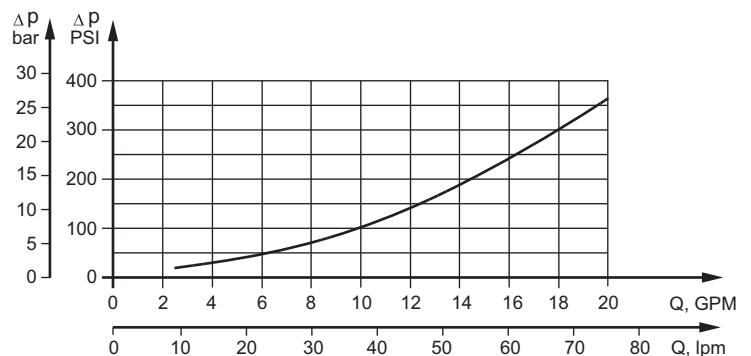

SPECIFICATION DATA

Specification Data for SP... motors with **C** and **CO** shafts.

Type		SP 50	SP 80	SP 100	SP 125	SP 160	SP 200	SP 250	SP 315	SP 400
Displacement, cm³/rev [in³/rev]		49,5 [3.0]	79,2 [4.83]	99,8 [6.09]	123,8 [7.55]	158,4 [9.66]	198 [12.1]	247,5 [15.1]	316,8 [19.3]	396 [24.2]
Max. Speed, [RPM]	Cont.	1210	755	600	486	378	303	242	190	150
	Int.*	1515	945	750	605	472	378	303	236	189
Max. Torque, daNm [lb-in]	Cont.	9,4 [835]	15,1 [1340]	24 [2125]	23,7 [2100]	30 [2655]	30 [2655]	27,6 [2440]	29,5 [2610]	28,5 [2520]
	Int.*	11,9 [1050]	19,5 [1725]	28 [2480]	29,8 [2640]	37,8 [3345]	36,5 [3230]	35,5 [3140]	36,6 [4070]	36 [3185]
	Peak**	14 [1240]	22 [1950]	32 [2830]	36,5 [3230]	42 [3720]	53 [4690]	54 [4780]	59 [5220]	59 [5220]
Max. Output, kW [HP]	Cont.	9,9 [13.3]	9,9 [13.3]	13 [17.4]	9,9 [13.3]	9,9 [13.3]	9,5 [12.7]	6 [8.1]	4 [5.4]	3 [4]
	Int.*	12,5 [16.8]	12,5 [16.8]	15 [20.1]	12,5 [16.8]	12,5 [16.8]	12,5 [16.8]	13,2 [17.7]	5,8 [7.8]	5 [6.7]
Max. Pressure Drop, bar [PSI]	Cont.	140 [2030]	140 [2030]	140 [2030]	140 [2030]	140 [2030]	115 [1670]	85 [1230]	70 [1015]	55 [800]
	Int.*	175 [2540]	175 [2540]	175 [2540]	175 [2540]	175 [2540]	140 [2030]	110 [1450]	90 [1305]	70 [1015]
	Peak**	225 [3260]	225 [3260]	225 [3260]	225 [3260]	225 [3260]	225 [3260]	180 [2610]	160 [2320]	130 [1885]
Max. Oil Flow, lpm [GPM]	Cont.	60 [15.8]	60 [15.8]	60 [15.8]	60 [15.8]	60 [15.8]	60 [15.8]	60 [15.8]	60 [15.8]	60 [15.8]
	Int.*	75 [19.8]	75 [19.8]	75 [19.8]	75 [19.8]	75 [19.8]	75 [19.8]	75 [19.8]	75 [19.8]	75 [19.8]
Max. Starting Pressure with Unloaded Shaft, bar [PSI]		10 [145]	10 [145]	10 [145]	9 [130]	8 [116]	7 [100]	6 [87]	5 [73]	5 [73]
Min. Starting Torque, daNm [lb-in]		7,7 [680]	14 [1240]	16,8 [1490]	21 [1860]	28 [2480]	28,5 [2520]	26,5 [2345]	26,5 [2345]	26,5 [2345]
Max. Inlet Pressure, bar [PSI]	Cont.	175 [2540]	175 [2540]	175 [2540]	175 [2540]	175 [2540]	175 [2540]	175 [2540]	175 [2540]	175 [2540]
	Int.*	200 [2900]	200 [2900]	200 [2900]	200 [2900]	200 [2900]	200 [2900]	200 [2900]	200 [2900]	200 [2900]
	Peak**	225 [3260]	225 [3260]	225 [3260]	225 [3260]	225 [3260]	225 [3260]	225 [3260]	225 [3260]	225 [3260]
Weight, kg [lb]		5,5 [12.1]	5,6 [12.3]	5,8 [12.8]	6,0 [13.2]	6,2 [13.7]	6,4 [14.1]	6,6 [14.6]	6,9 [15.2]	7,4 [16.3]

* Intermittent operation: the permissible values may occur for max. 10% of every minute.

** Peak load: the permissible values may occur for max. 1% of every minute.

*** For speeds lower than given, consult factory or your regional manager.

1. Intermittent speed and intermittent pressure must not occur simultaneously.
2. Recommended filtration is per ISO cleanliness code 20/16. A nominal filtration of 25 micron or better.
3. Recommend using a premium quality, anti-wear type mineral based hydraulic oil HLP(DIN51524) or HM (ISO 6743/4).
If using synthetic fluids consult the factory for alternative seal materials.
4. Recommended minimum oil viscosity 13 mm²/s [70 SUS] at 50°C [122°F].
5. Recommended maximum system operating temperature is 82°C [180°F].
6. To assure optimum motor life fill with fluid prior to loading and run at moderate load and speed for 10-15 minutes.

SPECIFICATION DATA

Specification Data for SP... motors with **SH** shafts.

Type		SP 50	SP 80	SP 100	SP 125	SP 160	SP 200	SP 250	SP 315	SP 400
Displacement, cm³/rev [in³/rev]		49,5 [3.0]	79,2 [4.83]	99 [6.04]	123,8 [7.55]	158,4 [9.66]	198 [12.1]	247,5 [15.1]	316,8 [19.3]	396 [24.2]
Max. Speed, [RPM]	Cont.	1210	755	605	486	378	303	242	190	150
	Int.*	1515	945	755	605	472	378	303	236	189
Max. Torque, daNm [lb-in]	Cont.	9,4 [835]	15,1 [1340]	19,3 [1710]	23,7 [2100]	30 [2655]	36,6 [3240]	38 [3360]	38 [3360]	36 [3190]
	Int.*	11,9 [1050]	19,5 [1725]	23,7 [2100]	29,8 [2640]	37,8 [3345]	45,6 [4035]	45 [3980]	46 [3240]	46 [3240]
	Peak**	14 [1240]	22 [1950]	27 [2390]	36,5 [3230]	42 [3720]	53 [4690]	67 [5930]	85 [7520]	85 [7520]
Max. Output, kW [HP]	Cont.	9,9 [13.3]	9,9 [13.3]	9,9 [13.3]	9,9 [13.3]	9,9 [13.3]	10,3 [13.8]	8 [10.7]	6 [8.1]	4,8 [6.4]
	Int.*	12,5 [16.8]	12,5 [16.8]	12,5 [16.8]	12,5 [16.8]	12,5 [16.8]	15,3 [20.5]	17,5 [23.5]	8,2 [10.9]	9,2 [12.3]
Max. Pressure Drop, bar [PSI]	Cont.	140 [2030]	140 [2030]	140 [2030]	140 [2030]	140 [2030]	140 [2030]	110 [1450]	90 [1305]	70 [1015]
	Int.*	175 [2540]	175 [2540]	175 [2540]	175 [2540]	175 [2540]	175 [2540]	140 [2030]	140 [2030]	90 [1305]
	Peak**	225 [3260]	225 [3260]	225 [3260]	225 [3260]	225 [3260]	225 [3260]	225 [3260]	225 [3260]	180 [2610]
Max. Oil Flow, lpm [GPM]	Cont.	60 [15.8]	60 [15.8]	60 [15.8]	60 [15.8]	60 [15.8]	60 [15.8]	60 [15.8]	60 [15.8]	60 [15.8]
	Int.*	75 [19.8]	75 [19.8]	75 [19.8]	75 [19.8]	75 [19.8]	75 [19.8]	75 [19.8]	75 [19.8]	75 [19.8]
Max. Starting Pressure with Unloaded Shaft, bar [PSI]		10 [145]	10 [145]	10 [145]	9 [130]	8 [116]	7 [100]	6 [87]	5 [73]	5 [73]
Min. Starting Torque, daNm [lb-in]		7,7 [680]	14 [1240]	16,8 [1490]	21 [1860]	28 [2480]	34,6 [3060]	34,5 [3050]	35 [3100]	35 [3100]
Max. Inlet Pressure, bar [PSI]	Cont.	175 [2540]	175 [2540]	175 [2540]	175 [2540]	175 [2540]	175 [2540]	175 [2540]	175 [2540]	175 [2540]
	Int.*	200 [2900]	200 [2900]	200 [2900]	200 [2900]	200 [2900]	200 [2900]	200 [2900]	200 [2900]	200 [2900]
	Peak**	225 [3260]	225 [3260]	225 [3260]	225 [3260]	225 [3260]	225 [3260]	225 [3260]	225 [3260]	225 [3260]
Weight, kg [lb]		5,5 [12.1]	5,6 [12.3]	5,8 [12.8]	6,0 [13.2]	6,2 [13.7]	6,4 [14.1]	6,6 [14.6]	6,6 [14.6]	7,4 [16.3]

* Intermittent operation: the permissible values may occur for max. 10% of every minute.

** Peak load: the permissible values may occur for max. 1% of every minute.

*** For speeds lower than given, consult factory or your regional manager.

1. Intermittent speed and intermittent pressure must not occur simultaneously.
2. Recommended filtration is per ISO cleanliness code 20/16. A nominal filtration of 25 micron or better.
3. Recommend using a premium quality, anti-wear type mineral based hydraulic oil HLP(DIN51524) or HM (ISO 6743/4).
If using synthetic fluids consult the factory for alternative seal materials.
4. Recommended minimum oil viscosity 13 mm²/s [70 SUS] at 50°C [122°F].
5. Recommended maximum system operating temperature is 82°C [180°F].
6. To assure optimum motor life fill with fluid prior to loading and run at moderate load and speed for 10-15 minutes.

DIMENSIONS and MOUNTING DATA

SP

SPQ

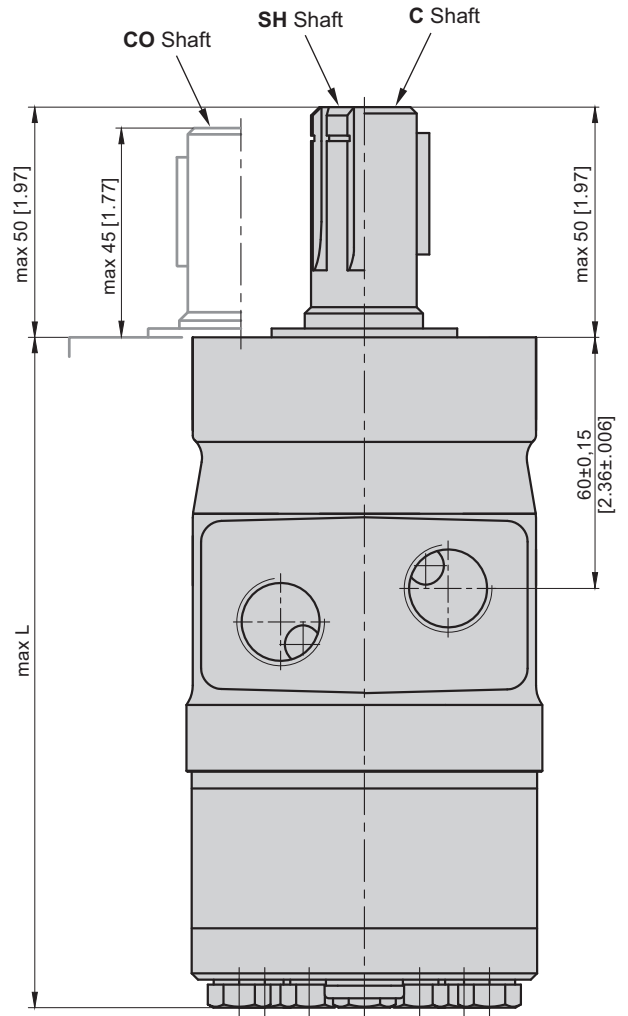
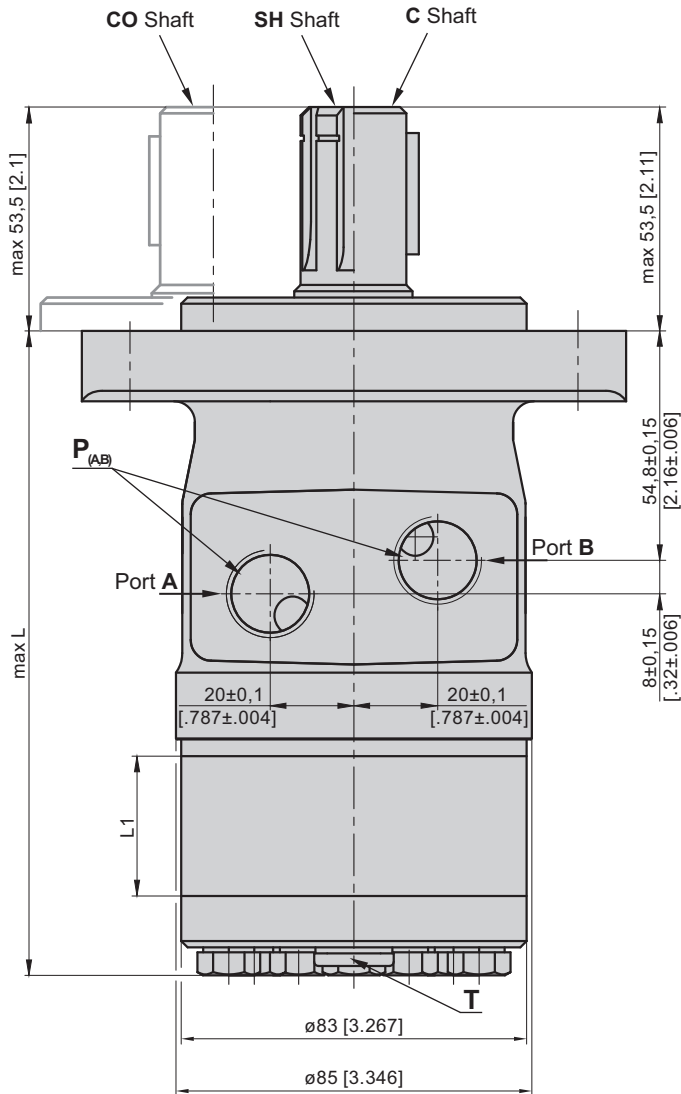

P_(A,B): 2xG1/2 - 18 mm [.709 in] depth
T: G1/4 - 12 mm [.470 in] depth

Standard Rotation
Viewed from Shaft End
Port A Pressurized - **CW**
Port B Pressurized - **CCW**

Reverse Rotation
Viewed from Shaft End
Port A Pressurized - **CCW**
Port B Pressurized - **CW**

Type	L _{max} , mm [in]	Type	L _{max} , mm [in]	L ₁ , mm [in]
SP 50	128,0 [5.04]	SPQ 50	134,0 [5.28]	6,67 [.26]
SP 80	132,0 [5.19]	SPQ 80	138,0 [5.43]	10,67 [.42]
SP 100	134,5 [5.29]	SPQ 100	140,9 [5.55]	13,33 [.52]
SP 125	138,0 [5.43]	SPQ 125	144,0 [5.67]	16,67 [.66]
SP 160	142,5 [5.61]	SPQ 160	148,9 [5.86]	21,33 [.84]
SP 200	148,0 [5.83]	SPQ 200	154,0 [6.06]	26,67 [1.05]
SP 250	154,5 [6.08]	SPQ 250	160,9 [6.33]	33,33 [1.31]
SP 315	164,0 [6.46]	SPQ 315	170,0 [6.69]	42,67 [1.68]
SP 400	174,5 [6.87]	SPQ 400	180,9 [7.12]	53,33 [2.10]



MOUNTING

Oval Mount (2 Holes)

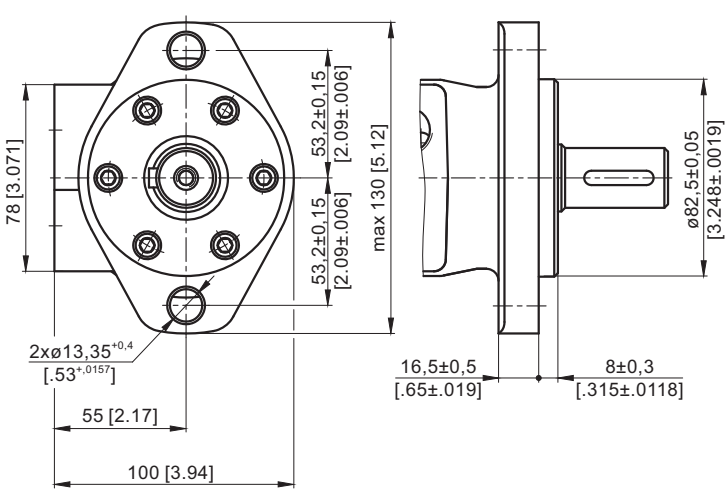

Q Square Mount
(4 bolts)

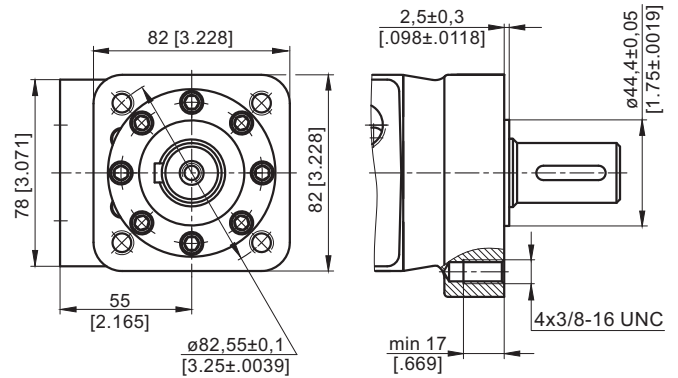

SHAFT EXTENSIONS

C - ø25 straight, Parallel key A8x7x30 DIN 6885
Max. Torque 34 daNm [3010 lb-in]

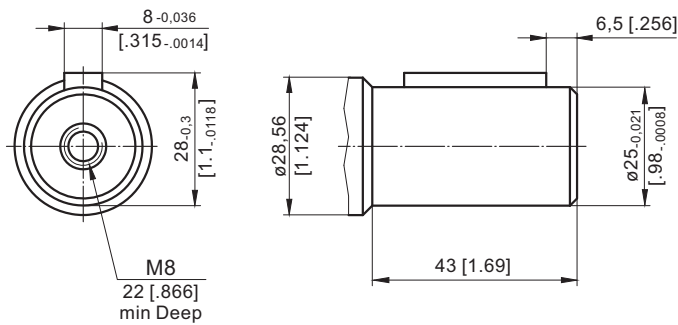

CO - ø1" straight, Parallel key 1/4"x1/4"x1" BS46
Max. Torque 34 daNm [3010 lb-in]

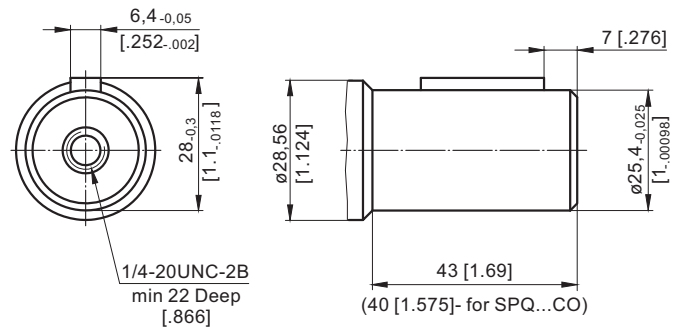

SH - splined, BS 2059 (SAE 6B)
Max. Torque 40 daNm [3540 lb-in]

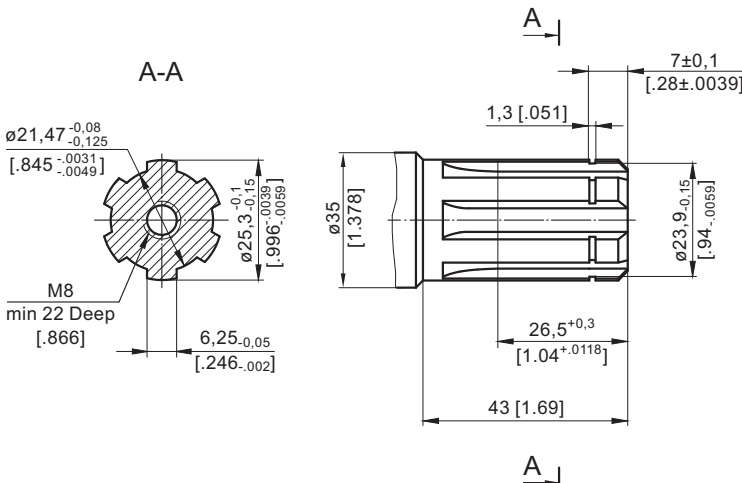

MAX. PERMISSIBLE SHAFT SEAL PRESSURE

Max return pressure without drain line or max. pressure in drain line

— - continuous operations
- - - - intermittent operations

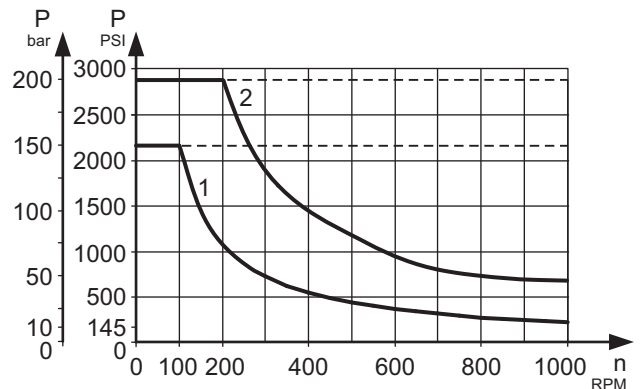

1: Curve for Standard Shaft Seal

2: Curve for High Pressure Seal ("U" Seal)



PERMISSIBLE SHAFT LOADS

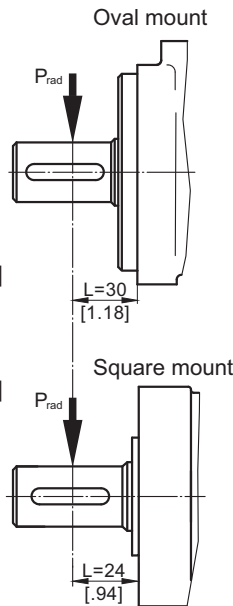

$P_{max}=150 \text{ daN}$
[330 lbs]

$P_{max}=200 \text{ daN}$
[440 lbs]

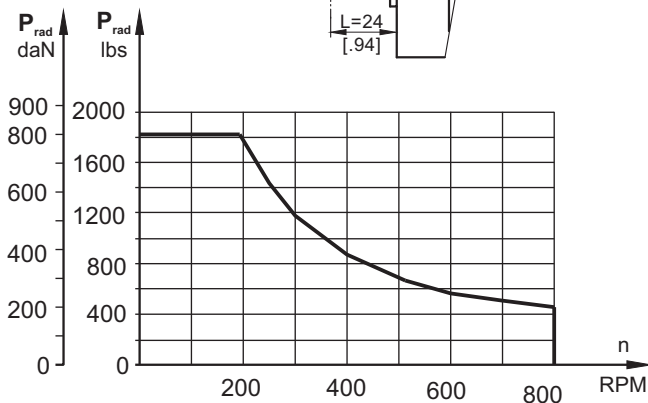

Radial Shaft Load P_{rad} for C, CO Shaft Extensions by $L=30 \text{ mm}$ [1.18 in] (24 mm [.94 in])

The permissible radial shaft load depends on

- Speed (n)
- Distance (L) from the pointload to the mounting flange
- Mounting flange version

$$\text{Oval mount: } P_{rad} = \frac{800}{n} \times \frac{24300}{91,5+L} \text{ [daN]}^*$$

$$\left[\frac{800}{\text{RPM}} \times \frac{2150}{3.6+L} \text{ [lbs]} \right]$$

$$\text{Square mount: } P_{rad} = \frac{800}{n} \times \frac{24300}{97,5+L} \text{ [daN]}^*$$

$$\left[\frac{800}{\text{RPM}} \times \frac{2150}{3.84+L} \text{ [lbs]} \right]$$

* $n \leq 200 \text{ RPM}$; max $P_{rad}=800 \text{ daN}$ [1800lbs]

$n \geq 200 \text{ RPM}$; $L < 55 \text{ mm}$ [2.2 in]

ORDER CODE

1	2	3	4	5	6
SP					

Pos.1 - Mounting Flange

- omit - Oval mount, two holes
- Q** - Square mount, four bolts - 3/8-16 UNC

Pos.2 - Displacement code*

50	- 49,5 cm ³ /rev [3.02 in ³ /rev]
80	- 79,2 cm ³ /rev [4.83 in ³ /rev]
100	- 99,0 cm ³ /rev [6.04 in ³ /rev]
125	- 123,8 cm ³ /rev [7.55 in ³ /rev]
160	- 158,4 cm ³ /rev [9.66 in ³ /rev]
200	- 198,0 cm ³ /rev [12.10 in ³ /rev]
250	- 247,5 cm ³ /rev [15.10 in ³ /rev]
315	- 316,8 cm ³ /rev [19.30 in ³ /rev]
400	- 396,0 cm ³ /rev [24.16 in ³ /rev]

Pos.3 - Shaft Extensions**

- C** - $\varnothing 25$ straight, Parallel key A8x7x30 DIN6885
- CO** - $\varnothing 1"$ straight, Parallel key $1/4" \times 1/4" \times 1/4"$ BS46
- SH** - $\varnothing 25,3$ splined, BS 2059 (SAE 6B)

Pos.4 - Shaft Seal Version

- omit - Standard shaft seal
- U** - High pressure shaft seal

Pos.5 - Additional Options (see page 125)

Pos.6 - Design Series

- omit - Factory specified

NOTES: * For the Function Diagrams data please look at "M+S Hydraulic" Catalogue for MP motors, pages 18+24.

** The permissible output torque for shafts must not be exceeded!

The hydraulic motors are manganophosphatized as standard.

HYDRAULIC MOTORS SR

M+S Hydraulic introduces a new version of hydraulic motors, type SR with new housing, integrated output shaft to the spool valve, check valves, high pressure shaft seal. The SR motors are suitable for a wide range of applications where compact and high efficient motors are required.

CONTENTS

Specification data	51+53
Function diagrams	35+39
Dimensions and mounting	54+56
Shaft extensions	57
Permissible shaft seal pressure	57
Permissible shaft loads	58
Order code	58

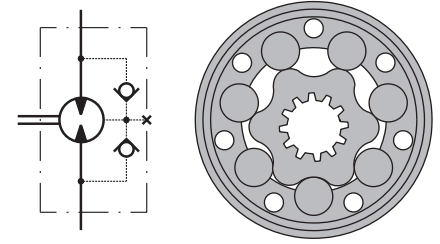

APPLICATION

- » Conveyors
- » Feeding mechanism of robots and manipulators
- » Metal working machines
- » Textile machines
- » Agriculture machines
- » Food industries
- » Grass cutting machinery etc.

OPTIONS

- » Model - Spool valve, geroller
- » Flange mount - 2 hole oval flange; 6 hole oval flange; square flange
- » Side BSPP ports
- » Shafts- straight, splined and tapered
- » Shaft seal for high and low pressure
- » Other special features

GENERAL

Max. Displacement, cm ³ /rev [in ³ /rev]	397 [24.4]
Max. Speed, [RPM]	970
Max. Torque, daNm [lb-in]	cont.: 60 [5310] int.: 69 [6107]
Max. Output, kW [HP]	15 [20.1]
Max. Pressure Drop, bar [PSI]	cont.: 175 [2540] int.: 200 [2900]
Max. Oil Flow, lpm [GPM]	75 [19.8]
Min. Speed, [RPM]	10
Pressure fluid	Mineral based- HLP(DIN 51524) or HM(ISO 6743/4)
Temperature range, °C [°F]	-30÷90 [-22÷194]
Optimal Viscosity range, mm ² /s [SUS]	20÷75 [98÷347]
Filtration	ISO code: 18/16/13 According to ISO 4406-1999

Oil flow in drain line

Pressure drop bar [PSI]	Viscosity mm ² /s [SUS]	Oil flow in drain line lpm [GPM]
100 [1450]	20 [98]	2,5 [.660]
	35 [164]	1,8 [.476]
140 [2030]	20 [98]	3,5 [.925]
	35 [164]	2,8 [.740]

Pressure Losses

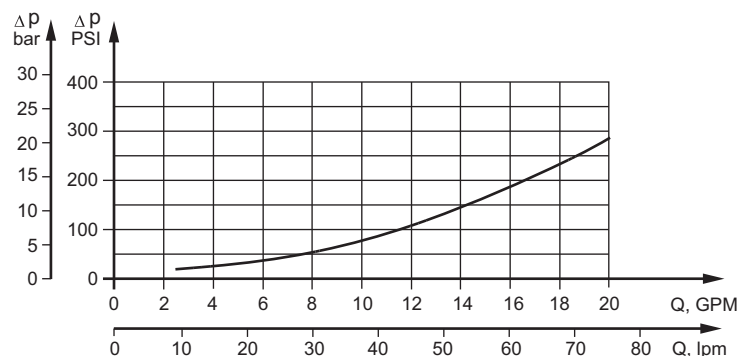

SPECIFICATION DATA

Specification Data for SR... motors with **C** and **CO** shafts.

Type		SR 50	SR 80	SR 100	SR 125	SR 160	SR 200	SR 250	SR 315	SR 400
Displacement, cm³/rev [in³/rev]		51,5 [3.14]	80,3 [4.90]	99,8 [6.09]	125,7 [7.67]	159,6 [9.74]	199,8 [12.19]	250,1 [15.26]	315,7 [19.26]	397 [24.4]
	Max. Speed, [RPM]	775	750	600	475	375	300	240	190	150
Max. Torque, daNm [lb-in]	Cont.	10 [900]	20 [1770]	24 [2125]	30 [2655]	29 [2565]	29 [2565]	30 [2655]	30 [2655]	30 [2655]
	Int.*	13 [1150]	22 [1940]	28 [2480]	34 [3010]	39 [3450]	39 [3450]	39 [3450]	42 [3717]	40 [3540]
	Peak**	17 [1505]	27 [2390]	32 [2830]	37 [3275]	46 [4070]	56 [4960]	60 [5310]	61 [5400]	61 [5400]
Max. Output, kW [HP]	Cont.	7 [9.4]	12,5 [17]	13 [17.4]	12,5 [17]	9 [12]	7,5 [10]	6 [8.1]	5 [6.7]	3,8 [5.1]
	Int.*	8,5 [11.4]	15 [20.1]	15 [20.1]	14,5 [19.5]	12,5 [17]	10 [13.4]	8 [10.7]	6,5 [8.7]	6,1 [8.2]
Max. Pressure Drop, bar [PSI]	Cont.	140 [2030]	175 [2540]	175 [2540]	175 [2540]	120 [1740]	105 [1520]	80 [1160]	70 [1015]	55 [800]
	Int.*	175 [2540]	200 [2900]	200 [2900]	200 [2900]	175 [2540]	140 [2030]	110 [1600]	100 [1450]	70 [1015]
	Peak**	225 [3260]	225 [3260]	225 [3260]	225 [3260]	225 [3260]	225 [3260]	200 [2900]	150 [2175]	115 [1670]
Max. Oil Flow, lpm [GPM]	Cont.	40 [10.5]	60 [15.8]	60 [15.8]	60 [15.8]	60 [15.8]	60 [15.8]	60 [15.8]	60 [15.8]	60 [15.8]
	Int.*	50 [13.2]	75 [19.8]	75 [19.8]	75 [19.8]	75 [19.8]	75 [19.8]	75 [19.8]	75 [19.8]	75 [19.8]
Max. Starting Pressure with Unloaded Shaft, bar [PSI]		10 [145]	10 [145]	10 [145]	9 [130]	7 [102]	5 [73]	4 [58]	3 [43.5]	3 [43.5]
Min. Starting Torque, daNm [lb-in]		8 [710]	15 [1330]	20 [1770]	24 [2125]	23 [2035]	23 [2035]	24 [2125]	26 [2300]	26 [2300]
Max. Inlet Pressure, bar [PSI]	Cont.	175 [2540]	175 [2540]	175 [2540]	175 [2540]	175 [2540]	175 [2540]	175 [2540]	175 [2540]	175 [2540]
	Int.*	200 [2900]	200 [2900]	200 [2900]	200 [2900]	200 [2900]	200 [2900]	200 [2900]	200 [2900]	200 [2900]
	Peak**	225 [3260]	225 [3260]	225 [3260]	225 [3260]	225 [3260]	225 [3260]	225 [3260]	225 [3260]	225 [3260]
Weight, kg [lb]		7,2 [15.9]	7,5 [16.5]	7,7 [16.9]	8,0 [17.6]	8,3 [18.3]	8,6 [18.9]	9,1 [20.1]	9,8 [21.6]	10,1 [22.3]

* Intermittent operation: the permissible values may occur for max. 10% of every minute.

** Peak load: the permissible values may occur for max. 1% of every minute.

*** For speeds lower than given, consult factory or your regional manager.

1. Intermittent speed and intermittent pressure must not occur simultaneously.
2. Recommended filtration is per ISO cleanliness code 20/16. A nominal filtration of 25 micron or better.
3. Recommend using a premium quality, anti-wear type mineral based hydraulic oil HLP(DIN51524) or HM (ISO 6743/4).
If using synthetic fluids consult the factory for alternative seal materials.
4. Recommended minimum oil viscosity 13 mm²/s [70 SUS] at 50°C [122°F].
5. Recommended maximum system operating temperature is 82°C [180°F].
6. To assure optimum motor life fill with fluid prior to loading and run at moderate load and speed for 10-15 minutes.

SPECIFICATION DATA

Specification Data for SR... motors with SH shafts.

Type		SR 50	SR 80	SR 100	SR 125	SR 160	SR 200	SR 250	SR 315	SR 400
Displacement, cm ³ /rev [in ³ /rev]		51,5 [3.14]	80,3 [4.90]	99,8 [6.09]	125,7 [7.67]	159,6 [9.74]	199,8 [12.19]	250,1 [15.26]	315,7 [19.26]	397 [24.4]
	Cont.	775	750	600	475	375	300	240	190	150
Max. Speed, [RPM]	Int.*	970	940	750	600	470	375	300	240	190
	Cont.	10 [900]	20 [1770]	24 [2125]	30 [2655]	39 [3450]	38,5 [3410]	38 [3360]	39 [3450]	38 [3360]
Max. Torque, daNm [lb-in]	Int.*	13 [1150]	22 [1940]	28 [2480]	34 [3010]	43 [3805]	46 [4070]	47 [4160]	48 [4250]	47 [4160]
	Peak**	17 [1505]	27 [2390]	32 [2830]	37 [3275]	46 [4070]	56 [4960]	60 [5310]	61 [5400]	61 [5400]
	Cont.	7 [9.4]	12,5 [17]	13 [17.4]	12,5 [17]	11,5 [15.4]	9 [12]	8 [10,7]	5 [6.7]	4,8 [6.4]
Max. Output, kW [HP]	Int.*	8,5 [11.4]	15 [20.1]	15 [20.1]	14,5 [19.5]	14 [18.8]	12 [16.1]	9,5 [12.7]	8 [10.7]	6,8 [9.1]
	Cont.	140 [2030]	175 [2540]	175 [2540]	175 [2540]	175 [2540]	140 [2030]	110 [1600]	85 [1230]	70 [1015]
	Peak**	225 [3260]	225 [3260]	225 [3260]	225 [3260]	225 [3260]	225 [3260]	200 [2900]	150 [2175]	115 [1670]
Max. Pressure Drop, bar [PSI]	Int.*	175 [2540]	200 [2900]	200 [2900]	200 [2900]	200 [2900]	175 [2540]	140 [2030]	115 [1670]	90 [1305]
	Cont.	40 [10.5]	60 [15.8]	60 [15.8]	60 [15.8]	60 [15.8]	60 [15.8]	60 [15.8]	60 [15.8]	60 [15.8]
	Peak**	50 [13.2]	75 [19.8]	75 [19.8]	75 [19.8]	75 [19.8]	75 [19.8]	75 [19.8]	75 [19.8]	75 [19.8]
Max. Oil Flow, lpm [GPM]	Int.*	10 [145]	10 [145]	10 [145]	9 [130]	7 [102]	5 [73]	4 [58]	3 [43.5]	3 [43.5]
Max. Starting Pressure with Unloaded Shaft, bar [PSI]		8 [710]	15 [1330]	20 [1770]	24 [2125]	32 [2830]	33 [2920]	31 [2740]	31,5 [2790]	31,5 [2790]
Min. Starting Torque, daNm [lb-in]	Cont.	175 [2540]	175 [2540]	175 [2540]	175 [2540]	175 [2540]	175 [2540]	175 [2540]	175 [2540]	175 [2540]
Max. Inlet Pressure, bar [PSI]	Int.*	200 [2900]	200 [2900]	200 [2900]	200 [2900]	200 [2900]	200 [2900]	200 [2900]	200 [2900]	200 [2900]
	Peak**	225 [3260]	225 [3260]	225 [3260]	225 [3260]	225 [3260]	225 [3260]	225 [3260]	225 [3260]	225 [3260]
	Cont.	7,2 [15.9]	7,5 [16.5]	7,7 [16.9]	8,0 [17.6]	8,3 [18.3]	8,6 [18.9]	9,1 [20.1]	9,8 [21.6]	10,1 [22.3]
Weight, kg [lb]										

* Intermittent operation: the permissible values may occur for max. 10% of every minute.

** Peak load: the permissible values may occur for max. 1% of every minute.

*** For speeds lower than given, consult factory or your regional manager.

1. Intermittent speed and intermittent pressure must not occur simultaneously.
2. Recommended filtration is per ISO cleanliness code 20/16. A nominal filtration of 25 micron or better.
3. Recommend using a premium quality, anti-wear type mineral based hydraulic oil HLP(DIN51524) or HM (ISO 6743/4).
If using synthetic fluids consult the factory for alternative seal materials.
4. Recommended minimum oil viscosity 13 mm²/s [70 SUS] at 50°C [122°F].
5. Recommended maximum system operating temperature is 82°C [180°F].
6. To assure optimum motor life fill with fluid prior to loading and run at moderate load and speed for 10-15 minutes.

SPECIFICATION DATA

Specification Data for SR... motors with K, CB, CA shafts.

Type		SR 50	SR 80	SR 100	SR 125	SR 160	SR 200	SR 250	SR 315	SR 400
Displacement, cm³/rev [in³/rev]		51,5 [3.14]	80,3 [4.90]	99,8 [6.09]	125,7 [7.67]	159,6 [9.74]	199,8 [12.19]	250,1 [15.26]	315,7 [19.26]	397 [24.4]
	Max. Speed, [RPM]									
	Cont.	775	750	600	475	375	300	240	190	150
	Int.*	970	940	750	600	470	375	300	240	190
Max. Torque, daNm [lb-in]	Cont.	10 [900]	20 [1770]	24 [2125]	30 [2655]	39 [3450]	45 [3980]	57 [5045]	57 [5045]	60 [3360]
	Int.*	13 [1150]	22 [1940]	28 [2480]	34 [3010]	43 [3805]	50 [4425]	61 [54000]	69 [6110]	69 [6110]
	Peak**	17 [1505]	27 [2390]	32 [2830]	37 [3275]	46 [4070]	56 [4960]	71 [6285]	84 [7435]	87 [8700]
Max. Output, kW [HP]	Cont.	7 [9.4]	12,5 [17]	13 [17.4]	12,5 [17]	11,5 [15.4]	11 [14.7]	10 [13.4]	9 [12]	7,8 [10.5]
	Int.*	8,5 [11.4]	15 [20.1]	15 [20.1]	14,5 [19.5]	14 [18.8]	13 [17.4]	12 [16.1]	10 [13.4]	10,6 [14.2]
Max. Pressure Drop, bar [PSI]	Cont.	140 [2030]	175 [2540]	175 [2540]	175 [2540]	175 [2540]	175 [2540]	175 [2540]	135 [1960]	110 [1600]
	Int.*	175 [2540]	200 [2900]	200 [2900]	200 [2900]	200 [2900]	200 [2900]	200 [2900]	175 [2540]	140 [2030]
	Peak**	225 [3260]	225 [3260]	225 [3260]	225 [3260]	225 [3260]	225 [3260]	225 [3260]	210 [3045]	175 [2540]
Max. Oil Flow, lpm [GPM]	Cont.	40 [10.5]	60 [15.8]	60 [15.8]	60 [15.8]	60 [15.8]	60 [15.8]	60 [15.8]	60 [15.8]	60 [15.8]
	Int.*	50 [13.2]	75 [19.8]	75 [19.8]	75 [19.8]	75 [19.8]	75 [19.8]	75 [19.8]	75 [19.8]	75 [19.8]
Max. Starting Pressure with Unloaded Shaft, bar [PSI]		10 [145]	10 [145]	10 [145]	9 [130]	7 [102]	5 [73]	4 [58]	3 [43.5]	3 [43.5]
Min. Starting Torque, daNm [lb-in]		8 [710]	15 [1330]	20 [1770]	24 [2125]	32 [2830]	41 [3630]	50 [4425]	50 [4425]	50 [4425]
Max. Inlet Pressure, bar [PSI]	Cont.	175 [2540]	175 [2540]	175 [2540]	175 [2540]	175 [2540]	175 [2540]	175 [2540]	175 [2540]	175 [2540]
	Int.*	200 [2900]	200 [2900]	200 [2900]	200 [2900]	200 [2900]	200 [2900]	200 [2900]	200 [2900]	200 [2900]
	Peak**	225 [3260]	225 [3260]	225 [3260]	225 [3260]	225 [3260]	225 [3260]	225 [3260]	225 [3260]	225 [3260]
Weight, kg [lb]		7,3 [16.1]	7,6 [16.8]	7,8 [16.9]	8,1 [17.9]	8,4 [18.5]	8,7 [19.2]	9,2 [20.3]	9,9 [21.8]	10,2 [22.5]

* Intermittent operation: the permissible values may occur for max. 10% of every minute.

** Peak load: the permissible values may occur for max. 1% of every minute.

*** For speeds lower than given, consult factory or your regional manager.

1. Intermittent speed and intermittent pressure must not occur simultaneously.
2. Recommended filtration is per ISO cleanliness code 20/16. A nominal filtration of 25 micron or better.
3. Recommend using a premium quality, anti-wear type mineral based hydraulic oil HLP(DIN51524) or HM (ISO 6743/4).
If using synthetic fluids consult the factory for alternative seal materials.
4. Recommended minimum oil viscosity 13 mm²/s [70 SUS] at 50°C [122°F].
5. Recommended maximum system operating temperature is 82°C [180°F].
6. To assure optimum motor life fill with fluid prior to loading and run at moderate load and speed for 10-15 minutes.

DIMENSIONS and MOUNTING DATA

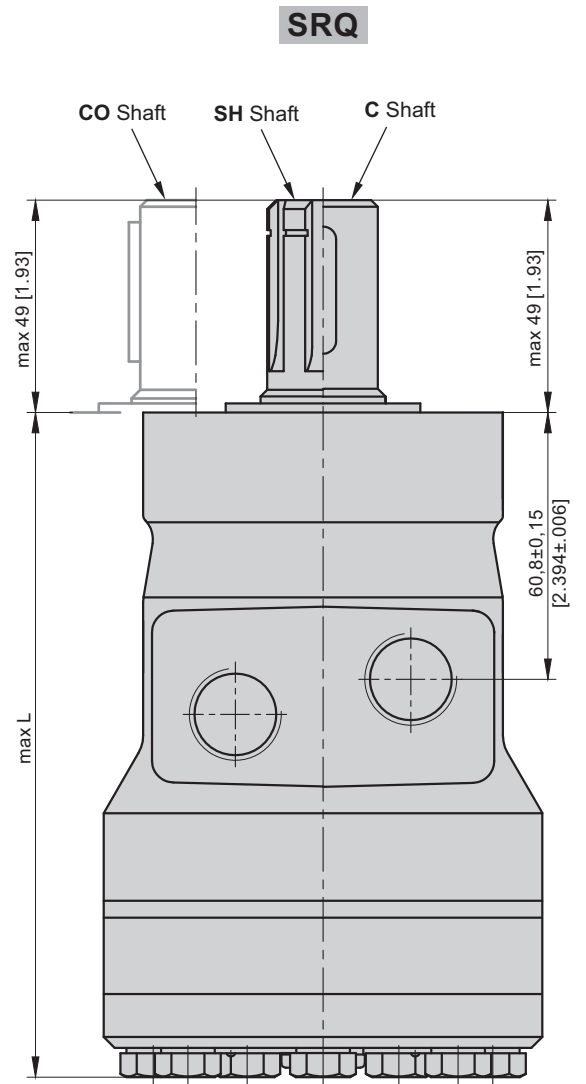
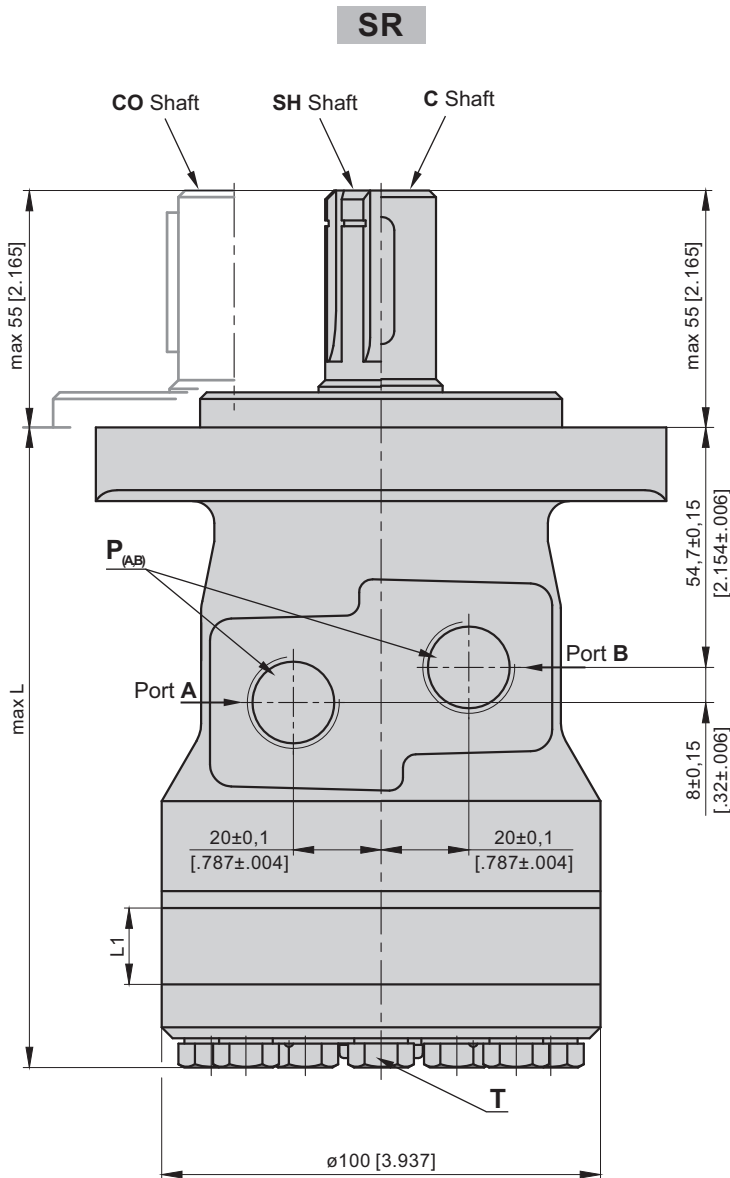

P_(A,B): 2xG1/2 - 18 mm [.709 in] depth
 T: G1/4 - 12 mm [.470 in] depth

Standard Rotation
 Viewed from Shaft End
 Port A Pressurized - **CW**
 Port B Pressurized - **CCW**

Reverse Rotation
 Viewed from Shaft End
 Port A Pressurized - **CCW**
 Port B Pressurized - **CW**

Type	L _{max} , mm [in]	Type	L _{max} , mm [in]	L ₁ , mm [in]
SR(F) 50	138 [5.43]	SRQ 50	144 [5.67]	9,0 [.35]
SR(F) 80	143 [5.63]	SRQ 80	149 [5.87]	14,0 [.55]
SR(F) 100	146,5 [5.77]	SRQ 100	152,6 [6.0]	17,4 [.69]
SR(F) 125	151 [5.94]	SRQ 125	157 [6.18]	21,8 [.89]
SR(F) 160	157 [6.18]	SRQ 160	163 [6.42]	27,8 [1.09]
SR(F) 200	164 [6.46]	SRQ 200	170 [6.69]	34,8 [1.37]
SR(F) 250	172,5 [6.79]	SRQ 250	178,5 [7.03]	43,5 [1.71]
SR(F) 315	184 [7.24]	SRQ 315	190 [7.48]	54,8 [2.16]
SR(F) 400	198,5 [7.81]	SRQ 400	205,5 [8.9]	69,4 [2.73]



DIMENSIONS and MOUNTING DATA

SRF

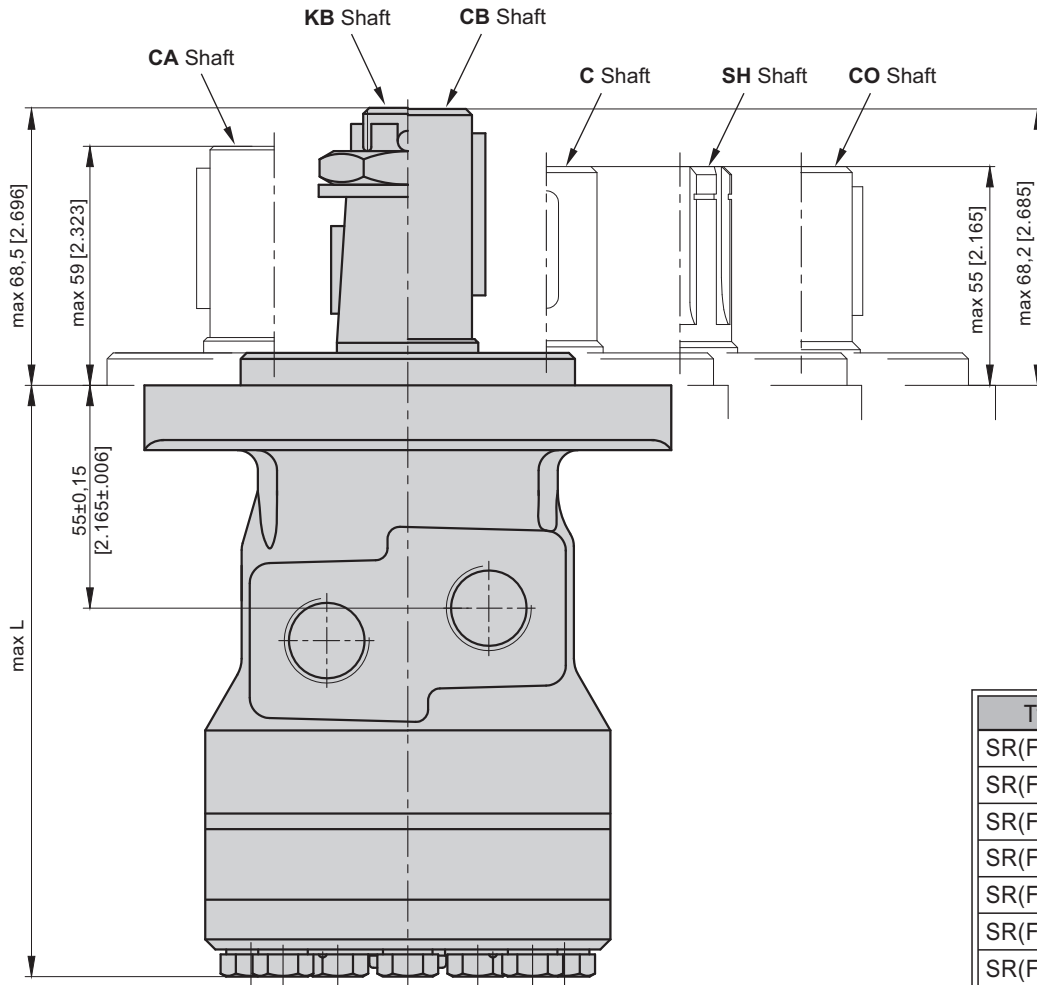

Type	L _{max} , mm [in]	L ₁ , mm [in]
SR(F) 50 T	157 [6.18]	9,0 [.35]
SR(F) 80 T	162 [6.38]	14,0 [.55]
SR(F) 100 T	166 [6.53]	17,4 [.69]
SR(F) 125 T	170 [6.69]	21,8 [.89]
SR(F) 160 T	176 [6.93]	27,8 [1.09]
SR(F) 200 T	183 [7.20]	34,8 [1.37]
SR(F) 250 T	191 [7.52]	43,5 [1.71]
SR(F) 315 T	203 [7.99]	54,8 [2.16]
SR(F) 400 T	217 [8.54]	69,4 [2.73]

SR(F)...T

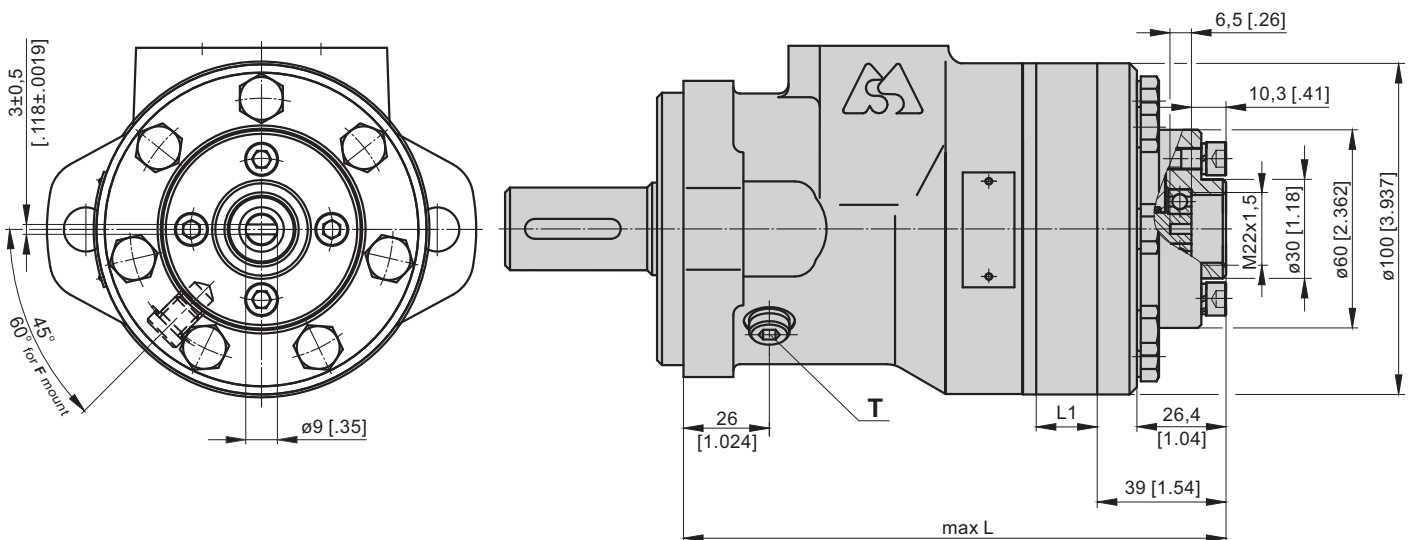

T : G1/8 - 10 mm [.39 in] depth for SR(F)...T

MOUNTING

Oval mount (2 Holes)

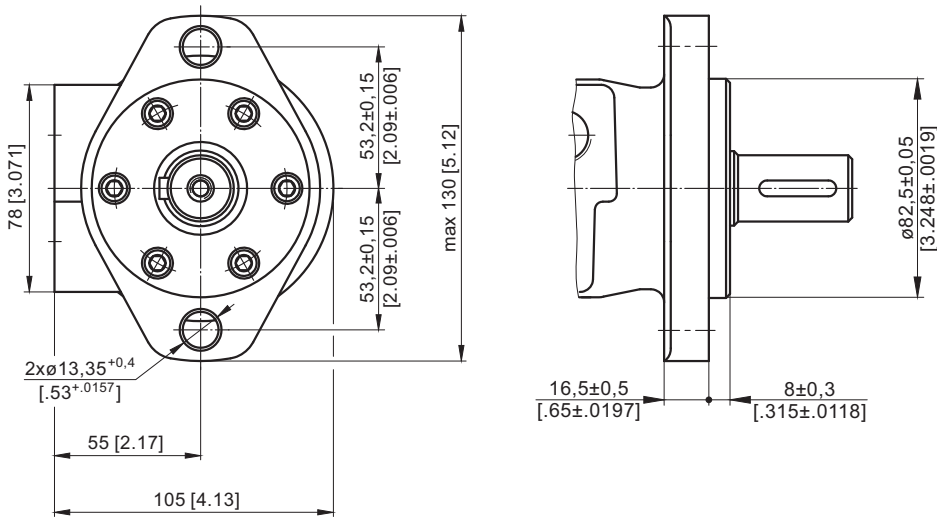

F Oval mount (6 holes)

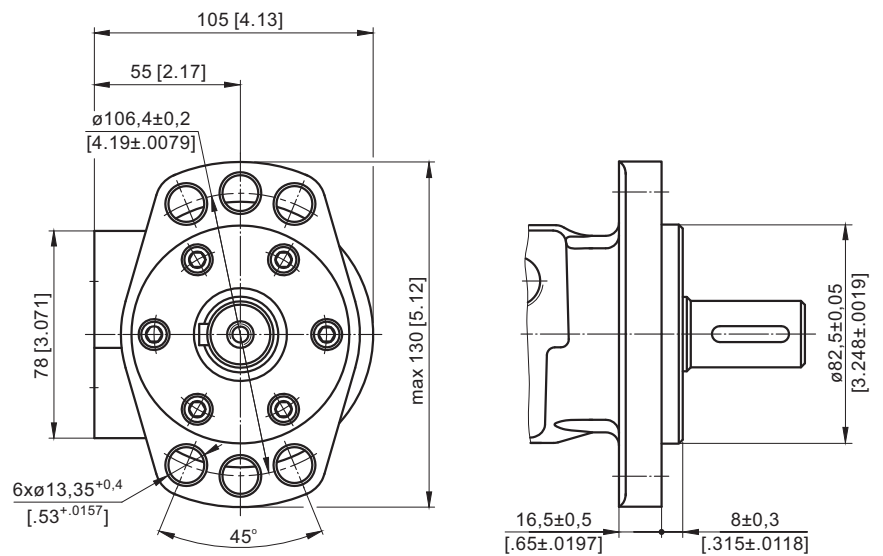

Q Square mount (4 bolts)

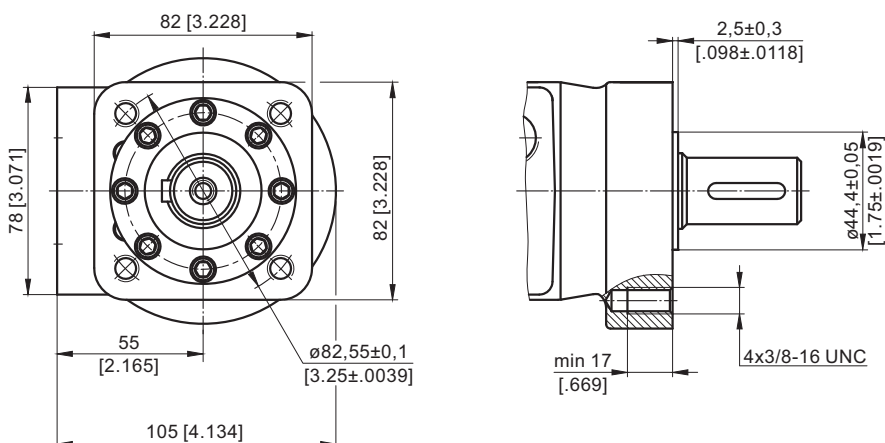

SHAFT EXTENSIONS

C - $\varnothing 25$ straight, Parallel key A8x7x30 DIN 6885
Max. Torque 34 daNm [3010 lb-in]

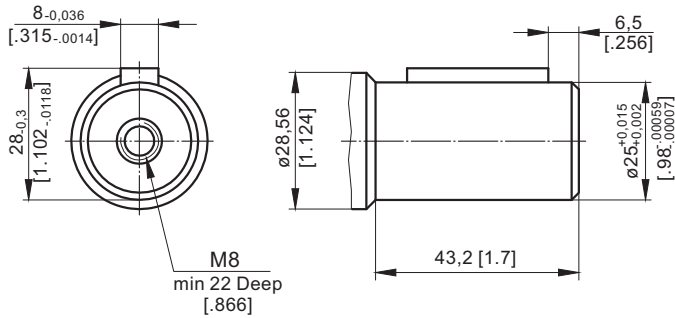

CO - $\varnothing 1$ " straight, Parallel key $\frac{1}{4} \times \frac{1}{4} \times 1 \frac{1}{4}$ " BS46
Max. Torque 34 daNm [3010 lb-in]

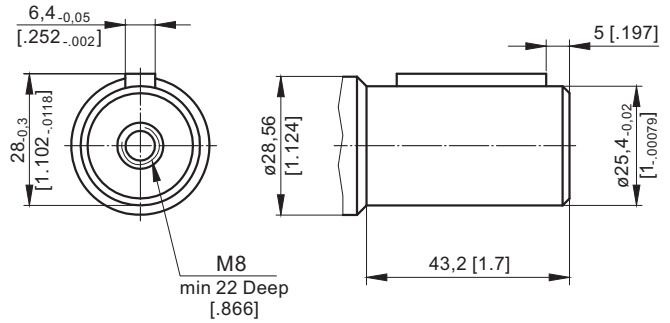

SH - splined, BS 2059 (SAE 6B)
Max. Torque 40 daNm [3540 lb-in]

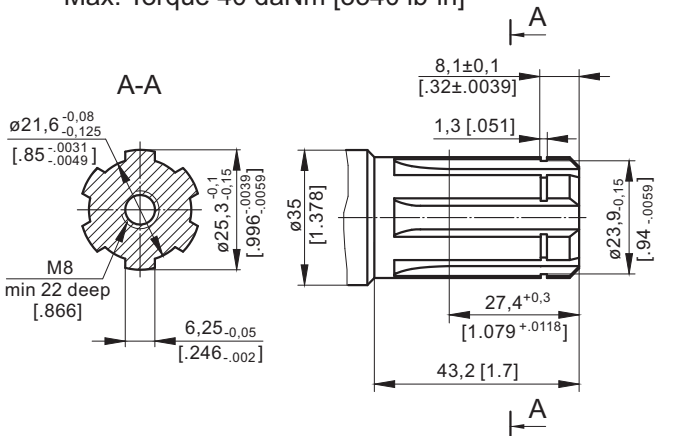

CB - $\varnothing 32$ straight, Parallel key 10x8x40 DIN 6885
Max. Torque 77 daNm [6815 lb-in]
(for F-flange only)

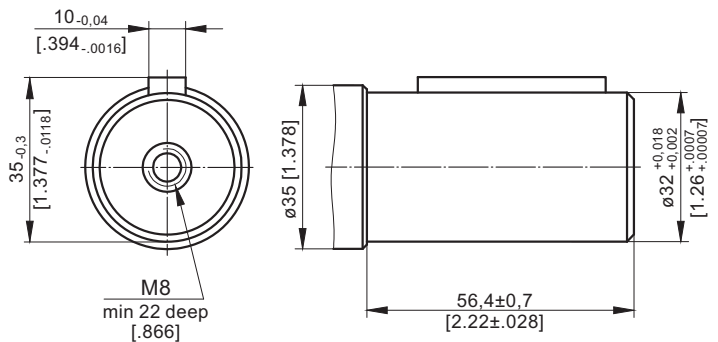

K - tapered 1:10, Woodruff key 6x9 DIN 6888
Max. Torque 95 daNm [8410 lb-in]
(for F-flange only)

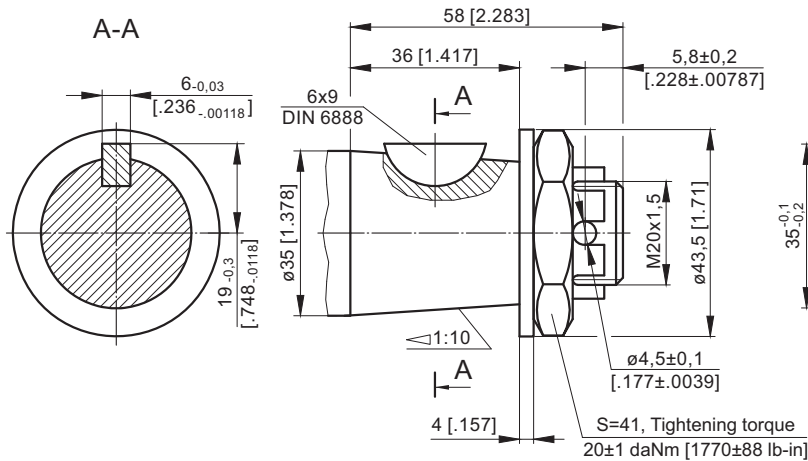

CA - $\varnothing 1 \frac{1}{4}$ " straight, Parallel key $\frac{5}{16} \times \frac{5}{16} \times 1 \frac{1}{4}$ " BS46
Max. Torque 77 daNm [6815 lb-in]
(for F-flange only)

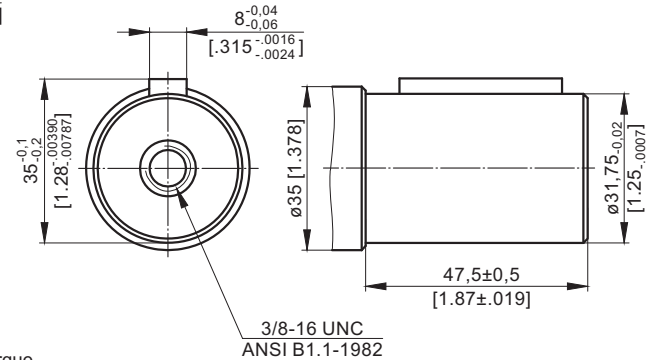

MAX. PERMISSIBLE SHAFT SEAL PRESSURE

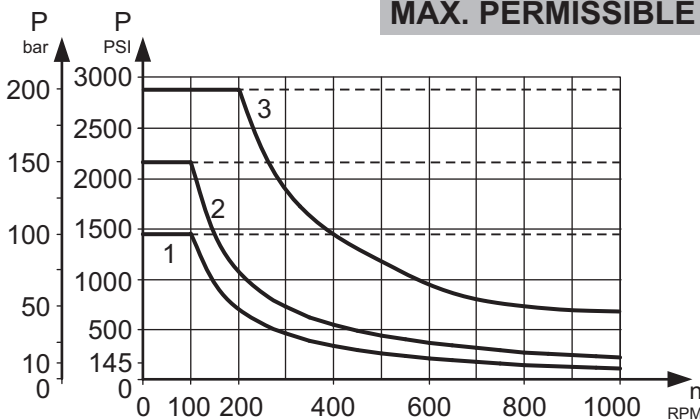

Max return pressure without drain line or max. pressure in drain line

— - continuous operations
- - - - intermittent operations

- 1: Curve for Standard Shaft Seal for **K**, **CA**, **CB** shafts
- 2: Curve for Standard Shaft Seal for **C**, **CO**, **SH** shafts
- 3: Curve for High Pressure Seal ("U" Seal) for **C**, **CO**, **SH** shafts. Not applicable for **K**, **CA** and **CB** shafts!



PERMISSIBLE SHAFT LOADS

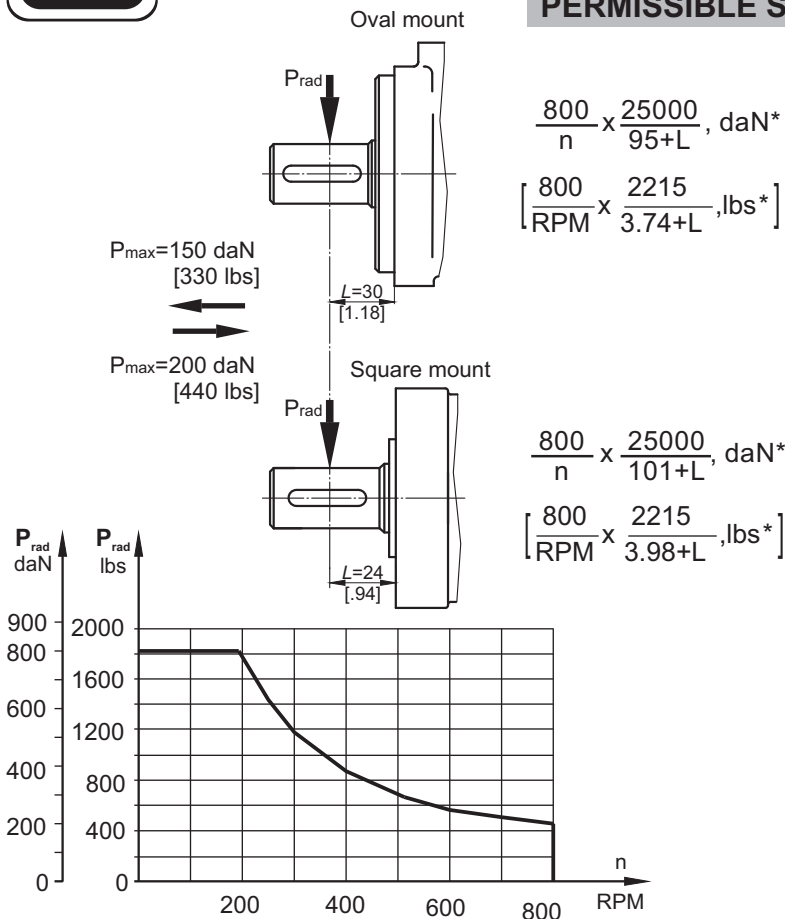

Radial Shaft Load P_{rad} for C, CO Shaft Extensions by $L=30 \text{ mm}$ [1.18 in] (24 mm [.94 in])

The permissible radial shaft load P_{rad} depends on the speed n , RPM, distance L from the point of load to the mounting flange and shaft version.

* $n \leq 200 \text{ RPM}$; max $P_{\text{rad}}=800 \text{ daN}$ [1800 lbs]
 $n \geq 200 \text{ RPM}$; $L < 55 \text{ mm}$ [2.2 in]

ORDER CODE

1	2	3	4	5	6	7
SR						

Pos.1 - Mounting Flange

- omit - Oval mount, two holes
- F** - Oval mount, six holes
- Q** - Square mount, four bolts - 3/8-16 UNC

Pos.2 - Displacement code**

- 50** - 51,5 cm³/rev [3.14 in³/rev]
- 80** - 80,3 cm³/rev [4.90 in³/rev]
- 100** - 99,8 cm³/rev [6.09 in³/rev]
- 125** - 125,7 cm³/rev [7.67 in³/rev]
- 160** - 159,6 cm³/rev [9.74 in³/rev]
- 200** - 199,8 cm³/rev [12.19 in³/rev]
- 250** - 250,1 cm³/rev [15.26 in³/rev]
- 315** - 315,7 cm³/rev [19.26 in³/rev]
- 400** - 397,0 cm³/rev [24.40 in³/rev]

Pos.3 - Shaft Extensions**

- C** - $\varnothing 25$ straight, Parallel key A8x7x30 DIN6885
- CO** - $\varnothing 1$ " straight, Parallel key $1/4$ "x $1/4$ "x $1/4$ " BS46
- SH** - $\varnothing 25,3$ splined, BS 2059 (SAE 6B)
- K*** - tapered 1:10, Woodruff key 6x9 DIN 6888
- CA*** - $\varnothing 1 1/4$ " straight, Parallel key $5/16$ "x $5/16$ "x $1/4$ " BS46
- CB*** - $\varnothing 32$ straight, Parallel key 10x8x40 DIN 6885

Pos.4 - Shaft Seal Version

- omit - Standard shaft seal
- U** - High pressure shaft seal (Not for **K, CA, CB** Shafts)

Pos.5 - Tacho Connection***

- omit - Without Tacho Connection
- T** - With Tacho Connection (Not for **Q** flange and **K, CA, CB** shafts)

Pos.6 - Additional Options (see page 125)

Pos.7 - Design Series

- omit - Factory specified

NOTES:

- * For "F"-flange only!
- ** The permissible output torque for shafts must not be exceeded!
- *** Radial or axial load on tacho shaft must be avoided. Max. torque on tacho shaft 0,1 daNm [.885 lb-in]. Max. cont. return pressure without drain line 20 bar [290 PSI].

For the Function Diagrams data please look at "M+S Hydraulic" Catalogue for MR motors, pages 35+39.

The hydraulic motors are manganese-phosphatized as standard.

HYDRAULIC MOTORS MRNA



APPLICATION

- » Actuator motor as driving-motor for steering mechanism of the three-wheel vehicles;
- » For conveyors (series connection);
- » Dosing motor etc.

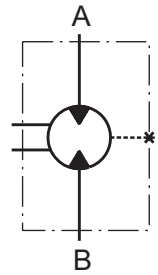

MRNA is suitable for driven mechanism where smooth operation low speed and high pressure is demanded. It is designed with separated output shaft and spool valve and can be specified with low internal leakage.

OPTIONS

- » Good start-up characteristics;
- » Precise control of the Torque at low small flow.
- » Smooth operation at high pressure and small oil flow;
- » High volumetric efficiency.

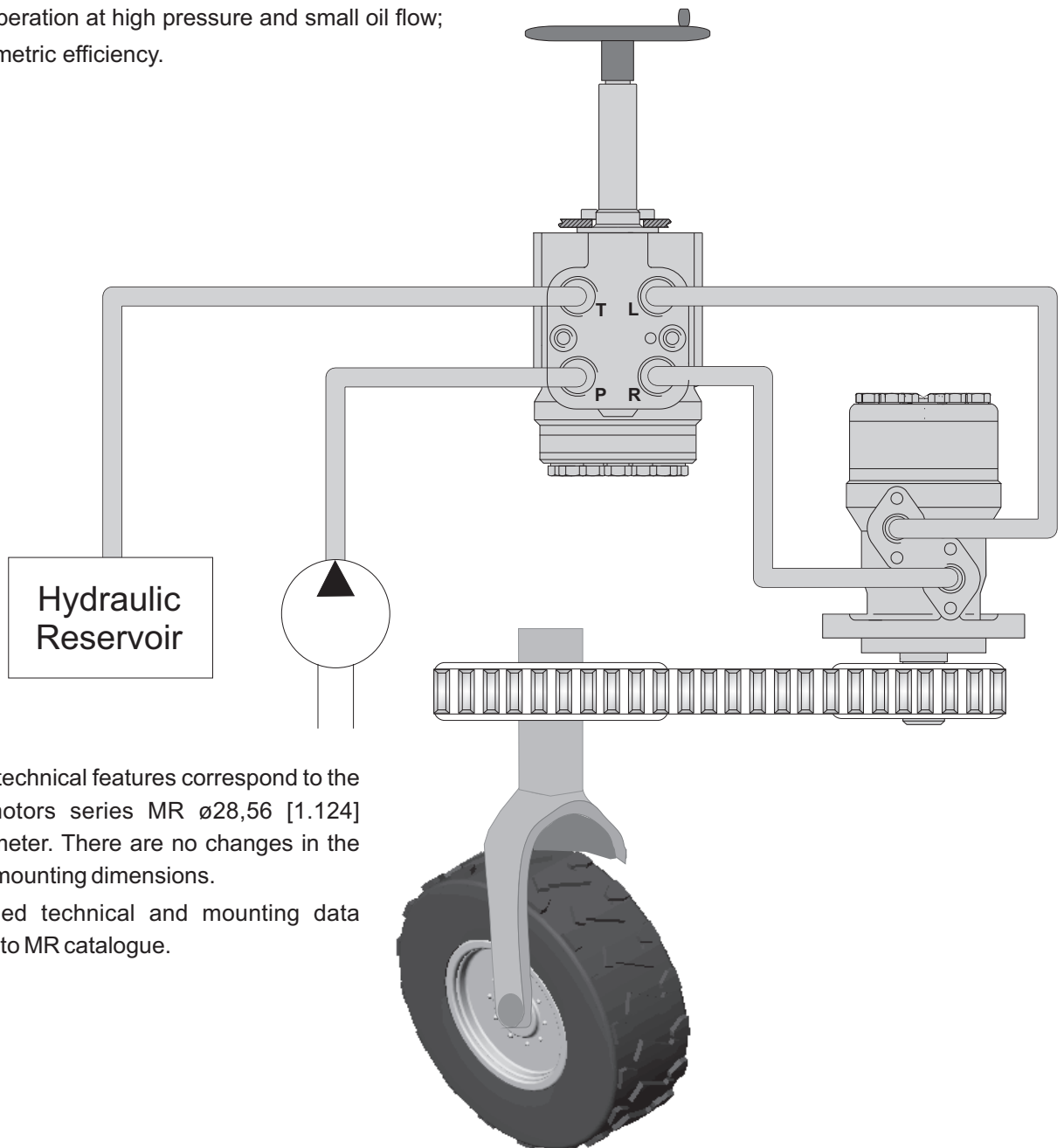

The main technical features correspond to the standard motors series MR $\varnothing 28,56$ [1.124] sealing diameter. There are no changes in the overall and mounting dimensions.

For detailed technical and mounting data please refer to MR catalogue.

SPECIFICATION DATA

Code	Displacement cm ³ /rev [in ³ /rev]	Max. Speed [RPM]	Max. Torque daNm [lb-in]				Max. Output kW [HP]				Max. Pressure Drop, bar [PSI]				Max. Oil Flow, lpm [GPM]
			C, CO shafts		SH, SA shafts		C, CO shafts		SH, SA shafts		C, CO shafts		SH, SA shafts		
			cont.	int*	cont.	int*	cont.	int*	cont.	int*	cont.	int*	cont.	int*	
MRNA 50	51,5 [3.14]	200	10 [885]	13 [1150]	10 [885]	13 [1150]	2,0 [2.68]	2,5 [3.35]	2,0 [2.68]	2,5 [3.35]	140 [2030]	175 [2540]	140 [2030]	175 [2540]	10,5 [2.8]
MRNA 80	80,3 [4.90]	200	20 [1770]	22 [1940]	20 [1770]	22 [1940]	3,0 [4.02]	3,5 [4.69]	3,0 [4.02]	3,5 [4.69]	175 [2540]	200 [2900]	175 [2540]	200 [2900]	16 [4.2]
MRNA 100	99,8 [6.09]	200	24 [2120]	28 [2480]	24 [2120]	28 [2480]	4,5 [6.03]	5,0 [6.71]	4,5 [6.03]	5,0 [6.71]	175 [2540]	200 [2900]	175 [2540]	200 [2900]	20 [5.3]
MRNA 125	125,7 [7.67]	200	30 [2650]	34 [3000]	30 [2650]	34 [3000]	5,5 [7.37]	6,0 [8.05]	5,5 [7.37]	6,0 [8.05]	175 [2540]	200 [2900]	175 [2540]	200 [2900]	25 [6.6]
MRNA 160	159,6 [9.74]	200	29 [2560]	39 [3450]	39 [3450]	43 [3800]	5,0 [6.71]	6,5 [8.05]	6,0 [8.05]	7,5 [10.05]	120 [1740]	175 [2540]	175 [2540]	200 [2900]	32 [8.5]
MRNA 200	199,8 [12.19]	200	29 [2560]	38,5 [3400]	38,5 [3400]	46 [4070]	5,0 [6.71]	7,0 [9.39]	6,5 [8.72]	9,0 [12.06]	105 [1520]	140 [2030]	140 [2030]	175 [2540]	40 [10.5]
MRNA 250	250,1 [15.26]	200	30 [2650]	39 [3450]	39 [3450]	47 [4160]	5,0 [6.71]	7,0 [9.39]	6,0 [8.05]	9,0 [12.06]	80 [1160]	110 [1600]	110 [1600]	140 [2030]	50 [13.2]
MRNA 315	315,7 [19.26]	190	30 [2650]	42 [3720]	36 [3450]	47 [4160]	5,0 [6.71]	7,5 [10.05]	6,0 [8.05]	8,5 [11.4]	70 [1020]	100 [1450]	85 [1230]	115 [1670]	65 [17.2]
MRNA 400	397,0 [24.4]	150	30 [2650]	40 [3540]	38 [3260]	47 [4160]	4,0 [5.36]	6,5 [8.72]	6,0 [8.05]	7,0 [9.39]	55 [800]	70 [1015]	65 [940]	90 [1300]	60 [15.8]

* Intermittent operation: the permissible values may occur for max. 10% of every minute.

ORDER CODE

1 2 3 4 5 6

MRNA

Pos.1 - Displacement code

- 50** - 51,5 cm³/rev [3.14 in³/rev]
- 80** - 80,3 cm³/rev [4.90 in³/rev]
- 100** - 99,8 cm³/rev [6.09 in³/rev]
- 125** - 125,7 cm³/rev [7.67 in³/rev]
- 160** - 159,6 cm³/rev [9.74 in³/rev]
- 200** - 199,8 cm³/rev [12.19 in³/rev]
- 250** - 250,1 cm³/rev [15.26 in³/rev]
- 315** - 315,7 cm³/rev [19.26 in³/rev]
- 400** - 397,0 cm³/rev [24.40 in³/rev]

Pos.2 - Shaft Extensions*

- C** - ø25 straight, Parallel key A8x7x30 DIN6885
- CO** - ø1" straight, Parallel key 1/4"x1/4"x1/4" BS46
- SH** - ø28,33 splined, BS 2059 (SAE 6B)
- K** - ø28,56 tapered 1:10, Parallel key B5x5x14 DIN 6888
- SA** - ø24,5 splined B25x22h9 DIN 5482

Pos.3 - Ports

- omit - BSPP (ISO 228)
- M** - Metric (ISO 262)

Pos.4 - Rotation

- omit - Standard Rotation
- R** - Reverse Rotation

Pos.5 - Additional Options (see page 125)

Pos.6 - Design Series

- omit - Factory specified

NOTES: * The permissible output torque for shafts must not be exceeded!
For the shaft dimensions please look at "M+S Hydraulic" catalogue for MR motors.

The hydraulic motors are manganophosphatized as standard.

HYDRAULIC MOTORS MRFL

APPLICATION

- » Actuator motor as driving-motor for steering mechanism of the three-wheel vehicles;
- » For conveyors (series connection);
- » Dosing motor etc.

OPTIONS

- » Good start-up characteristics;
- » Precise control of the Torque at low small flow.
- » Smooth operation at high pressure and small oil flow;
- » High volumetric efficiency.

The hydraulic motors type MRFL... are designed to be used in operating modes with peak radial loads of the output shaft (especially at starting and stopping) at direct drive of wheels or mechanisms (without clutch or gearbox).

The radial loads are borne by a radial ball bearing which is mounted on the shaft of the hydraulic motor.

The main technical features correspond to the standard motors series MRF $\varnothing 35$ mm [1.378 in] sealing diameter. There are no changes in the overall and mounting dimensions. For detailed technical and mounting data please refer to MR catalogue.

DIMENSIONS and MOUNTING DATA

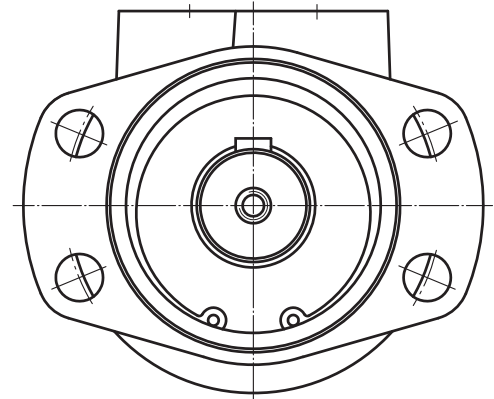
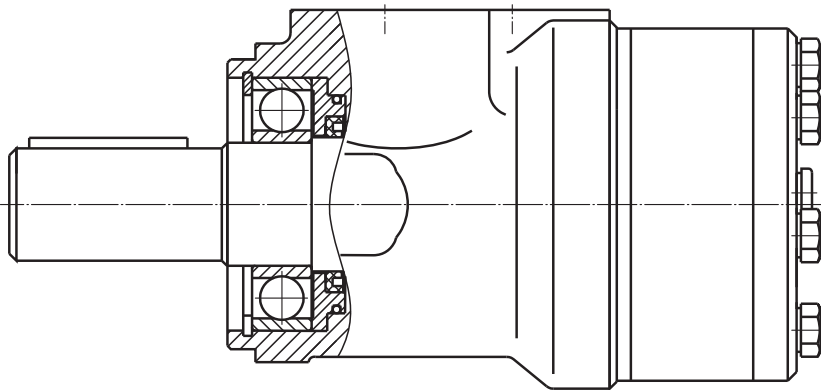

M 2:1

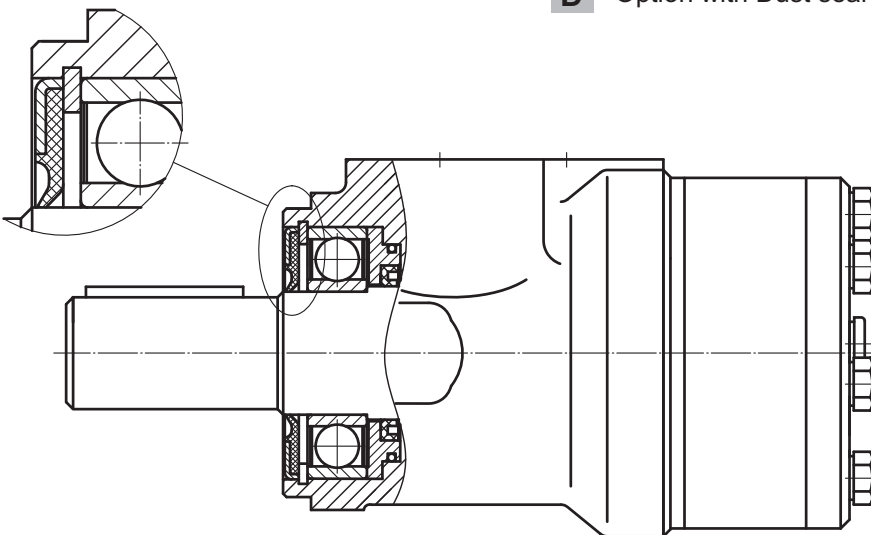

D - Option with Dust seal

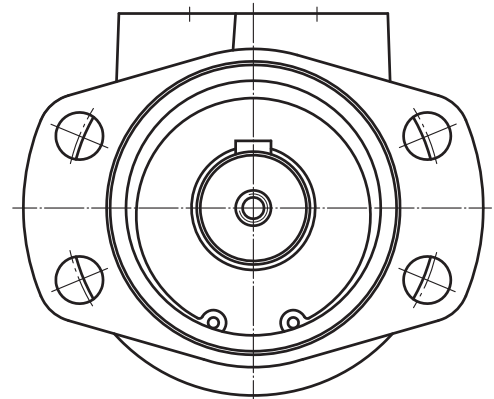

PERMISSIBLE SHAFT LOADS

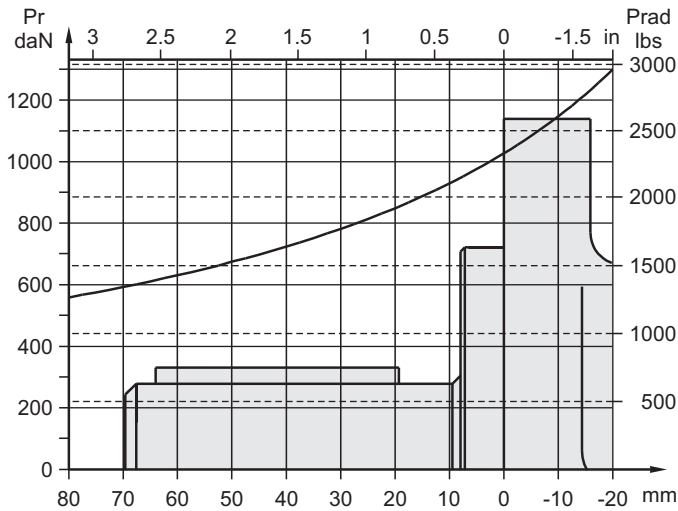

MAX. PERMISSIBLE SHAFT SEAL PRESSURE

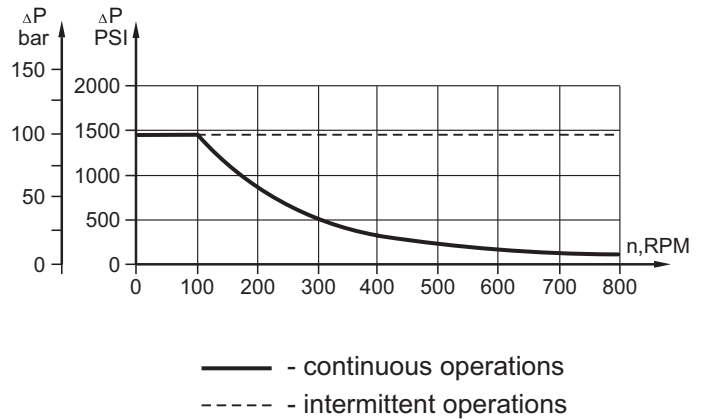

ORDER CODE

	1	2	3	4	5	6	7	8	9	10
M R										

Pos.1 - Mounting Flange

F - Oval mount, four holes

Pos.2 - Option (bearings)

L - with radial ball bearing

Pos.3 - Port type

omit - Side ports

E - Rear ports

Pos.4 - Displacement code

- 50** - 51,5 cm³/rev [3.14 in³/rev]
- 80** - 80,3 cm³/rev [4.90 in³/rev]
- 100** - 99,8 cm³/rev [6.09 in³/rev]
- 125** - 125,7 cm³/rev [7.67 in³/rev]
- 160** - 159,6 cm³/rev [9.74 in³/rev]
- 200** - 199,8 cm³/rev [12.19 in³/rev]
- 250** - 250,1 cm³/rev [15.26 in³/rev]
- 315** - 315,7 cm³/rev [19.26 in³/rev]
- 400** - 397,0 cm³/rev [24.40 in³/rev]

Pos. 5 - Shaft Extensions

- CB** - ø32 straight, Parallel key A10x8x45 DIN6885
- KB** - ø35 tapered 1:10, Parallel key B6x6x20 DIN6885
- SB** - splined A 25x22 DIN 5482
- OB** - ø1¼" tapered 1:8, Parallel key ⁵/₁₆"x⁵/₁₆"x1¼" BS46
- HB** - ø1¼" splined 14T ANSI B92.1 - 1976

Pos. 6 - Option (Dust Seal)

omit - without dust seal

D - with dust seal

Pos. 7 - Drain Port

omit - with drain port

1 - without drain port

Pos. 8 - Ports

omit - BSPP (ISO 228)

M - Metric (ISO 262)

Pos. 9 - Additional Options (see page 125)

Pos.10 - Design Series

omit - Factory specified

NOTES: * The permissible output torque for shafts must not be exceeded!

The hydraulic motors are manganophosphatized as standard.

HYDRAULIC MOTORS with Dual shaft MRB

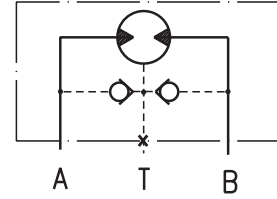
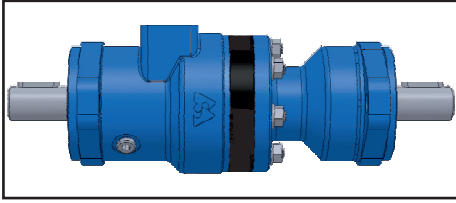

APPLICATION

- » Conveyors;
- » Feeding mechanism of robots and manipulators;
- » Metal working machines;
- » Textile machines;
- » Agricultural machines;
- » Food industries;
- » Mining machinery etc.

OPTIONS

- » Model - Spool valve, roll-gerotor;
- » Dual shaft;
- » Oval flange;
- » Side port;
- » Straight shafts;
- » BSPP ports;
- » Other special features.

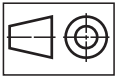

mm [in]

OUTLINE DIMENSIONS REFERENCE

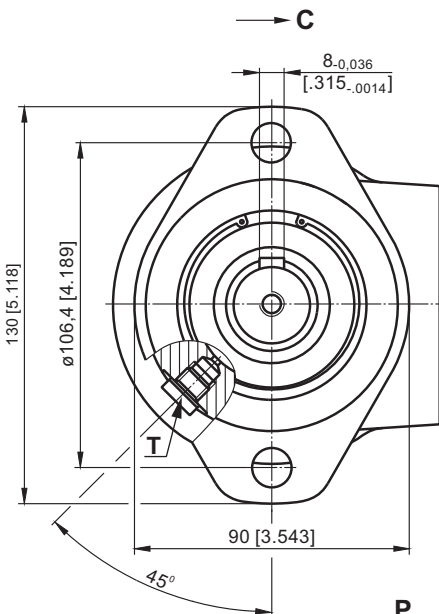
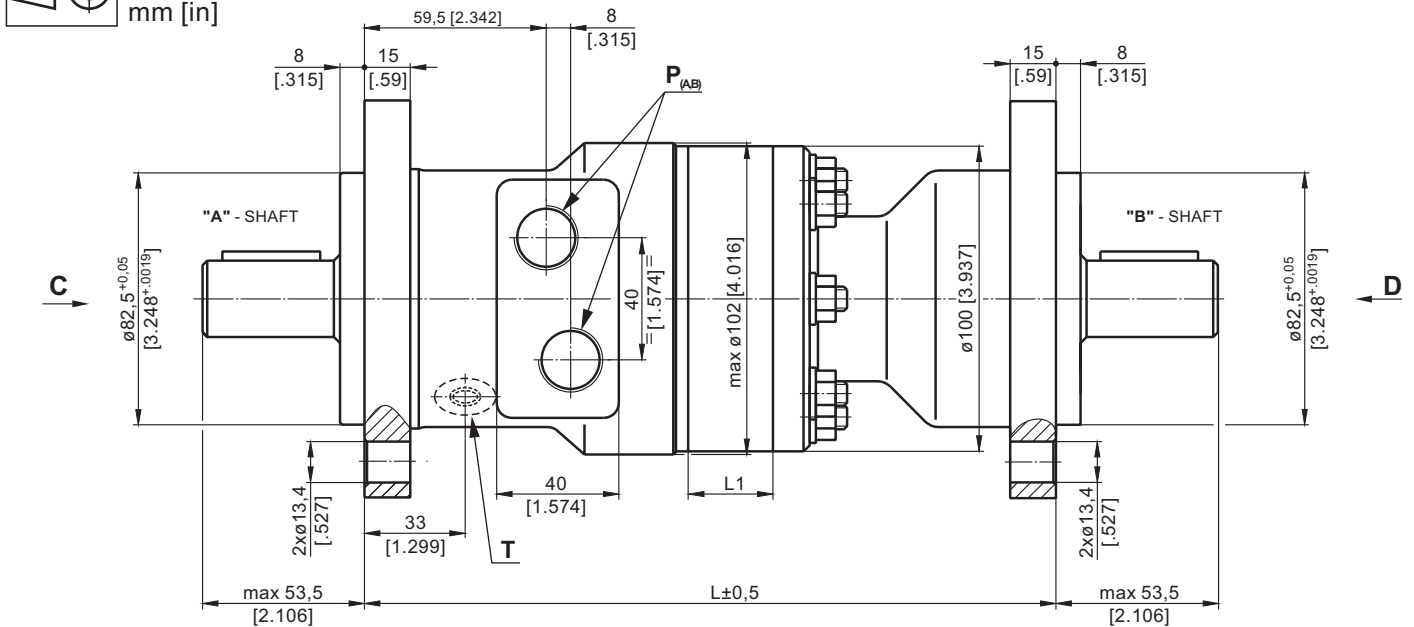

Type	L, mm [in]	L1, mm[in]
MRB 50	211,7 [8.33]	9,0 [.35]
MRB 80	216,7 [8.53]	14,0 [.55]
MRB 100	216,1 [8.51]	17,4 [.69]
MRB 125	220,5 [8.68]	21,8 [.86]
MRB 160	226,5 [8.92]	27,8 [1.09]
MRB 200	233,5 [9.19]	34,8 [1.37]
MRB 250	242,2 [9.54]	43,5 [1.71]
MRB 315	253,5 [9.98]	54,8 [2.16]
MRB 400	268,1 [10.56]	69,4 [2.73]

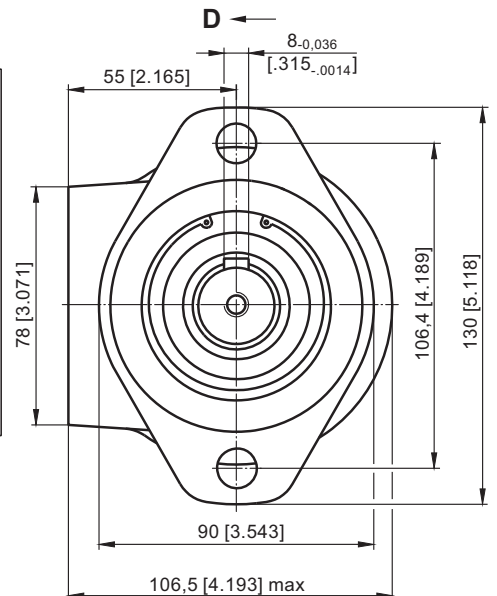

P_(A,B) : 2xG1/2 - 18 mm [.71 in] depth
T : G1/8 - 9 mm [.35 in] depth (plugged)

SPECIFICATION DATA

Type		MRB 50 C/C	MRB 80 C/C	MRB 100 C/C	MRB 125 C/C	MRB 160 C/C	MRB 200 C/C	MRB 250 C/C	MRB 315 C/C	MRB 400 C/C
Displacement, cm³/rev [in³/rev]		51,5	80,3	99,8	125,7	159,6	199,8	250,1	315,7	397
		[3.14]	[4.9]	[6.1]	[7.7]	[9.7]	[12.2]	[15.3]	[19.3]	[24.4]
Max. Speed, [RPM]	Cont.	775	750	600	475	375	300	240	190	150
	Int.*	970	940	750	600	470	375	300	240	190
Max. Torque, daNm [lb-in]	Cont.	10 [885]	19,5 [1725]	24 [2125]	30 [2655]	30 [2655]	30 [2655]	30 [2655]	30 [2655]	30 [2655]
	Int.*	13 [1150]	22 [1945]	28 [2480]	34 [3010]	39 [3450]	39 [3450]	38 [3360]	42 [3720]	43 [3805]
Max. Torque "A" shaft, daNm [lb-in]	Cont.	8 [710]	11,5 [1000]	12 [1060]	20 [1770]	20 [1770]	20 [1770]	20 [1770]	20 [1770]	20 [1770]
	Int.*	9,5 [840]	13 [1150]	14 [1240]	23 [2035]	23 [2035]	23 [2035]	23 [2035]	23 [2035]	23 [2035]
Max. Torque "B" shaft, daNm [lb-in]	Cont.	4 [355]	11,5 [1000]	12 [1060]	20 [1770]	20 [1770]	20 [1770]	20 [1770]	20 [1770]	20 [1770]
	Int.*	5 [440]	13 [1150]	14 [1240]	23 [2035]	23 [2035]	23 [2035]	23 [2035]	23 [2035]	23 [2035]
Max. Output, kW [HP]	Cont.	7 [9.5]	12,5 [17]	13 [17.4]	12,5 [17]	10 [13.4]	8 [10.7]	6 [8.0]	5 [6.7]	4 [5.4]
	Int.*	8,5 [11.9]	15 [20.1]	15 [20.1]	14,5 [19.4]	12,5 [17]	10 [13.4]	8 [10.7]	6,5 [8.7]	6 [8.0]
Max. Pressure Drop, bar [PSI]	Cont.	140 [2030]	175 [2540]	175 [2540]	175 [2540]	130 [1885]	110 [1600]	80 [1160]	70 [1020]	55 [800]
	Int.*	175 [2540]	200 [2900]	200 [2900]	200 [2900]	175 [2540]	140 [2030]	110 [1600]	100 [1450]	80 [1160]
Max. Oil Flow, lpm [GPM]	Cont.	40 [10.5]	60 [15.9]	60 [15.9]	60 [15.9]	60 [15.9]	60 [15.9]	60 [15.9]	60 [15.9]	60 [15.9]
	Int.*	50 [13.2]	75 [18.5]	75 [18.5]	75 [18.5]	75 [18.5]	75 [18.5]	75 [18.5]	75 [18.5]	75 [18.5]
Max. Return Pressure without Drain Line, bar [PSI]	Cont. 0-100 RPM	75 [1090]	75 [1090]	75 [1090]	75 [1090]	75 [1090]	75 [1090]	75 [1090]	75 [1090]	75 [1090]
	Cont. 100-200 RPM	50 [730]	50 [730]	50 [730]	50 [730]	50 [730]	50 [730]	50 [730]	50 [730]	50 [730]
	Cont. 200-500 RPM	20 [290]	20 [290]	20 [290]	20 [290]	20 [290]	20 [290]	20 [290]	20 [290]	20 [290]
	Int.* 0-max RPM	75 [1090]	75 [1090]	75 [1090]	75 [1090]	75 [1090]	75 [1090]	75 [1090]	75 [1090]	75 [1090]

* Intermittent operation: the permissible values may occur for max. 10% of every minute.

1. Intermittent speed and intermittent pressure must not occur simultaneously.
2. Recommended filtration is per ISO cleanliness code 20/16. A nominal filtration of 25 micron or better.
3. Recommend using a premium quality, anti-wear type mineral based hydraulic oil HLP(DIN51524) or HM (ISO 6743/4).
If using synthetic fluids consult the factory for alternative seal materials.
4. Recommended minimum oil viscosity 13 mm²/s [70 SUS] at 50°C [122°F].
5. Recommended maximum system operating temperature is 82°C [180°F].
6. To assure optimum motor life fill with fluid prior to loading and run at moderate load and speed for 10-15 minutes.

SHAFT EXTENSIONS

C - $\varnothing 25$ straight, Parallel key A8x7x30 DIN 6885
Max. Torque 34 daNm [3010 lb-in]

SH - 1" splined, BS 2059 (SAE 6B)
Max. Torque 40 daNm [3540 lb-in]

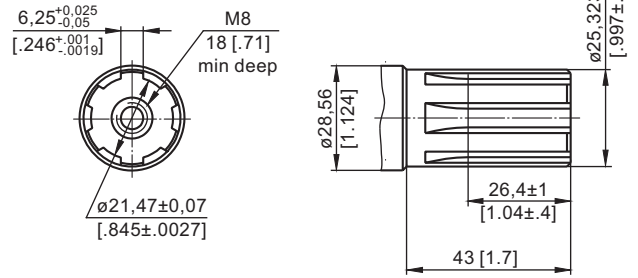
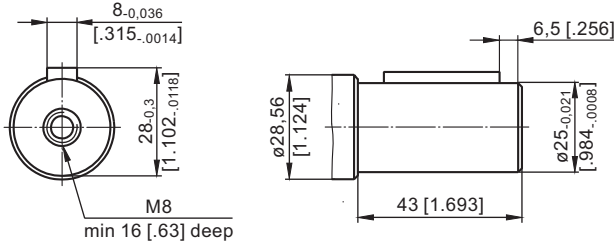

PERMISSIBLE SHAFT LOADS

The load diagrams are valid for an average bearings life of 1600 hrs at 200 r.p.m. with mineral base lubricating containing antiwear additives (ref.ISO 281 (3.3) standard).
The "A" curve gives the maximum static load affordable by the bearings.
The "B" curve gives the radial load top limit without axial load of 200 daNm.

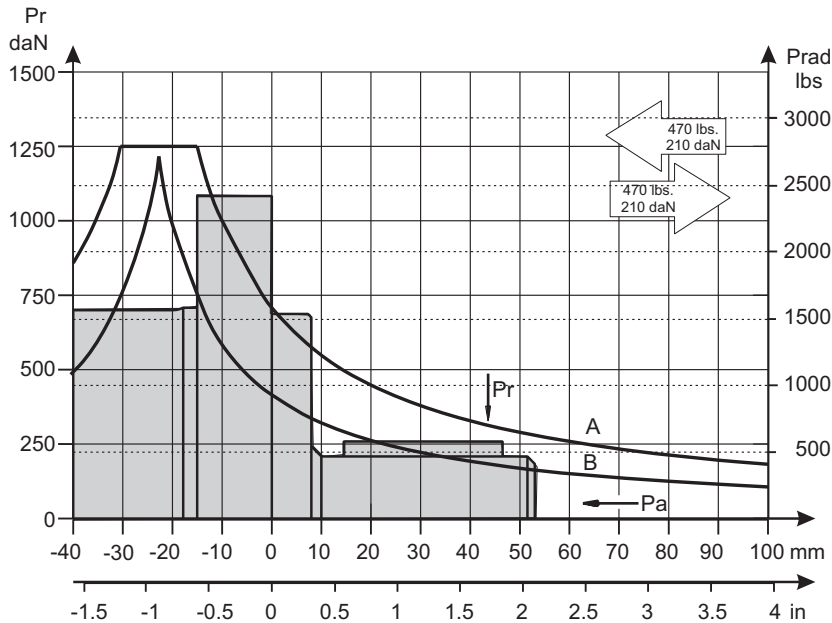

ORDER CODE

1	2	3	4	5
MRB		/		

Pos.1 - Displacement code

50	- 51,5 cm ³ /rev [3.14 in ³ /rev]
80	- 80,3 cm ³ /rev [4.90 in ³ /rev]
100	- 99,8 cm ³ /rev [6.09 in ³ /rev]
125	- 125,7 cm ³ /rev [7.67 in ³ /rev]
160	- 159,6 cm ³ /rev [9.74 in ³ /rev]
200	- 199,8 cm ³ /rev [12.19 in ³ /rev]
250	- 250,1 cm ³ /rev [15.26 in ³ /rev]
315	- 315,7 cm ³ /rev [19.26 in ³ /rev]
400	- 397,0 cm ³ /rev [24.40 in ³ /rev]

Pos.2 - "A" Shaft Extensions*

C	- $\varnothing 25$ straight, Parallel key A8x7x30 DIN6885
SH	- 1" splined, BS 2059 (SAE 6B)

Pos.3 - "B" Shaft Extensions*

C	- $\varnothing 25$ straight, Parallel key A8x7x30 DIN6885
SH	- 1" splined, BS 2059 (SAE 6B)

Pos.4 - Additional Options (see page 125)

Pos.5 - Design Series

omit - Factory specified

NOTES: * For other shaft extensions please contact with "M+S Hydraulic".
** Color at customer's request.

The hydraulic motors are manganophosphatized as standard.

HYDRAULIC MOTORS PL

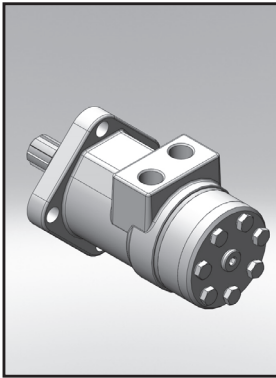

APPLICATION

- » Conveyors
- » Feeding mechanism of robots and manipulators
- » Metal working machines
- » Textile machines
- » Agricultural machines
- » Food industries
- » Mining machinery etc.

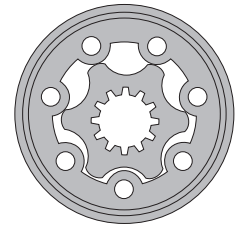
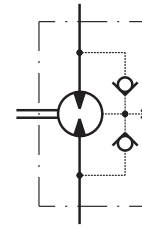

CONTENTS

Specification data	67
Dimensions and mounting	68
Shaft extensions	69
Permissible shaft loads	70
Order code	70

OPTIONS

- » Model - Spool valve, gerotor
- » Antifriction needle bearing
- » Flange mount
- » Shafts - straight, splined and tapered
- » Metric and BSPP ports
- » Other special features

GENERAL

Max. Displacement, cm ³ /rev [in ³ /rev]	396 [24.16]
Max. Speed, [RPM]	1515
Max. Torque, daNm [lb-in]	cont.: 50 [4415] int.: 59 [5222]
Max. Output, kW [HP]	17,5 [23.5]
Max. Pressure Drop, bar [PSI]	cont.: 140 [2030] int.: 175 [2540]
Max. Oil Flow, lpm [GPM]	75 [19.8]
Min. Speed, [RPM]	10
Pressure fluid	Mineral based- HLP(DIN 51524) or HM(ISO 6743/4)
Temperature range, °C [°F]	-40÷140 [-40÷284]
Optimal Viscosity range, mm ² /s [SUS]	20÷75 [98÷347]
Filtration	ISO code: 18/16/13 According to ISO 4406-1999

Oil flow in drain line

Pressure drop bar [PSI]	Viscosity mm ² /s [SUS]	Oil flow in drain line lpm [GPM]
100 [1450]	20 [98]	2,5 [.660]
	35 [164]	1,8 [.476]
140 [2030]	20 [98]	3,5 [.925]
	35 [164]	2,8 [.740]

Pressure Losses

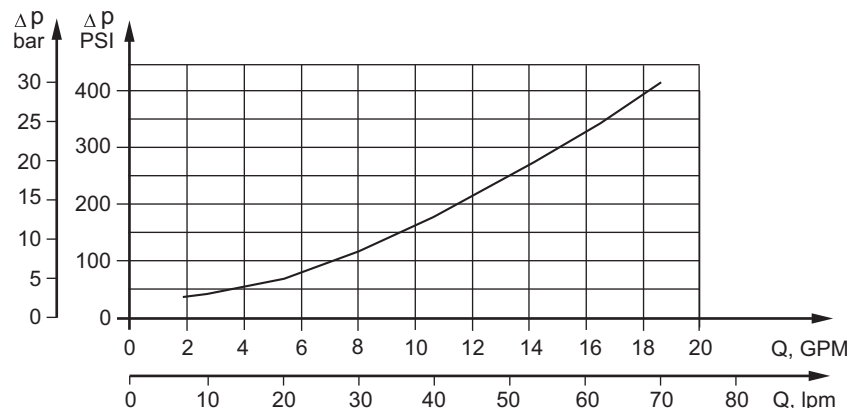

SPECIFICATION DATA

Type		PL 50	PL 80	PL 100	PL 125	PL 160	PL 200	PL 250	PL 315	PL 400
Displacement, cm³/rev [in³/rev]		49,5 [3.02]	79,2 [4.83]	99 [6.04]	123,8 [7.55]	158,4 [9.66]	198 [12.1]	247,5 [15.1]	316,8 [19.3]	396 [24.16]
Max. Speed, [RPM]	Cont.	1210	755	605	485	378	303	242	190	150
	Int.*	1515	945	755	605	472	378	303	236	189
Max. Torque, daNm [lb-in]	Cont.	9,4 [832]	15,1 [1336]	19,3 [1708]	23,7 [2100]	31,3 [2770]	36,6 [3240]	47 [4160]	48,6 [4300]	50 [4425]
	Int.*	11,9 [1054]	19,5 [1725]	23,7 [2097]	29,8 [2637]	37,8 [3345]	45,6 [4035]	58,3 [5160]	56 [4956]	59 [5222]
	Peak**	14,0 [1240]	22,0 [1947]	27,0 [2390]	36,5 [3230]	42 [3717]	53 [4700]	67 [5930]	85 [7523]	85,4 [7560]
Max. Output, kW [HP]	Cont.	9,9 [13.3]	9,9 [13.3]	9,9 [13.3]	9,9 [13.3]	11,7 [15.7]	10,3 [13.8]	9,8 [13.1]	7,6 [10.2]	6,6 [8.9]
	Int.*	12,5 [16.8]	12,5 [16.8]	12,5 [16.8]	12,5 [16.8]	12,5 [16.8]	12,5 [16.8]	12,5 [16.8]	10,5 [14]	8,5 [11.4]
Max. Pressure Drop, bar [PSI]	Cont.	140 [2030]	140 [2030]	140 [2030]	140 [2030]	140 [2030]	140 [2030]	140 [2030]	120 [1300]	95 [1015]
	Int.*	175 [2540]	175 [2540]	175 [2540]	175 [2540]	175 [2540]	175 [2540]	175 [2540]	140 [2030]	115 [1665]
	Peak**	225 [3260]	225 [3260]	225 [3260]	225 [3260]	225 [3260]	225 [3260]	225 [3260]	225 [3260]	180 [2610]
Max. Oil Flow, lpm [GPM]	Cont.	60 [16]	60 [16]	60 [16]	60 [16]	60 [16]	60 [16]	60 [16]	60 [16]	60 [16]
	Int.*	75 [20]	75 [20]	75 [20]	75 [20]	75 [20]	75 [20]	75 [20]	75 [20]	75 [20]
Max. Inlet Pressure, bar [PSI]	Cont.	175 [2540]	175 [2540]	175 [2540]	175 [2540]	175 [2540]	175 [2540]	175 [2540]	175 [2540]	175 [2540]
	Int.*	200 [2900]	200 [2900]	200 [2900]	200 [2900]	200 [2900]	200 [2900]	200 [2900]	200 [2900]	200 [2900]
	Peak**	225 [3260]	225 [3260]	225 [3260]	225 [3260]	225 [3260]	225 [3260]	225 [3260]	225 [3260]	225 [3260]
Max. Return Pressure without Drain Line or Max. Pressure in Drain Line, bar [PSI]	Cont. 0-100 RPM	100 [1450]	100 [1450]	100 [1450]	100 [1450]	100 [1450]	100 [1450]	100 [1450]	100 [1450]	100 [1450]
	Cont. 100-300 RPM	50 [725]	50 [725]	50 [725]	50 [725]	50 [725]	50 [725]	50 [725]	50 [725]	50 [725]
	Cont. 300-600 RPM	25 [365]	25 [365]	25 [365]	25 [365]	25 [365]	25 [365]	25 [365]	25 [365]	25 [365]
	Cont. >600 RPM	15 [220]	15 [220]	15 [220]	15 [220]	15 [220]	15 [220]	15 [220]	15 [220]	15 [220]
	Int.* 0-max RPM	100 [1450]	100 [1450]	100 [1450]	100 [1450]	100 [1450]	100 [1450]	100 [1450]	100 [1450]	100 [1450]
Max. Return Pressure with Drain Line, bar [PSI]	Cont.	175 [2540]	175 [2540]	175 [2540]	175 [2540]	175 [2540]	175 [2540]	175 [2540]	175 [2540]	175 [2540]
	Int.*	200 [2900]	200 [2900]	200 [2900]	200 [2900]	200 [2900]	200 [2900]	200 [2900]	200 [2900]	200 [2900]
	Peak**	225 [3260]	225 [3260]	225 [3260]	225 [3260]	225 [3260]	225 [3260]	225 [3260]	225 [3260]	225 [3260]
Max. Starting Pressure with Unloaded Shaft, bar [PSI]		10 [145]	10 [145]	10 [145]	9 [131]	8 [116]	7 [100]	6 [87]	5 [73]	5 [73]
Min. Starting Torque, daNm [lb-in]		7,7 [681]	13 [1150]	16,8 [1487]	21,0 [1860]	28,0 [2478]	32,2 [2850]	41,4 [3665]	43,0 [3805]	44,0 [3900]
Min. Speed***, [RPM]		10	10	10	10	10	10	10	10	10
Weight, kg [lb]		6,8 [15]	7,0 [15.4]	7,1 [15.7]	7,2 [15.9]	7,4 [16.3]	7,6 [16.8]	7,8 [17.2]	8,2 [18]	8,6 [18.9]

* Intermittent operation: the permissible values may occur for max. 10% of every minute.

** Peak load: the permissible values may occur for max. 1% of every minute.

*** For speeds lower than given, consult factory or your regional manager.

- Intermittent speed and intermittent pressure must not occur simultaneously.
- Recommended filtration is per ISO cleanliness code 20/16. A nominal filtration of 25 micron or better.
- Recommend using a premium quality, anti-wear type mineral based hydraulic oil HLP(DIN51524) or HM (ISO 6743/4).
If using synthetic fluids consult the factory for alternative seal materials.
- Recommended minimum oil viscosity 13 mm²/s [70 SUS] at 50°C [122°F].
- Recommended maximum system operating temperature is 82°C [180°F].
- To assure optimum motor life fill with fluid prior to loading and run at moderate load and speed for 10-15 minutes.

DIMENSIONS and MOUNTING DATA

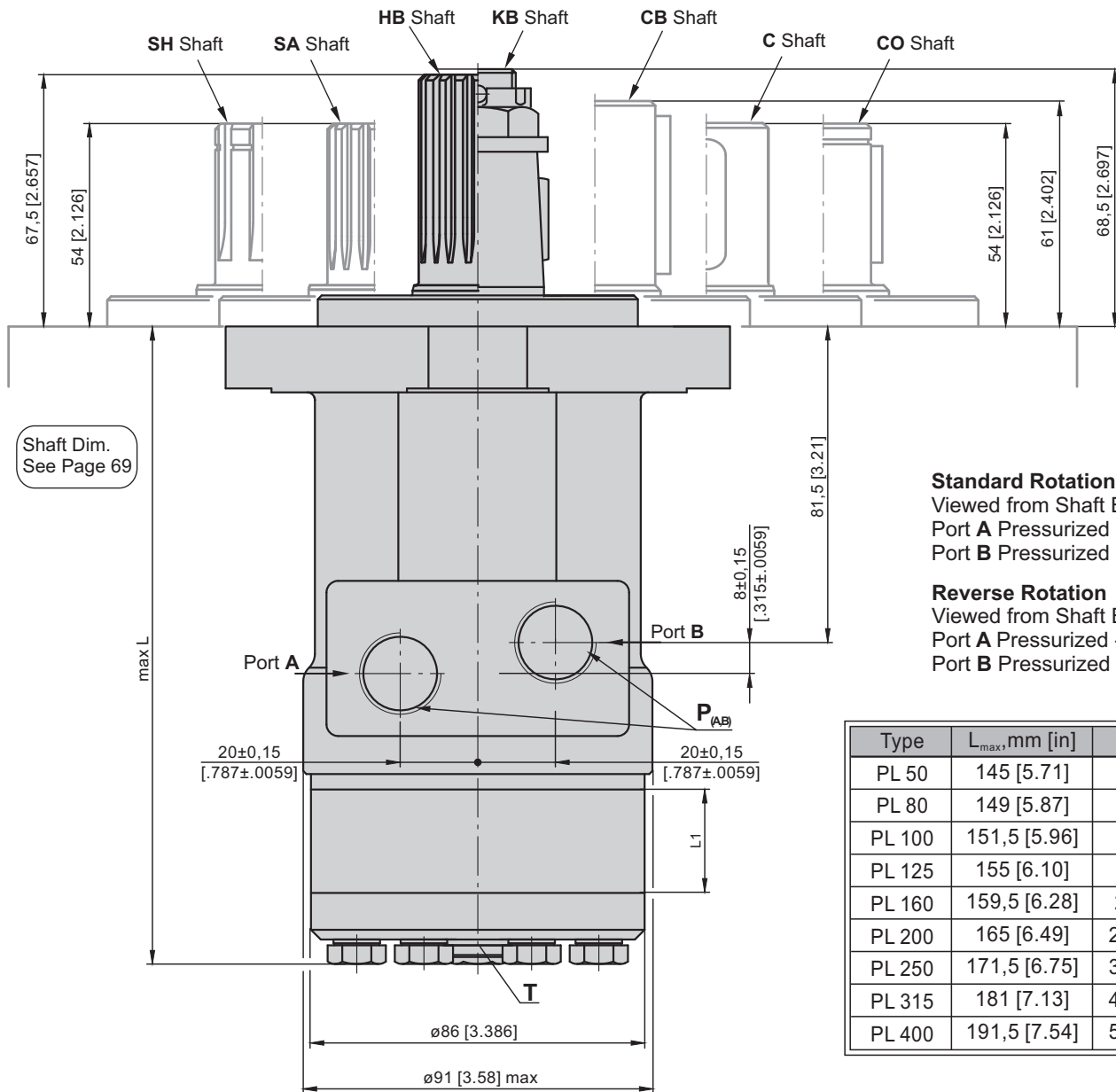

Shaft Dim.
See Page 69

Standard Rotation
Viewed from Shaft End
Port A Pressurized - CW
Port B Pressurized - CCW

Reverse Rotation
Viewed from Shaft End
Port A Pressurized - CCW
Port B Pressurized - CW

Type	L_{max} , mm [in]	L_1 , mm [in]
PL 50	145 [5.71]	6,67 [.26]
PL 80	149 [5.87]	10,67 [.42]
PL 100	151,5 [5.96]	13,33 [.52]
PL 125	155 [6.10]	16,67 [.66]
PL 160	159,5 [6.28]	21,33 [.84]
PL 200	165 [6.49]	26,67 [1.05]
PL 250	171,5 [6.75]	33,33 [1.31]
PL 315	181 [7.13]	42,67 [1.68]
PL 400	191,5 [7.54]	53,33 [2.10]



$P_{(A,B)}$: 2xG1/2 or 2xM22x1,5 - 15 mm [.59 in] depth
 T : G1/4 or M14x1,5 - 12 mm [.47 in] depth

MOUNTING

Square mount (4 Holes)

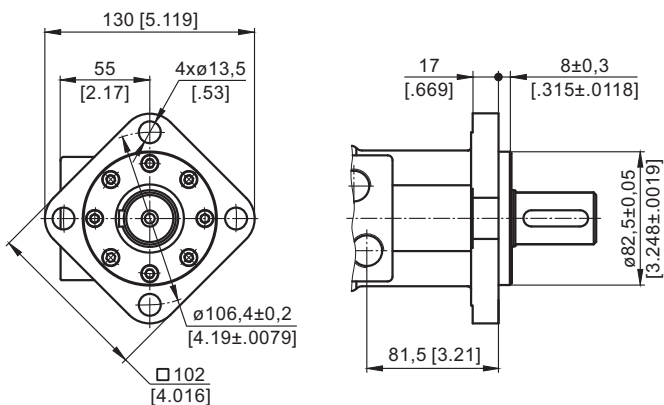

F Oval mount (4 Holes)

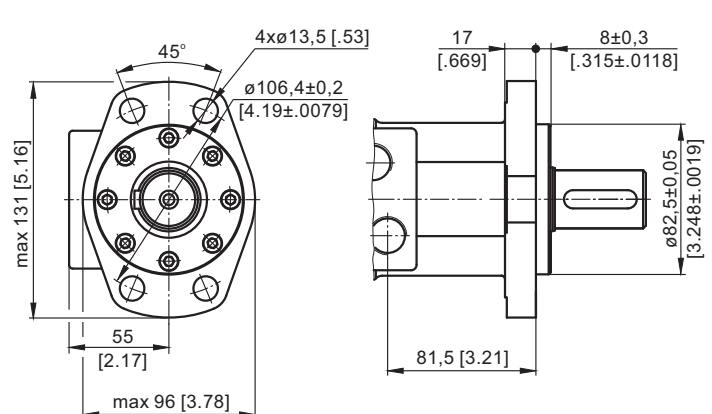

PERMISSIBLE SHAFT LOADS for PL and RL MOTORS

The curves apply to a B10 bearings life of 2000 hrs

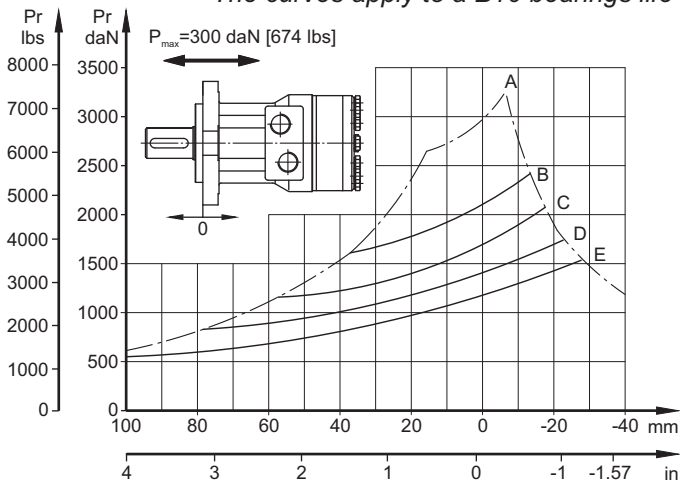

- A - Max. radial shaft load
- B - $n = 50 \text{ min}^{-1}$
- C - $n = 100 \text{ min}^{-1}$
- D - $n = 200 \text{ min}^{-1}$
- E - $n = 400 \text{ min}^{-1}$

MAX. PERMISSIBLE SHAFT SEAL PRESSURE

Max return pressure without drain line or max. pressure in drain line

- - continuous operations
- - - - intermittent operations

- 1: Drawing for Standard Shaft Seal
- 2: Drawing for High Pressure Seal ("U" Seal)

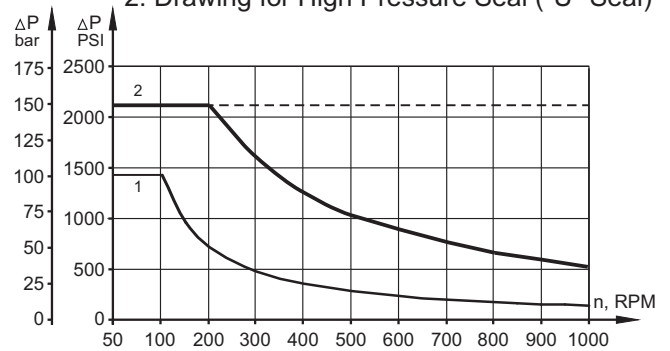

ORDER CODE

	1	2	3	4	5	6	7
PL							

Pos.1 - Mounting Flange

omit - Square mount, four holes

F - Oval mount, four holes

Pos.2 - Displacement code*

50	- 49,5 cm ³ /rev [3.02 in ³ /rev]
80	- 79,2 cm ³ /rev [4.83 in ³ /rev]
100	- 99,0 cm ³ /rev [6.04 in ³ /rev]
125	- 123,8 cm ³ /rev [7.55 in ³ /rev]
160	- 158,4 cm ³ /rev [9.66 in ³ /rev]
200	- 198,0 cm ³ /rev [12.10 in ³ /rev]
250	- 247,5 cm ³ /rev [15.10 in ³ /rev]
315	- 316,8 cm ³ /rev [19.30 in ³ /rev]
400	- 396,0 cm ³ /rev [24.16 in ³ /rev]

Pos.3 - Shaft Extensions**

C	- $\varnothing 25$ straight, Parallel key A8x7x30 DIN6885
CO	- $\varnothing 1$ " straight, Parallel key $1/4$ "x $1/4$ "x $1 1/4$ " BS46
SH	- $\varnothing 25,3$ splined, BS 2059 (SAE 6B)
SA	- $\varnothing 24$ splined, B25x22 DIN 5482
CB	- $\varnothing 32$ straight, Parallel key A10x8x40 DIN6885
HB	- $\varnothing 1 1/4$ " splined 14T ANSI B92.1-1976
KB	- $\varnothing 35$ tapered 1:10, Woodruff key 6x9 DIN6888

Pos.4 - Shaft Seal Version

- omit - Standard shaft seal
- U** - High pressure shaft seal

Pos.5 - Ports

- omit - BSPP (ISO 228)
- M** - Metric (ISO 262)

Pos.6 - Additional Options (see page 125)

Pos.7 - Design Series

- omit - Factory specified

NOTES: * For the Function Diagrams data please look at "M+S Hydraulic" Catalogue for MP motors, pages 19+23.

** The permissible output torque for shafts must not be exceeded.

The hydraulic motors are mangano-phosphatized as standard.

HYDRAULIC MOTORS RL

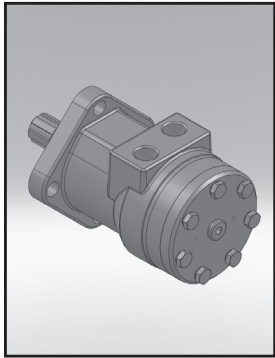

APPLICATION

- » Conveyors
- » Feeding mechanism of robots and manipulators
- » Metal working machines
- » Textile machines
- » Agricultural machines
- » Food industries
- » Mining machinery etc.

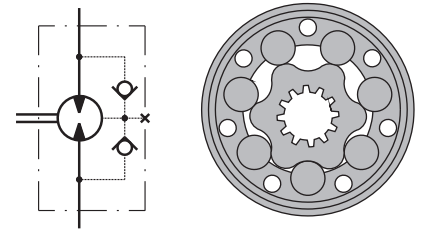

CONTENTS

Specification data	72
Dimensions and mounting	73
Shaft extensions	74
Permissible shaft loads	75
Order code	75

OPTIONS

- » Model - Spool valve, gerotor
- » Antifriction needle bearing
- » Flange mount
- » Shafts - straight, splined and tapered
- » Metric and BSPP ports
- » Other special features

GENERAL

Max. Displacement, cm ³ /rev [in ³ /rev]	397 [24.4]
Max. Speed, [RPM]	970
Max. Torque, daNm [lb-in]	cont.: 61 [5400] int.: 69 [6100]
Max. Output, kW [HP]	16 [21.5]
Max. Pressure Drop, bar [PSI]	cont.: 175 [2540] int.: 200 [2900]
Max. Oil Flow, lpm [GPM]	75 [19.8]
Min. Speed, [RPM]	10
Permissible Shaft Loads, daN [lbs]	P _a =500 [1124]
Pressure fluid	Mineral based- HLP(DIN 51524) or HM(ISO 6743/4)
Temperature range, °C [°F]	-40÷140 [-40÷284]
Optimal Viscosity range, mm ² /s [SUS]	20÷75 [98÷347]
Filtration	ISO code: 18/16/13 According to ISO 4406-1999

Oil flow in drain line

Pressure drop bar [PSI]	Viscosity mm ² /s [SUS]	Oil flow in drain line lpm [GPM]
100 [1450]	20 [98]	2,5 [.660]
	35 [164]	1,8 [.476]
140 [2030]	20 [98]	3,5 [.925]
	35 [164]	2,8 [.740]

Pressure Losses

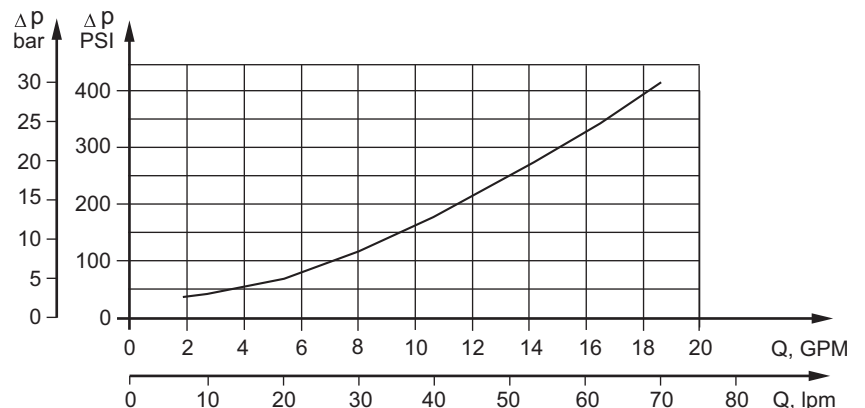

SPECIFICATION DATA

Type	RL 50	RL 80	RL 100	RL 125	RL 160	RL 200	RL 250	RL 315	RL 400	
Displacement, cm³/rev [in³/rev]	51,5 [3.14]	80,3 [4.90]	99,8 [6.09]	125,7 [7.67]	159,6 [9.74]	199,8[12.19]	250,1[15.26]	315,7[19.26]	397 [24.4]	
Max. Speed, [RPM]	Cont.	775	750	600	475	375	300	240	190	
	Int.*	970	940	750	600	470	375	300	240	
Max. Torque, daNm [lb-in]	Cont.	10 [885]	19,5 [1725]	24 [2125]	30 [2655]	38 [3360]	45 [4000]	54 [4780]	55 [4870]	61 [5400]
	Int.*	13 [1150]	22 [1947]	28 [2480]	34 [3010]	43 [3805]	50 [4425]	61 [5400]	69 [6100]	69 [6100]
	Peak**	17 [1505]	27 [2390]	32 [2832]	37 [3275]	46 [4070]	56 [4960]	71 [6280]	84 [77430]	87 [7700]
Max. Output, kW [HP]	Cont.	7 [9.5]	12,5 [17]	13 [17.4]	12,5 [16.8]	12,5 [16.8]	11 [14.8]	10 [13.4]	9 [12]	7,5 [10]
	Int.*	8,5 [11.9]	15 [20.1]	15 [20.1]	14,5 [19]	14 [18.8]	13 [17.4]	12 [16.1]	10 [13.4]	9 [12]
Max. Pressure Drop, bar [PSI]	Cont.	140 [2030]	175 [2540]	175 [2540]	175 [2540]	175 [2540]	175 [2540]	175 [2540]	135 [1960]	110 [1600]
	Int.*	175 [2540]	200 [2900]	200 [2900]	200 [2900]	200 [2900]	200 [2900]	200 [2900]	175 [2540]	140 [2030]
	Peak**	225 [3260]	225 [3260]	225 [3260]	225 [3260]	225 [3260]	225 [3260]	225 [3260]	210 [3045]	175 [2540]
Max. Oil Flow, lpm [GPM]	Cont.	40 [11]	60 [16]	60 [16]	60 [16]	60 [16]	60 [16]	60 [16]	60 [16]	60 [16]
	Int.*	50 [13]	75 [20]	75 [20]	75 [20]	75 [20]	75 [20]	75 [20]	75 [20]	75 [20]
Max. Inlet Pressure, bar [PSI]	Cont.	175 [2540]	175 [2540]	175 [2540]	175 [2540]	175 [2540]	175 [2540]	175 [2540]	175 [2540]	175 [2540]
	Int.*	200 [2900]	200 [2900]	200 [2900]	200 [2900]	200 [2900]	200 [2900]	200 [2900]	200 [2900]	200 [2900]
	Peak**	225 [3260]	225 [3260]	225 [3260]	225 [3260]	225 [3260]	225 [3260]	225 [3260]	225 [3260]	225 [3260]
Max. Return Pressure without Drain Line or Max. Pressure in Drain Line, bar [PSI]	Cont. 0-100 RPM	100 [1450]	100 [1450]	100 [1450]	100 [1450]	100 [1450]	100 [1450]	100 [1450]	100 [1450]	100 [1450]
	Cont. 100-300 RPM	50 [725]	50 [725]	50 [725]	50 [725]	50 [725]	50 [725]	50 [725]	50 [725]	50 [725]
	Cont. 300-600 RPM	25 [365]	25 [365]	25 [365]	25 [365]	25 [365]	25 [365]	25 [365]	25 [365]	25 [365]
	Cont. >600 RPM	15 [220]	15 [220]	15 [220]	15 [220]	15 [220]	15 [220]	15 [220]	15 [220]	15 [220]
	Int.* 0-max RPM	100 [1450]	100 [1450]	100 [1450]	100 [1450]	100 [1450]	100 [1450]	100 [1450]	100 [1450]	100 [1450]
Max. Return Pressure with Drain Line, bar [PSI]	Cont.	140 [2030]	175 [2540]	175 [2540]	175 [2540]	175 [2540]	175 [2540]	175 [2540]	175 [2540]	175 [2540]
	Int.*	175 [2540]	200 [2900]	200 [2900]	200 [2900]	200 [2900]	200 [2900]	200 [2900]	200 [2900]	200 [2900]
	Peak**	225 [3260]	225 [3260]	225 [3260]	225 [3260]	225 [3260]	225 [3260]	225 [3260]	225 [3260]	225 [3260]
Max. Starting Pressure with Unloaded Shaft, bar [PSI]	10 [145]	10 [145]	10 [145]	9 [130]	7 [102]	5 [73]	5 [73]	5 [73]	5 [73]	
Min. Starting Torque, daNm [lb-in]	8 [710]	15 [1330]	20 [1770]	25 [2215]	32 [2835]	37 [3275]	45 [3983]	45 [3983]	49 [4335]	
Min. Speed***, [RPM]	10	10	10	10	10	10	10	10	10	
Weight, kg [lb]	7,7 [17]	7,8 [17.2]	8,1 [17.8]	8,2 [18]	8,4 [18.5]	8,9 [19.6]	9,3 [20.5]	10,0 [22]	10,7 [23.6]	

* Intermittent operation: the permissible values may occur for max. 10% of every minute.

** Peak load: the permissible values may occur for max. 1% of every minute.

*** For speeds lower than given, consult factory or your regional manager.

- Intermittent speed and intermittent pressure must not occur simultaneously.
- Recommended filtration is per ISO cleanliness code 20/16. A nominal filtration of 25 micron or better.
- Recommend using a premium quality, anti-wear type mineral based hydraulic oil HLP(DIN51524) or HM (ISO 6743/4).
If using synthetic fluids consult the factory for alternative seal materials.
- Recommended minimum oil viscosity 13 mm²/s [70 SUS] at 50°C [122°F].
- Recommended maximum system operating temperature is 82°C [180°F].
- To assure optimum motor life fill with fluid prior to loading and run at moderate load and speed for 10-15 minutes.

DIMENSIONS and MOUNTING DATA

Shaft Dim.
See Page 74

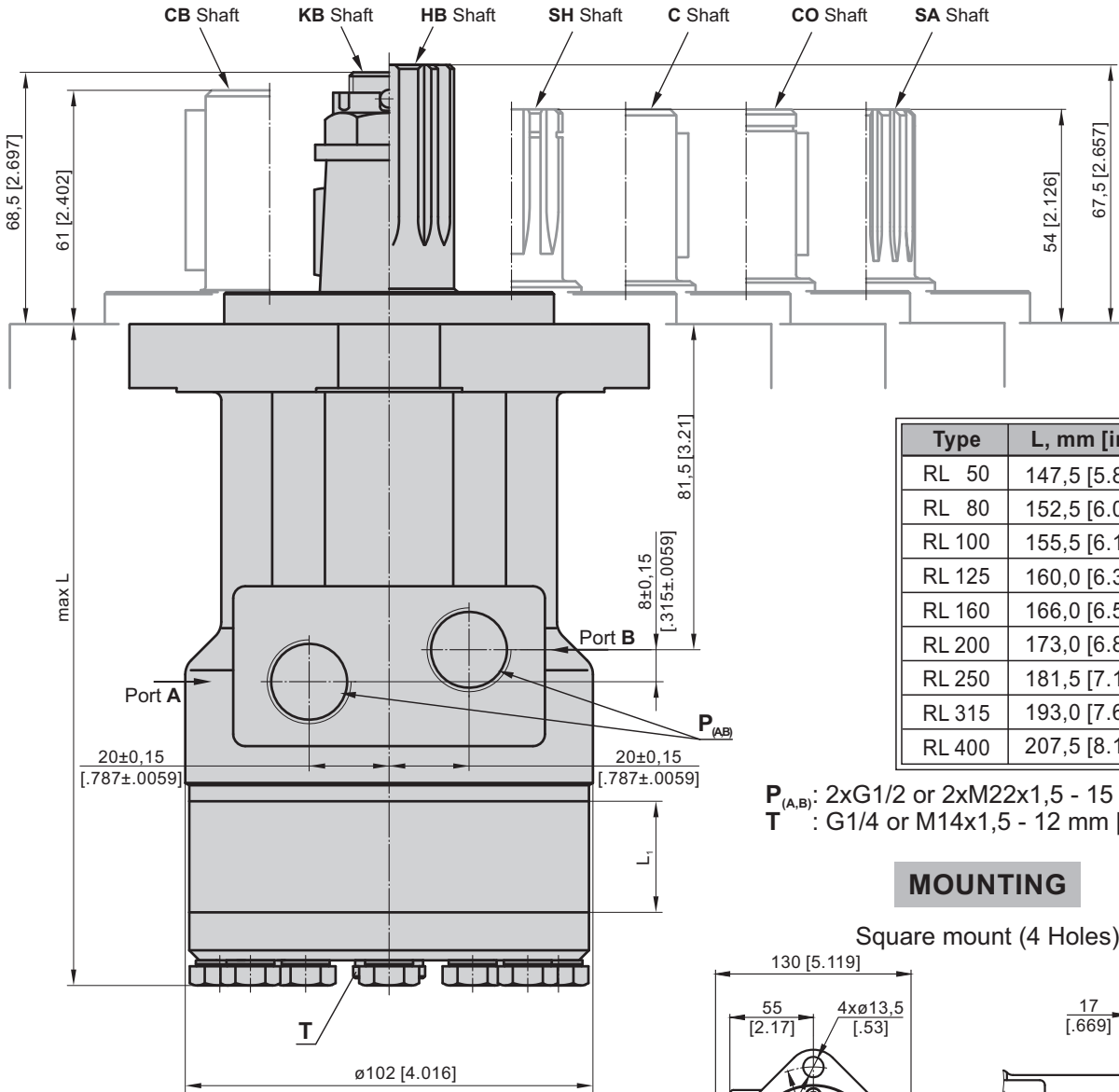

Type	L, mm [in]	L ₁ , mm [in]
RL 50	147,5 [5.80]	9,0 [.35]
RL 80	152,5 [6.00]	14,0 [.55]
RL 100	155,5 [6.12]	17,4 [.69]
RL 125	160,0 [6.30]	21,8 [.86]
RL 160	166,0 [6.54]	27,8 [1.09]
RL 200	173,0 [6.81]	34,8 [1.37]
RL 250	181,5 [7.15]	43,5 [1.71]
RL 315	193,0 [7.60]	54,8 [2.16]
RL 400	207,5 [8.17]	69,4 [2.73]

P_(A,B): 2xG1/2 or 2xM22x1,5 - 15 mm [.59 in] depth
T: G1/4 or M14x1,5 - 12 mm [.47 in] depth

MOUNTING

Square mount (4 Holes)

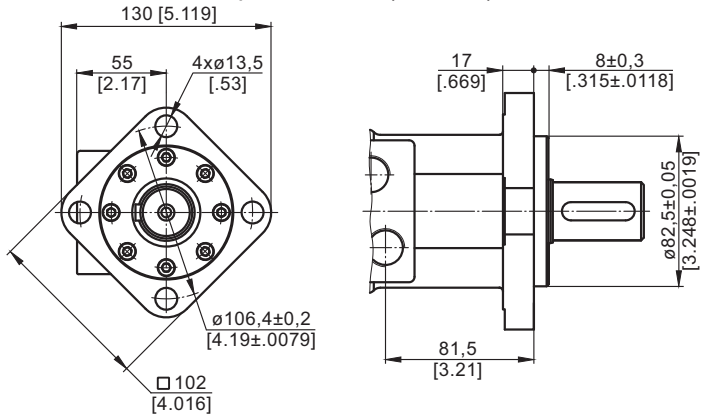

Standard Rotation
Viewed from Shaft End
Port A Pressurized - CW
Port B Pressurized - CCW



Reverse Rotation
Viewed from Shaft End
Port A Pressurized - CCW
Port B Pressurized - CW

F Oval mount (4 Holes)

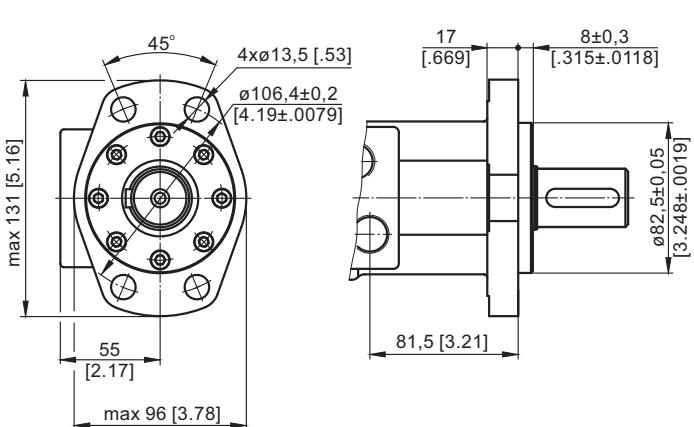

A Oval mount (2 Holes)

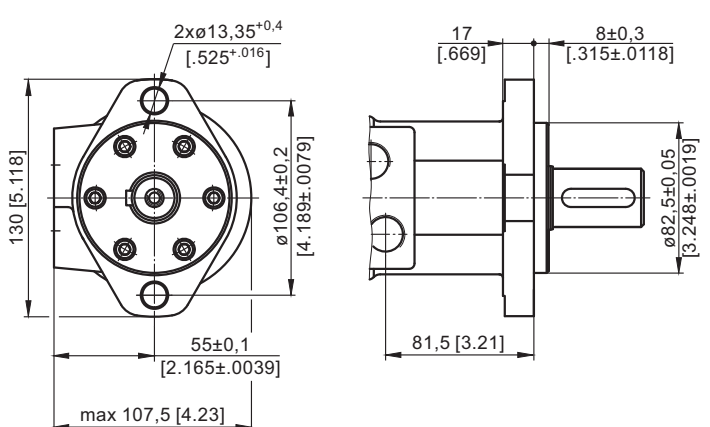

SHAFT EXTENSIONS

C - $\varnothing 25$ straight, Parallel key A8x7x30 DIN 6885
Max. Torque 34 daNm [3010 lb-in]

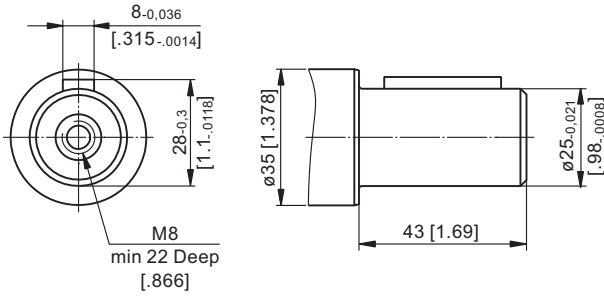

SA - splined B25x22 DIN 5482
Max. Torque 40 daNm [3540 lb-in]

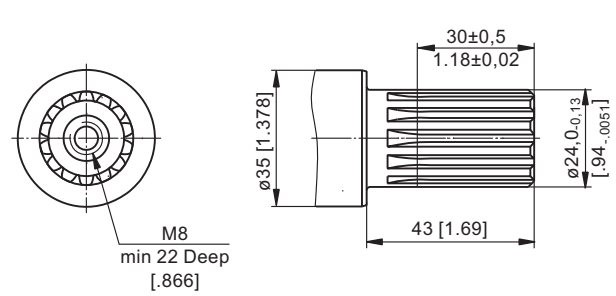

CO - $\varnothing 1$ " straight, Parallel key $\frac{1}{4}$ "x $\frac{1}{4}$ "x $\frac{1}{4}$ " BS46
Max. Torque 34 daNm [3010 lb-in]

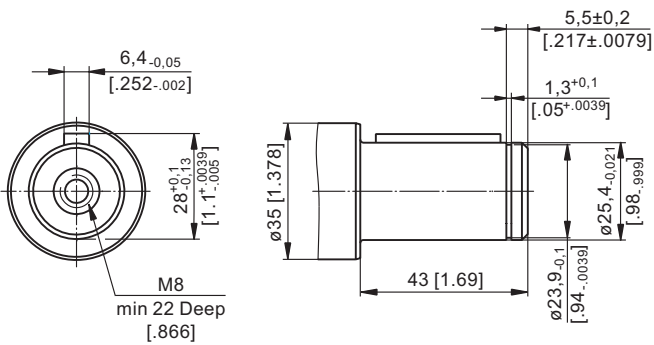

CB - $\varnothing 32$ straight, Parallel key A10x8x40 DIN 6885
Max. Torque 77 daNm [6815 lb-in]

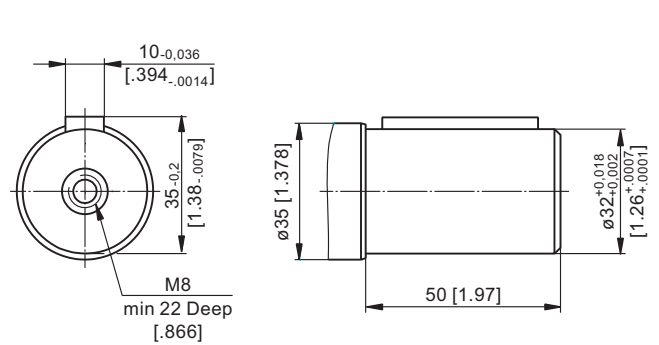

SH - splined, BS 2059 (SAE 6B)
Max. Torque 40 daNm [3540 lb-in]

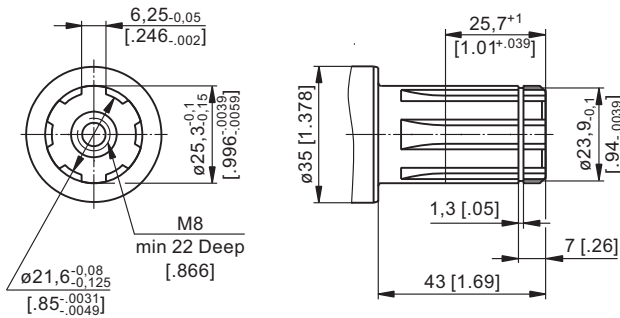

HB - $\varnothing 1\frac{1}{4}$ " splined 14T, DP12/24 ANSI B92.1-1976
Max. Torque 95 daNm [8410 lb-in]

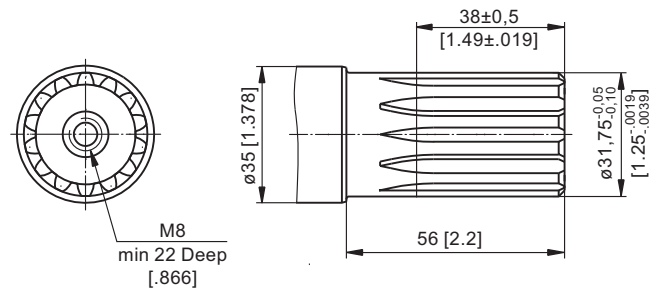

KB - tapered 1:10, Woodruff key 6x9 DIN6888
Max. Torque 95 daNm [8410 lb-in]

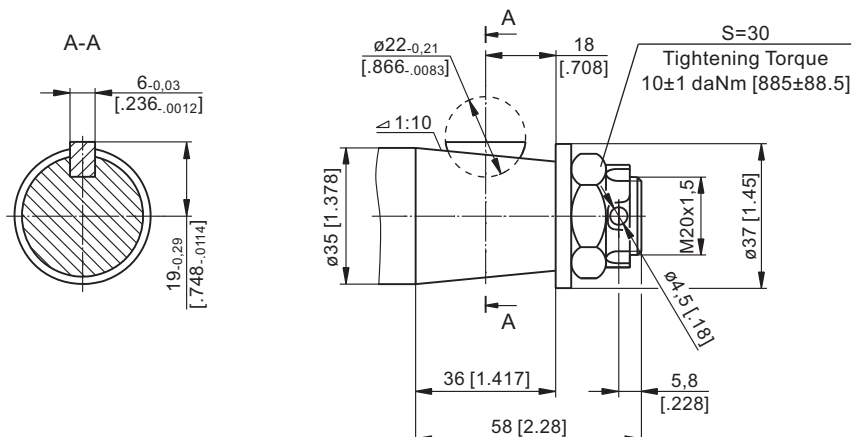

PERMISSIBLE SHAFT LOADS for PL and RL MOTORS

The curves apply to a B10 bearings life of 2000 hrs

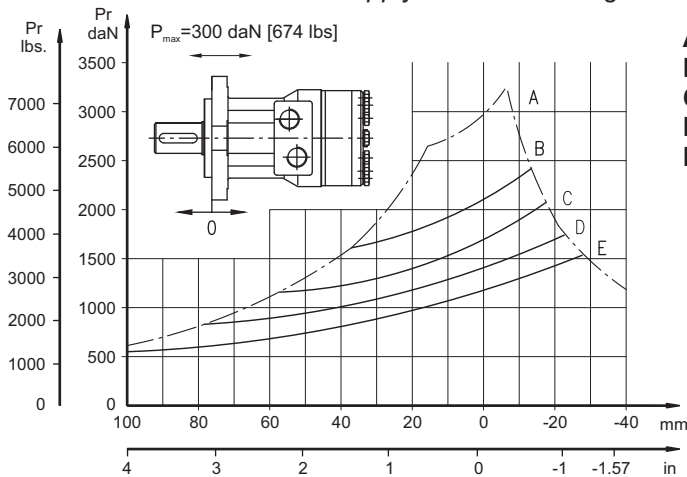

MAX. PERMISSIBLE SHAFT SEAL PRESSURE

Max return pressure without drain line or max. pressure in drain line

— - continuous operations
- - - - intermittent operations

1: Drawing for Standard Shaft Seal
2: Drawing for High Pressure Seal ("U" Seal)

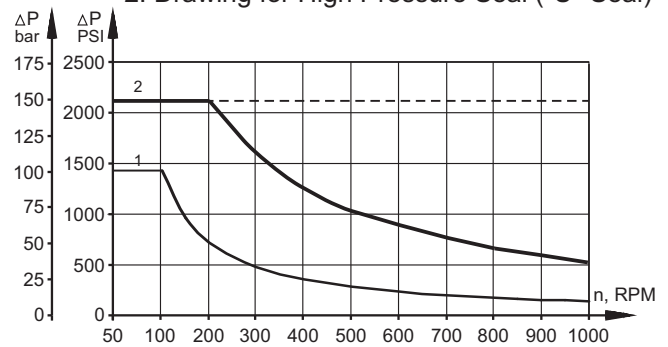

ORDER CODE

1	2	3	4	5	6	7
RL						

Pos.1 - Mounting Flange

- omit - Square mount, four holes
- F** - Oval mount, four holes
- A** - Oval mount, two holes

Pos.2 - Displacement code*

50	- 51,5 cm ³ /rev [3.14 in ³ /rev]
80	- 80,3 cm ³ /rev [4.90 in ³ /rev]
100	- 99,8 cm ³ /rev [6.09 in ³ /rev]
125	- 125,7 cm ³ /rev [7.67 in ³ /rev]
160	- 159,6 cm ³ /rev [9.74 in ³ /rev]
200	- 199,8 cm ³ /rev [12.19 in ³ /rev]
250	- 250,1 cm ³ /rev [15.26 in ³ /rev]
315	- 315,7 cm ³ /rev [19.26 in ³ /rev]
400	- 397,0 cm ³ /rev [24.40 in ³ /rev]

Pos.3 - Shaft Extensions**

- C** - $\varnothing 25$ straight, Parallel key A8x7x30 DIN6885
- CO** - $\varnothing 1$ " straight, Parallel key $1/4$ "x $1/4$ "x $1/4$ " BS46
- SH** - $\varnothing 25,3$ splined, BS 2059 (SAE 6B)
- SA** - $\varnothing 24$ splined, B25x22 DIN 5482
- CB** - $\varnothing 32$ straight, Parallel key A10x8x40 DIN6885
- HB** - $\varnothing 1 1/4$ " splined 14T ANSI B92.1-1976
- KB** - $\varnothing 35$ tapered 1:10, Woodruff key 6x9 DIN6888

Pos.4 - Shaft Seal Version

- omit - Standard shaft seal
- U** - High pressure shaft seal

Pos.5 - Ports

- omit - BSPP (ISO 228)
- M** - Metric (ISO 262)

Pos.6 - Additional Options (see page 125)

Pos.7 - Design Series

- omit - Factory specified

NOTES: * For the Function Diagrams data please look at "M+S Hydraulic" Catalogue for MR motors, pages 35+39.

** The permissible output torque for shafts must not be exceeded.

The hydraulic motors are mangano-phosphatized as standard.

HYDRAULIC MOTORS PK



APPLICATION

- » Conveyors
- » Feeding mechanism of robots and manipulators
- » Metal working machines
- » Textile machines
- » Agricultural machines
- » Food industries
- » Mining machinery etc.

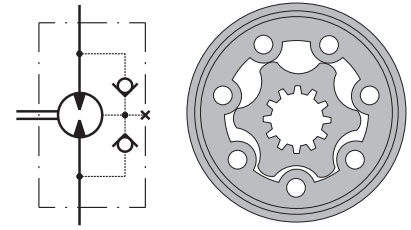

CONTENTS

Specification data 77
 Dimensions and mounting 78
 Shaft extensions 79
 Order code 79

OPTIONS

- » Model - Spool valve, gerotor
- » Flange mount
- » Shafts - straight, splined and tapered
- » Metric and BSPP ports
- » Other special features

GENERAL

Max. Displacement, cm ³ /rev [in ³ /rev]	396 [24.4]
Max. Speed, [RPM]	1010
Max. Torque, daNm [lb-in]	cont.: 40,8 [3611] int.: 55,6 [4921]
Max. Output, kW [HP]	8,6 [11.5]
Max. Pressure Drop, bar [PSI]	cont.: 105 [1520] int.: 140 [2030]
Max. Oil Flow, lpm [GPM]	50 [13.2]
Min. Speed, [RPM]	10
Pressure fluid	Mineral based- HLP(DIN 51524) or HM(ISO 6743/4)
Temperature range, °C [°F]	-40÷140 [-40÷284]
Optimal Viscosity range, mm ² /s [SUS]	20÷75 [98÷347]
Filtration	ISO code: 18/16/13 According to ISO 4406-1999

Oil flow in drain line

Pressure drop bar [PSI]	Viscosity mm ² /s [SUS]	Oil flow in drain line lpm [GPM]
100 [1450]	20 [98]	2,5 [.660]
	35 [164]	1,8 [.476]
140 [2030]	20 [98]	3,5 [.925]
	35 [164]	2,8 [.740]

Pressure Losses

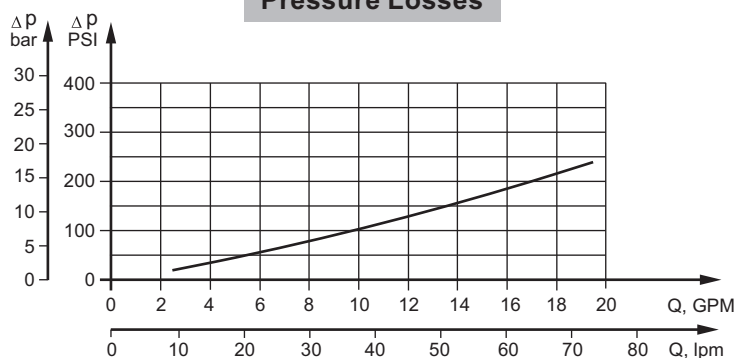

SPECIFICATION DATA

Type	PK 50	PK 80	PK 100	PK 125	PK 160	PK 200	PK 250	PK 315	PK 400	
Displacement, cm³/rev [in³/rev]	49,5[3.02]	79,2 [4.83]	99 [6.04]	123,8 [7.55]	158,4 [966]	198 [12.1]	247,5 [15.1]	316,8 [19.3]	396 [24.16]	
Max. Speed, [RPM]	Cont.	808	505	404	323	252	202	160	126	100
	Int.*	1010	630	505	403	315	252	202	157	126
Max. Torque, daNm [lb-in]	Cont.	7 [619]	10,8 [956]	14,4 [1274]	17 [1504]	22 [1974]	27,5 [2434]	30,1 [2664]	31,7 [2805]	40,8 [3611]
	Int.*	9,2 [814]	14,6 [1292]	18,3 [1619]	22,9 [2026]	29,3 [2593]	36,6 [3239]	37,6 [3328]	44 [3894]	55,6 [4921]
	Peak**	13,6 [1203]	21,4 [1894]	26,1 [2310]	32,6 [2885]	41,8 [3700]	52,2 [4620]	51,5 [4558]	64,3 [5691]	80 [7080]
Max. Output, kW [HP]	Cont.	5,2 [7.0]	5,2 [7.0]	5,2 [7.0]	5,2 [7.0]	5,2 [7.0]	5,2 [7.0]	4,6 [6.2]	3,4 [4.6]	3,4 [4.6]
	Int.*	8,6 [11.5]	8,6 [11.5]	8,6 [11.5]	8,6 [11.5]	8,6 [11.5]	8,6 [11.5]	7 [9.3]	5,8 [7.8]	5,8 [7.8]
Max. Pressure Drop, bar [PSI]	Cont.	105 [1520]	105 [1520]	105 [1520]	105 [1520]	105 [1520]	105 [1520]	90 [1305]	70 [1015]	70 [1015]
	Int.*	140 [2030]	140 [2030]	140 [2030]	140 [2030]	140 [2030]	140 [2030]	115 [1665]	105 [1520]	105 [1520]
	Peak**	215 [3120]	215 [3120]	215 [3120]	215 [3120]	215 [3120]	215 [3120]	170 [2470]	170 [2470]	170 [2470]
Max. Oil Flow, lpm [GPM]	Cont.	40 [10.5]	40 [10.5]	40 [10.5]	40 [10.5]	40 [10.5]	40 [10.5]	40 [10.5]	40 [10.5]	40 [10.5]
	Int.*	50 [13.2]	50 [13.2]	50 [13.2]	50 [13.2]	50 [13.2]	50 [13.2]	50 [13.2]	50 [13.2]	50 [13.2]
Max. Inlet Pressure, bar [PSI]	Cont.	140 [2030]	140 [2030]	140 [2030]	140 [2030]	140 [2030]	140 [2030]	140 [2030]	140 [2030]	140 [2030]
	Int.*	175 [2540]	175 [2540]	175 [2540]	175 [2540]	175 [2540]	175 [2540]	175 [2540]	175 [2540]	175 [2540]
	Peak**	225 [3260]	225 [3260]	225 [3260]	225 [3260]	225 [3260]	225 [3260]	225 [3260]	225 [3260]	225 [3260]
Max. Return Pressure with Drain Line or Max. Pressure in Drain Line, bar [PSI]	Cont. 0-100 RPM	150 [2180]	150 [2180]	150 [2180]	150 [2180]	150 [2180]	150 [2180]	150 [2180]	150 [2180]	150 [2180]
	Cont. 100-300 RPM	75 [1090]	75 [1090]	75 [1090]	75 [1090]	75 [1090]	75 [1090]	75 [1090]	75 [1090]	75 [1090]
	Cont. 300-600 RPM	50 [725]	50 [725]	50 [725]	50 [725]	50 [725]	50 [725]	50 [725]	50 [725]	50 [725]
	Cont. >600 RPM	20 [290]	20 [290]	20 [290]	20 [290]	20 [290]	20 [290]	20 [290]	20 [290]	20 [290]
	Int.* 0-max RPM	15 [220]	15 [220]	15 [220]	15 [220]	15 [220]	15 [220]	15 [220]	15 [220]	15 [220]
Max. Starting Pressure with Unloaded Shaft, bar [PSI]	10 [145]	10 [145]	10 [145]	10 [145]	10 [145]	10 [145]	10 [145]	10 [145]	10 [145]	
Min. Starting Torque, daNm [lb-in]	5,8 [513]	9,1 [805]	12,2 [1079]	14,5 [1283]	19,5 [1725]	24,8 [2195]	27,5 [2433]	29 [2567]	35,9 [3278]	
Min. Speed***, [RPM]	10	10	10	10	10	10	10	10	10	
Weight, kg [lb]	5 [11.1]	5,1 [11.2]	5,3 [11.7]	5,4 [11.9]	5,6 [12.3]	5,8 [12.8]	6 [13.2]	6,3 [13.9]	6,8 [15]	

* Intermittent operation: the permissible values may occur for max. 10% of every minute.

** Peak load: the permissible values may occur for max. 1% of every minute.

*** For speeds lower than given, consult factory or your regional manager.

- Intermittent speed and intermittent pressure must not occur simultaneously.
- Recommended filtration is per ISO cleanliness code 20/16. A nominal filtration of 25 micron or better.
- Recommend using a premium quality, anti-wear type mineral based hydraulic oil HLP(DIN51524) or HM (ISO 6743/4).
If using synthetic fluids consult the factory for alternative seal materials.
- Recommended minimum oil viscosity 13 mm²/s [70 SUS] at 50°C [122°F].
- Recommended maximum system operating temperature is 82°C [180°F].
- To assure optimum motor life fill with fluid prior to loading and run at moderate load and speed for 10-15 minutes.

DIMENSIONS and MOUNTING DATA

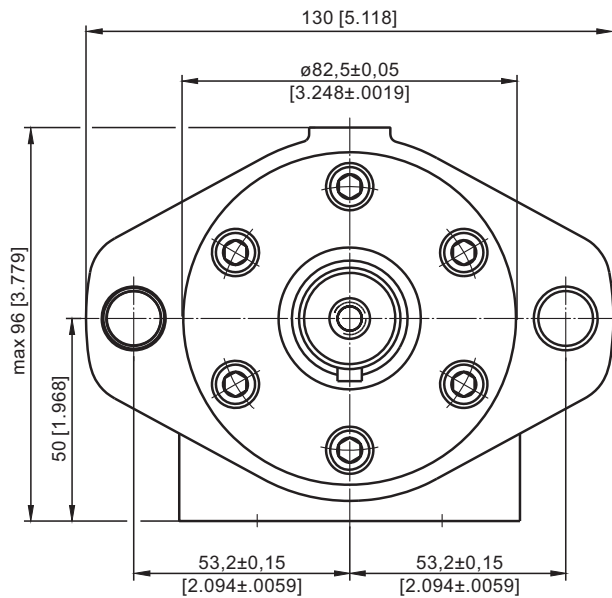
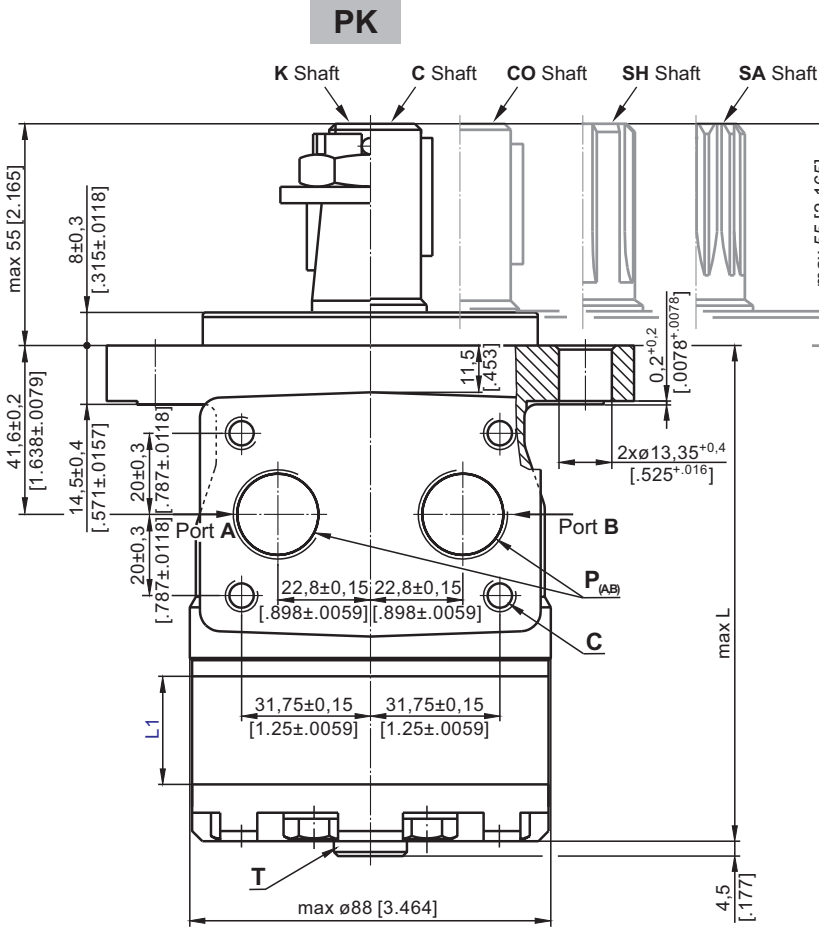

Type	L, mm [in]	Type	L, mm [in]	L ₁ , mm [in]
PK 50	102,5 [4.04]	PKQ 50	113,5 [4.47]	6,67 [.26]
PK 80	106,5 [4.19]	PKQ 80	117,5 [4.63]	10,67 [.42]
PK 100	109,0 [4.29]	PKQ 100	120,0 [4.72]	13,33 [.52]
PK 125	112,5 [4.43]	PKQ 125	123,5 [4.86]	16,67 [.66]
PK 160	117,0 [4.61]	PKQ 160	128,0 [5.04]	21,33 [.84]
PK 200	122,5 [4.82]	PKQ 200	133,5 [5.26]	26,67 [1.05]
PK 250	129,0 [5.08]	PKQ 250	140,0 [5.51]	33,33 [1.31]
PK 315	138,5 [5.45]	PKQ 315	149,5 [5.89]	42,67 [1.68]
PK 400	149,0 [5.87]	PKQ 400	160,0 [6.30]	53,33 [2.10]

PKQ

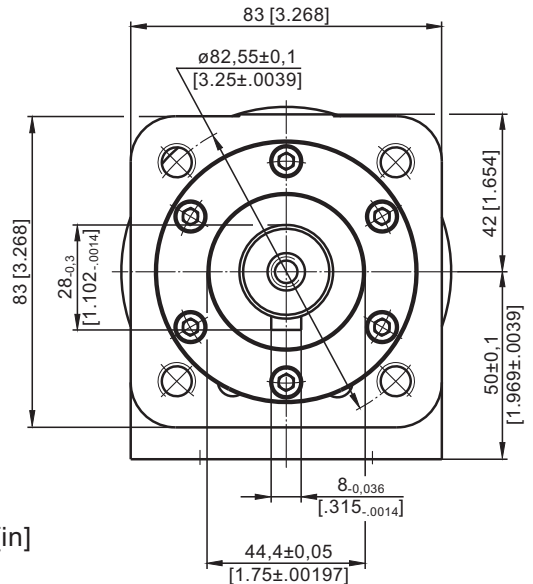
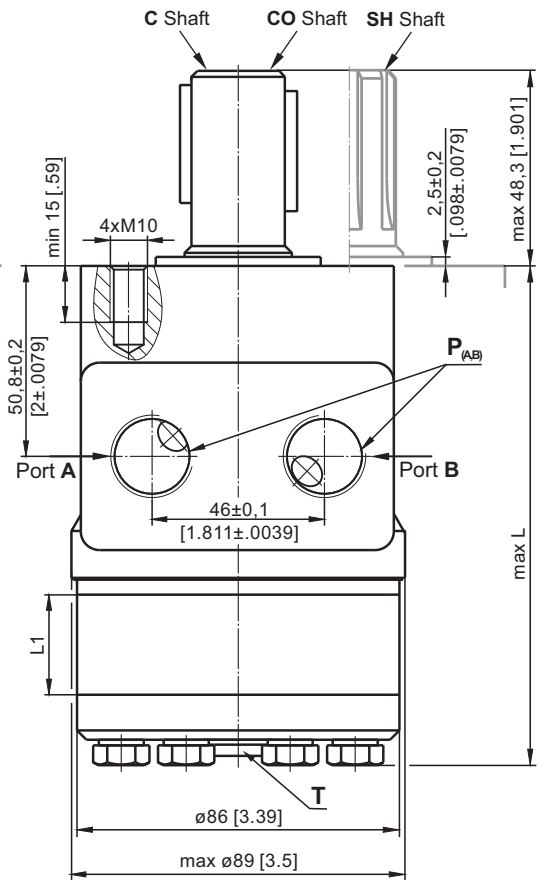

- C** : 4xM8 - 13 mm [.51 in] depth
- P_(A,B)** : 2xG1/2 or 2xM22x1,5 - 15 mm [.59 in] depth
- T** : G1/4 or M14x1,5 - 12 mm [.47 in] depth (plugged)

Standard Rotation

Viewed from Shaft End
Port A Pressurized - CW
Port B Pressurized - CCW

Reverse Rotation

Viewed from Shaft End
Port A Pressurized - CCW
Port B Pressurized - CW

SHAFT EXTENSIONS

C - $\varnothing 25$ straight, Parallel key A8x7x32 DIN 6885
Max. Torque 34 daNm [3010 lb-in]

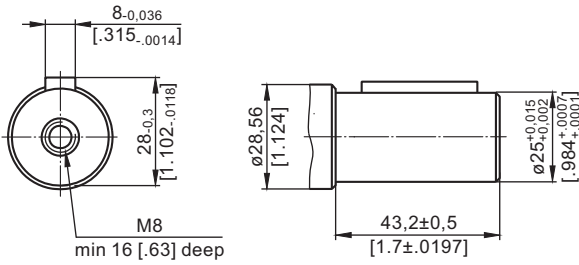

CO - $\varnothing 1$ " straight, Parallel key $\frac{1}{4}$ "x $\frac{1}{4}$ "x $\frac{1}{4}$ " BS46
Max. Torque 34 daNm [3010 lb-in]

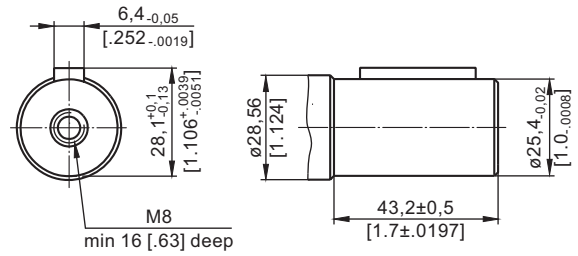

SH - splined, BS 2059 (SAE 6B)
Max. Torque 40 daNm [3540 lb-in]

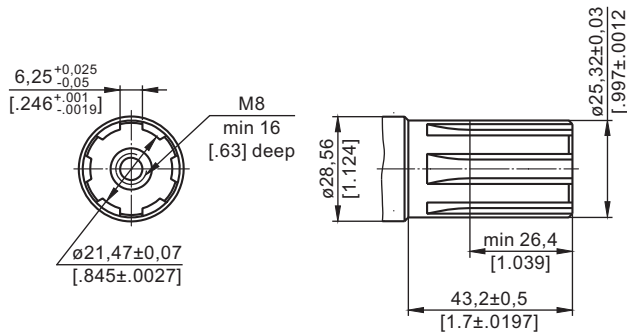

K - tapered 1:10, Parallel key B5x5x14 DIN 6885
Max. Torque 40 daNm [3540 lb-in]

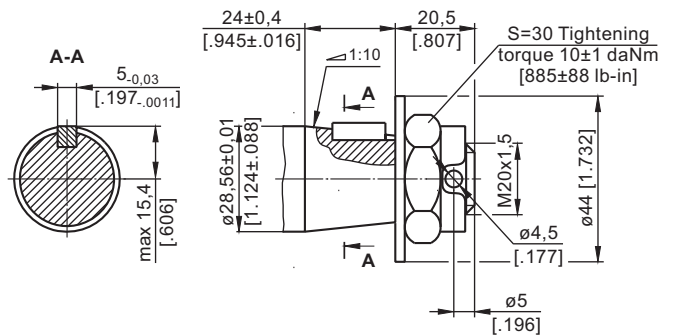

SA - splined, B25x22h9 DIN 5482
Max. Torque 40 daNm [3540 lb-in]

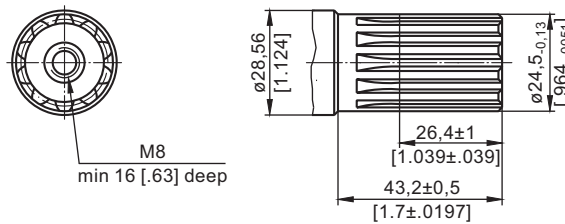

ORDER CODE

	1	2	3	4	5	6
PK						

Pos.1 - Mounting Flange

- omit - Oval mount, two holes
- Q** - Square mount, four holes

Pos.2 - Displacement code

- 50** - 49,5 cm³/rev [3.02 in³/rev]
- 80** - 79,2 cm³/rev [4.83 in³/rev]
- 100** - 99,0 cm³/rev [6.04 in³/rev]
- 125** - 123,8 cm³/rev [7.55 in³/rev]
- 160** - 158,4 cm³/rev [9.66 in³/rev]
- 200** - 198,0 cm³/rev [12.10 in³/rev]
- 250** - 247,5 cm³/rev [15.10 in³/rev]
- 315** - 316,8 cm³/rev [19.30 in³/rev]
- 400** - 396,0 cm³/rev [24.16 in³/rev]

Pos.3 - Shaft Extensions*

- C** - $\varnothing 25$ straight, Parallel key A8x7x32 DIN6885
- CO** - $\varnothing 25,4$ straight, Parallel key $\frac{1}{4}$ "x $\frac{1}{4}$ "x $\frac{1}{4}$ " BS46
- SH** - $\varnothing 25,32$ splined BS 2059 (SAE 6B)
- K** - $\varnothing 28,56$ tapered 1:10, Parallel key, B5x5x14 DIN6885
- SA** - $\varnothing 24,5$ splined B25x22h9 DIN 5482

Pos.4 - Ports

- omit - BSPP (ISO 228)
- M** - Metric (ISO 262)

Pos.5 - Additional Options (see page 125)

Pos.6 - Design Series

- omit - Factory specified

NOTES: * The permissible output torque for shafts must not be exceeded!

The hydraulic motors are manganophosphatized as standard.

HYDRAULIC MOTORS RK

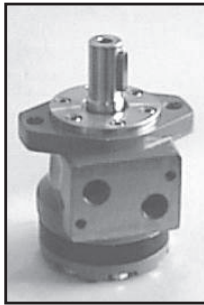

APPLICATION

- » Conveyors
- » Feeding mechanism of robots and manipulators
- » Metal working machines
- » Textile machines
- » Agricultural machines
- » Food industries
- » Mining machinery etc.

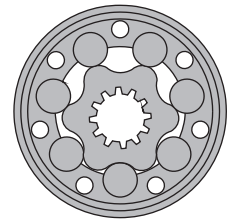
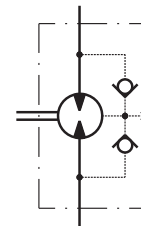

CONTENTS

Specification data 81
 Dimensions and mounting 82
 Shaft extensions 83
 Order code 83

OPTIONS

- » Model - Spool valve, gerotor
- » Flange mount
- » Shafts - straight, splined and tapered
- » Metric and BSPP ports
- » Other special features

GENERAL

Max. Displacement, cm ³ /rev [in ³ /rev]	397 [24.4]
Max. Speed, [RPM]	970
Max. Torque, daNm [lb-in]	cont.: 40 [3540] int.: 50 [4425]
Max. Output, kW [HP]	12,8 [17.2]
Max. Pressure Drop, bar [PSI]	cont.: 140 [2030] int.: 175 [2540]
Max. Oil Flow, lpm [GPM]	75 [19.8]
Min. Speed, [RPM]	10
Pressure fluid	Mineral based- HLP(DIN 51524) or HM(ISO 6743/4)
Temperature range, °C [°F]	-40÷140 [-40÷284]
Optimal Viscosity range, mm ² /s [SUS]	20÷75 [98÷347]
Filtration	ISO code: 18/16/13 According to ISO 4406-1999

Oil flow in drain line

Pressure drop bar [PSI]	Viscosity mm ² /s [SUS]	Oil flow in drain line lpm [GPM]
100 [1450]	20 [98]	2,5 [.660]
	35 [164]	1,8 [.476]
140 [2030]	20 [98]	3,5 [.925]
	35 [164]	2,8 [.740]

Pressure Losses

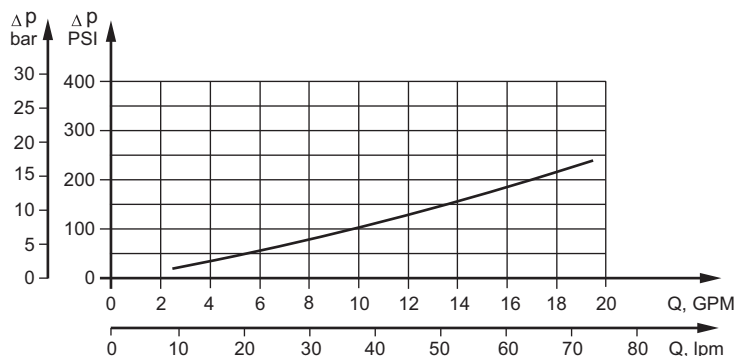

SPECIFICATION DATA

Type	RK 50	RK 80	RK 100	RK 125	RK 160	RK 200	RK 250	RK 315	RK 400	
Displacement, cm³/rev [in³/rev]	51,5 [3.14]	80,3 [4.9]	99,8 [6.09]	125,5 [7.67]	159,6 [9.74]	199,8 [12.19]	250,1 [15.26]	315,7 [19.26]	397 [24.4]	
Max. Speed, [RPM]	Cont.	775	750	600	475	375	300	240	190	150
	Int.*	970	940	750	600	470	375	300	240	185
Max. Torque, daNm [lb-in]	Cont.	10 [850]	15,7 [1390]	19,8 [1750]	25 [2210]	32 [2830]	34 [3010]	40 [3540]	40 [3540]	40 [3540]
	Int.*	13 [1150]	19,5 [1725]	24 [2125]	30 [2655]	39 [3450]	42 [3717]	47 [4160]	50 [4425]	50 [4425]
	Peak**	17 [1505]	27 [2390]	32 [2830]	37 [3275]	46 [4070]	56 [4960]	64 [5665]	65 [5755]	65 [5755]
Max. Output, kW [HP]	Cont.	9 [12.1]	10,4 [13.9]	10,8 [14.4]	10,8 [14.4]	10,4 [13.9]	8,8 [11.8]	8,1 [10.9]	7,4 [9.9]	6,2 [8.3]
	Int.*	10,4 [13.9]	12,6 [16.9]	12,8 [17.2]	12,5 [16.8]	11,5 [15.4]	10,2 [13.7]	9,4 [12.6]	7,8 [10.5]	7,1 [9.5]
Max. Pressure Drop, bar [PSI]	Cont.	140 [2030]	140 [2030]	140 [2030]	140 [2030]	140 [2030]	125 [1810]	110 [1600]	90 [1300]	75 [1090]
	Int.*	175 [2540]	175 [2540]	175 [2540]	175 [2540]	175 [2540]	155 [2250]	140 [2030]	125 [1810]	90 [1305]
	Peak**	225 [3260]	225 [3260]	225 [3260]	225 [3260]	225 [3260]	225 [3260]	200 [2900]	150 [2175]	120 [1740]
Max. Oil Flow, lpm [GPM]	Cont.	40 [10.5]	60 [15.9]	60 [15.9]	60 [15.9]	60 [15.9]	60 [15.9]	60 [15.9]	60 [15.9]	60 [15.9]
	Int.*	50 [13.2]	75 [18.5]	75 [18.5]	75 [18.5]	75 [18.5]	75 [18.5]	75 [18.5]	75 [18.5]	75 [18.5]
Max. Inlet Pressure, bar [PSI]	Cont.	175 [2540]								
	Int.*	200 [2900]								
	Peak**	225 [3260]								
Max. Return Pressure with Drain Line or Max. Pressure in Drain Line, bar [PSI]	Cont. 0-100 RPM	150 [2180]								
	Cont. 100-300 RPM	75 [1090]								
	Cont. 300-600 RPM	50 [725]								
	Cont. >600 RPM	20 [290]								
Int.* 0-max RPM	15 [220]									
Max. Starting Pressure with Unloaded Shaft, bar [PSI]	10 [145]									
Min. Starting Torque, daNm [lb-in]	8 [710]	12 [1060]	16 [1420]	20 [1770]	25 [2215]	29 [2570]	28 [2480]	32 [2832]	35 [3100]	
Min. Speed***, [RPM]	10									
Weight, kg [lb]	6,2 [13.7]	6,3 [13.9]	6,6 [14.6]	6,7 [14.8]	6,9 [15.2]	7,4 [16.3]	7,8 [17.2]	8,5 [18.7]	9,3 [20.5]	

* Intermittent operation: the permissible values may occur for max. 10% of every minute.

** Peak load: the permissible values may occur for max. 1% of every minute.

*** For speeds lower than given, consult factory or your regional manager.

1. Intermittent speed and intermittent pressure must not occur simultaneously.
2. Recommended filtration is per ISO cleanliness code 20/16. A nominal filtration of 25 micron or better.
3. Recommend using a premium quality, anti-wear type mineral based hydraulic oil HLP(DIN51524) or HM (ISO 6743/4).
If using synthetic fluids consult the factory for alternative seal materials.
4. Recommended minimum oil viscosity 13 mm²/s [70 SUS] at 50°C [122°F].
5. Recommended maximum system operating temperature is 82°C [180°F].
6. To assure optimum motor life fill with fluid prior to loading and run at moderate load and speed for 10-15 minutes.

DIMENSIONS and MOUNTING DATA

Oval Mount (2 Holes)

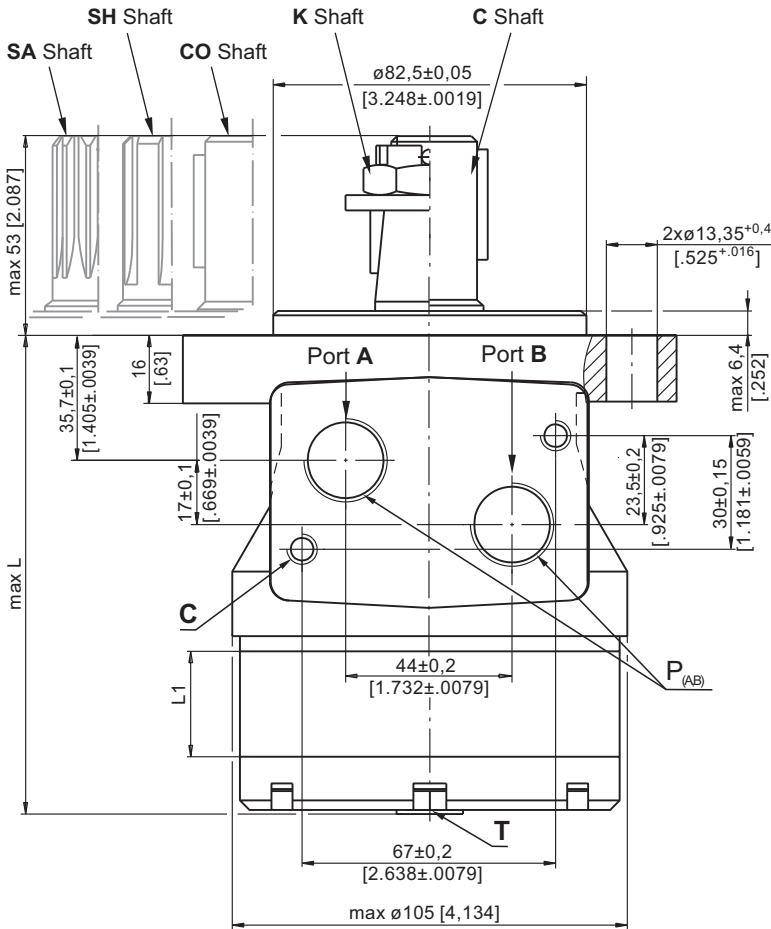

Q - Square Mount (4 Bolts)

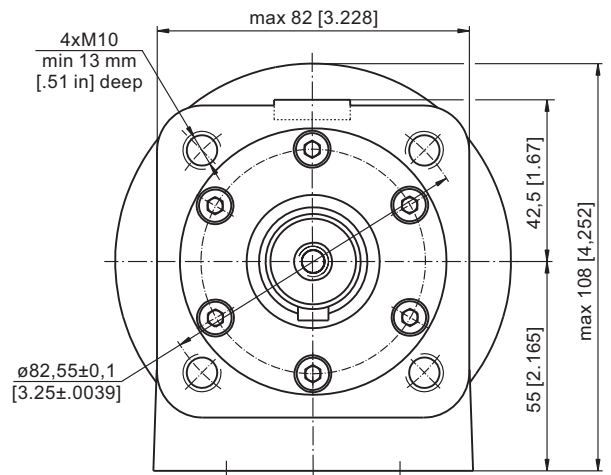
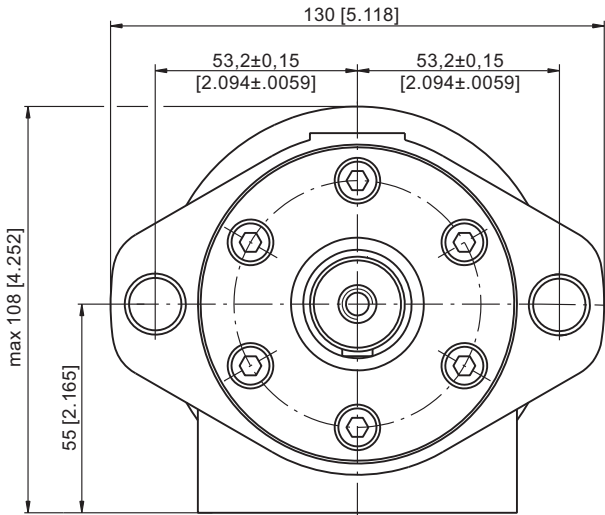
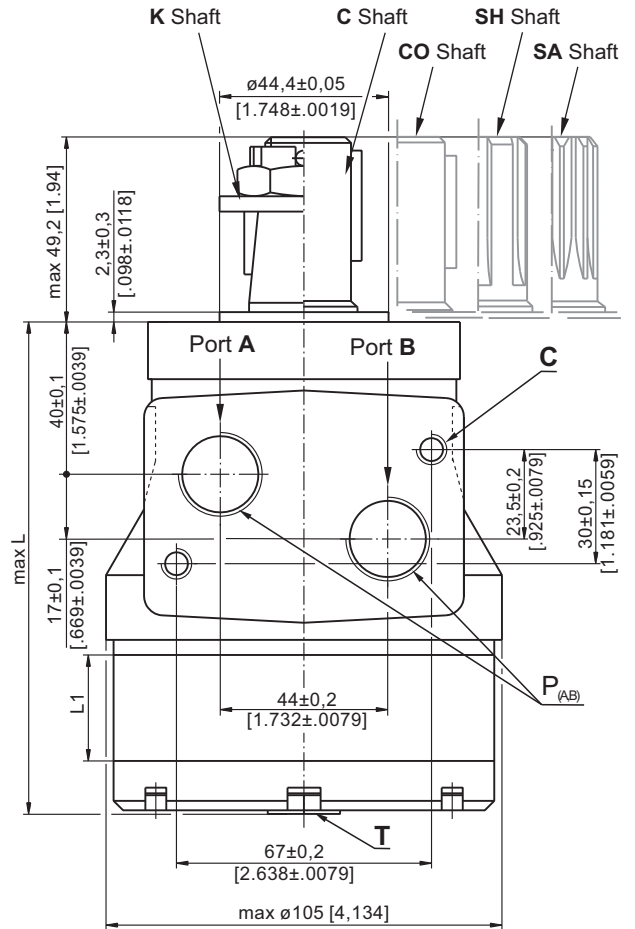

- C** : 2xM8 - 13 mm [.51 in] depth
- P_(A,B)** : 2xG1/2 or 2xM22x1,5 - 15 mm [.59 in] depth
- T** : G1/4 or M14x1,5 - 8,5 mm [.33 in] depth (plugged)

Standard Rotation
Viewed from Shaft End
Port **A** Pressurized - **CW**
Port **B** Pressurized - **CCW**

Reverse Rotation
Viewed from Shaft End
Port **A** Pressurized - **CCW**
Port **B** Pressurized - **CW**



Type	L, mm [in]	Type	L, mm [in]	L, mm [in]
RK 50	109,5 [4.31]	RKQ 50	113,8 [4.48]	9,0 [.35]
RK 80	114,5 [4.51]	RKQ 80	118,8 [4.68]	14,0 [.55]
RK 100	118,0 [4.65]	RKQ 100	122,3 [4.82]	17,4 [.69]
RK 125	122,5 [4.82]	RKQ 125	126,8 [4.99]	21,8 [.86]
RK 160	128,5 [5.06]	RKQ 160	132,8 [5.23]	27,8 [1.09]
RK 200	135,5 [5.33]	RKQ 200	139,8 [5.50]	34,8 [1.37]
RK 250	144,0 [5.67]	RKQ 250	148,3 [5.84]	43,5 [1.71]
RK 315	155,5 [6.12]	RKQ 315	159,8 [6.29]	54,8 [2.16]
RK 400	170,0 [6.69]	RKQ 400	174,3 [6.86]	69,4 [2.73]

SHAFT EXTENSIONS

C - $\varnothing 25$ straight, Parallel key A8x7x32 DIN 6885
Max. Torque 34 daNm [3010 lb-in]

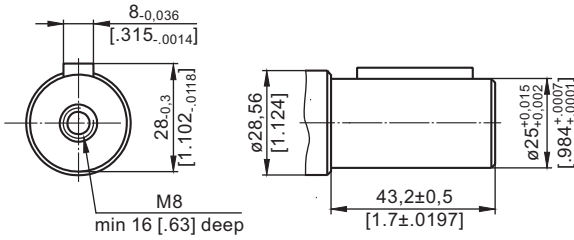

CO - $\varnothing 1"$ straight, Parallel key $\frac{1}{4} \times \frac{1}{4} \times 1\frac{1}{4}$ " BS46
Max. Torque 34 daNm [3010 lb-in]

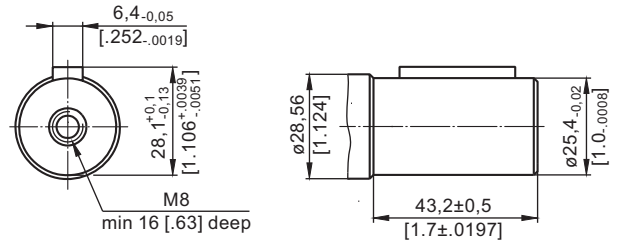

SH - splined, BS 2059 (SAE 6B)
Max. Torque 40 daNm [3540 lb-in]

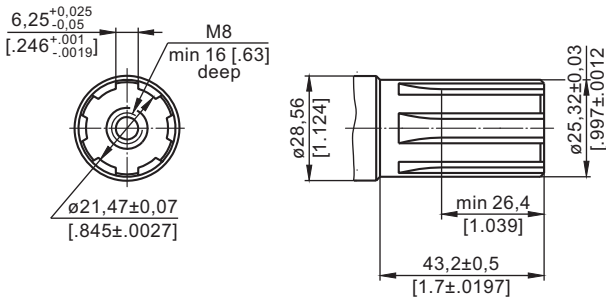

K - tapered, Parallel key B5x5x14 DIN 6885
Max. Torque 40 daNm [3540 lb-in]

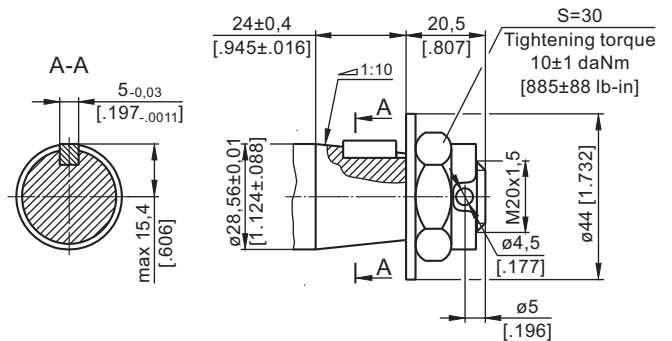

SA - splined, B25x22h9 DIN 5482
Max. Torque 40 daNm [3540 lb-in]

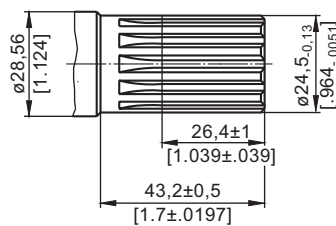
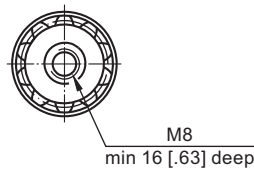

ORDER CODE

1	2	3	4	5	6
RK					

Pos.1 - Mounting Flange

- omit - Oval mount, two holes
- Q** - Square mount, four holes

Pos.2 - Displacement code*

50	- 51,5 cm ³ /rev [3.14 in ³ /rev]
80	- 80,3 cm ³ /rev [4.90 in ³ /rev]
100	- 99,8 cm ³ /rev [6.09 in ³ /rev]
125	- 125,7 cm ³ /rev [7.67 in ³ /rev]
160	- 159,6 cm ³ /rev [9.74 in ³ /rev]
200	- 199,8 cm ³ /rev [12.19 in ³ /rev]
250	- 250,1 cm ³ /rev [15.26 in ³ /rev]
315	- 315,7 cm ³ /rev [19.26 in ³ /rev]
400	- 397,0 cm ³ /rev [24.40 in ³ /rev]

Pos.3 - Shaft Extensions**

- C** - $\varnothing 25$ straight, Parallel key A8x7x32 DIN6885
- CO** - $\varnothing 25,4$ straight, Parallel key $\frac{1}{4} \times \frac{1}{4} \times 1\frac{1}{4}$ " Bs46
- SH** - $\varnothing 25,32$ splined, BS 2059 (SAE 6B)
- K** - $\varnothing 28,56$ tapered 1:10, Parallel key, B5x5x14 DIN 6885
- SA** - $\varnothing 24,5$ splined B25x22h9 DIN 5482

Pos.4 - Ports

- omit - BSPP (ISO 228)
- M** - Metric (ISO 262)

Pos.5 - Additional Options (see page 125)

Pos.6 - Design Series

- omit - Factory specified

NOTES: * The permissible output torque for shafts must not be exceeded!

The hydraulic motors are manganophosphatized as standard.

HYDRAULIC MOTORS RW



APPLICATION

- » Conveyors
- » Feeding mechanism of robots and manipulators
- » Metal working machines
- » Textile machines
- » Agricultural machines
- » Food industries
- » Grass cutting machinery etc.

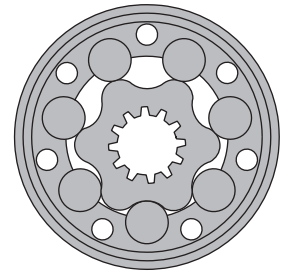

CONTENTS

Specification data	85
Function diagrams	86÷90
Permissible shaft seal pressure	90
Dimensions and mounting	91
Permissible shaft loads	92
Shaft extensions	92
Order code	92

OPTIONS

- » Model - Spool valve, roll-gerotor
- » Flange mount
- » Shafts - straight, splined and tapered
- » Metric and BSPP ports
- » Other special features

GENERAL

Max. Displacement, cm ³ /rev [in ³ /rev]	397 [24.4]
Max. Speed, [RPM]	1029
Max. Torque, daNm [lb-in]	cont.: 61 [5400] int.: 69 [6100]
Max. Output, kW [HP]	15 [20.1]
Max. Pressure Drop, bar [PSI]	cont.: 175 [2540] int.: 200 [2900]
Max. Oil Flow, lpm [GPM]	90 [19.8]
Min. Speed, [RPM]	10
Pressure fluid	Mineral based- HLP(DIN 51524) or HM(ISO 6743/4)
Temperature range, °C [°F]	-40÷140 [-40÷284]
Optimal Viscosity range, mm ² /s [SUS]	20÷75 [98÷347]
Filtration	ISO code: 18/16/13 According to ISO 4406-1999

Oil flow in drain line

Pressure drop bar [PSI]	Viscosity mm ² /s [SUS]	Oil flow in drain line lpm [GPM]
100 [1450]	20 [98]	2,5 [.660]
	35 [164]	1,8 [.476]
140 [2030]	20 [98]	3,5 [.925]
	35 [164]	2,8 [.740]

Pressure Losses

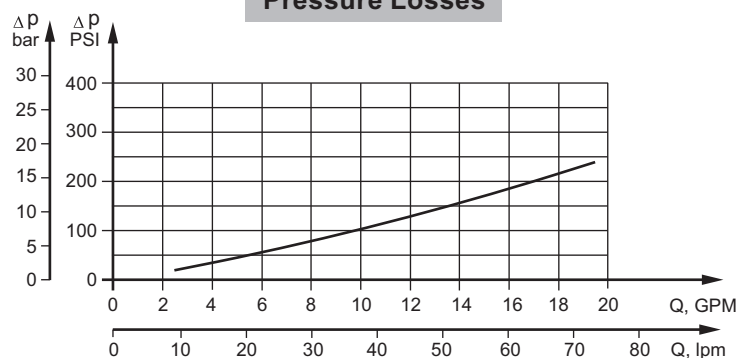

SPECIFICATION DATA

Type		RW 50	RW 80	RW 100	RW 125	RW 160	RW 200	RW 250	RW 315	RW 400
Displacement, cm³/rev		51,5	80,3	99,8	125,7	159,6	199,8	250,1	315,7	397
	[in³/rev]	[3.14]	[4.90]	[6.09]	[7.67]	[9.74]	[12.19]	[15.26]	[19.26]	[24.4]
Max. Speed, [RPM]	Cont.	775	750	600	475	375	300	300	240	190
	Int.*	1029	940	750	600	470	375	360	285	226
Max. Torque, daNm [lb-in]	Cont.	10 [900]	20 [1770]	24 [2125]	30 [2655]	39 [3450]	45 [4000]	54 [4780]	55 [4870]	61 [5400]
	Int.*	13 [1150]	22 [1947]	28 [2480]	34 [3010]	43 [3805]	50 [4425]	61 [5400]	69 [6100]	69 [6100]
	Peak**	17 [1505]	27 [2390]	32 [2832]	37 [3275]	46 [4070]	56 [4960]	71 [6280]	84 [7430]	87 [7700]
Max. Output, kW [HP]	Cont.	7 [9.5]	12,5 [17]	13 [17.4]	12,5 [16.8]	11,5 [15.4]	11 [14.8]	10 [13.4]	9 [12]	7,8 [10.5]
	Int.*	8,5 [11.9]	15 [20.1]	15 [20.1]	14,5 [19.5]	14 [18.8]	13 [17.4]	12 [16.1]	10 [13.4]	10,6 [14.2]
Max. Pressure Drop, bar [PSI]	Cont.	140 [2030]	175 [2540]	175 [2540]	175 [2540]	175 [2540]	175 [2540]	175 [2540]	135 [1960]	110 [1600]
	Int.*	175 [2540]	200 [2900]	200 [2900]	200 [2900]	200 [2900]	200 [2900]	200 [2900]	175 [2540]	140 [2030]
	Peak**	225 [3260]	225 [3260]	225 [3260]	225 [3260]	225 [3260]	225 [3260]	225 [3260]	210 [3045]	175 [2540]
Max. Oil Flow, lpm [GPM]	Cont.	40 [10,6]	60 [15,9]	60 [15,9]	60 [15,9]	60 [15,9]	60 [15,9]	75 [19,8]	75 [19,8]	75 [19,8]
	Int.*	50 [13,2]	75 [19,8]	75 [19,8]	75 [19,8]	75 [19,8]	75 [19,8]	90 [23,8]	90 [23,8]	90 [23,8]
Max. Inlet Pressure, bar [PSI]	Cont.	175 [2540]	175 [2540]	175 [2540]	175 [2540]	175 [2540]	175 [2540]	175 [2540]	175 [2540]	175 [2540]
	Int.*	200 [2900]	200 [2900]	200 [2900]	200 [2900]	200 [2900]	200 [2900]	200 [2900]	200 [2900]	200 [2900]
	Peak**	225 [3260]	225 [3260]	225 [3260]	225 [3260]	225 [3260]	225 [3260]	225 [3260]	225 [3260]	225 [3260]
Max. Return Pressure with Drain Line, bar [PSI]	Cont.	175 [2540]	175 [2540]	175 [2540]	175 [2540]	175 [2540]	175 [2540]	175 [2540]	175 [2540]	175 [2540]
	Int.*	200 [2900]	200 [2900]	200 [2900]	200 [2900]	200 [2900]	200 [2900]	200 [2900]	200 [2900]	200 [2900]
	Peak**	225 [3260]	225 [3260]	225 [3260]	225 [3260]	225 [3260]	225 [3260]	225 [3260]	225 [3260]	225 [3260]
Max. Starting Pressure with Unloaded Shaft, bar [PSI]		10 [145]	10 [145]	10 [145]	9 [130]	7 [102]	5 [73]	5 [73]	5 [73]	5 [73]
Min. Starting Torque, daNm [lb-in]	At max.press. drop Cont.	8 [710]	15 [1330]	20 [1770]	25 [2215]	32 [2832]	41 [3630]	50 [4425]	50 [4425]	50 [4425]
	At max.press. drop Int.*	10 [885]	17 [1505]	23 [2035]	28 [2480]	37 [3275]	46 [4070]	55 [4870]	66 [5840]	61 [5400]
Min. Speed***, [RPM]		10	10	10	10	10	10	10	10	10
Weight, kg [lb]		9,6	9,7	9,8	10,0	10,3	10,8	11,3	11,8	12,5
		[21.2]	[21.4]	[21.7]	[22.1]	[22.7]	[23.8]	[24.9]	[26]	[27.63]

* Intermittent operation: the permissible values may occur for max. 10% of every minute.

** Peak load: the permissible values may occur for max. 1% of every minute.

*** For speeds lower than given, consult factory or your regional manager.

- Intermittent speed and intermittent pressure must not occur simultaneously.
- Recommended filtration is per ISO cleanliness code 20/16. A nominal filtration of 25 micron or better.
- Recommend using a premium quality, anti-wear type mineral based hydraulic oil HLP(DIN51524) or HM (ISO 6743/4).
If using synthetic fluids consult the factory for alternative seal materials.
- Recommended minimum oil viscosity 13 mm²/s [70 SUS] at 50°C [122°F].
- Recommended maximum system operating temperature is 82°C [180°F].
- To assure optimum motor life fill with fluid prior to loading and run at moderate load and speed for 10-15 minutes.

FUNCTION DIAGRAMS

RW 50

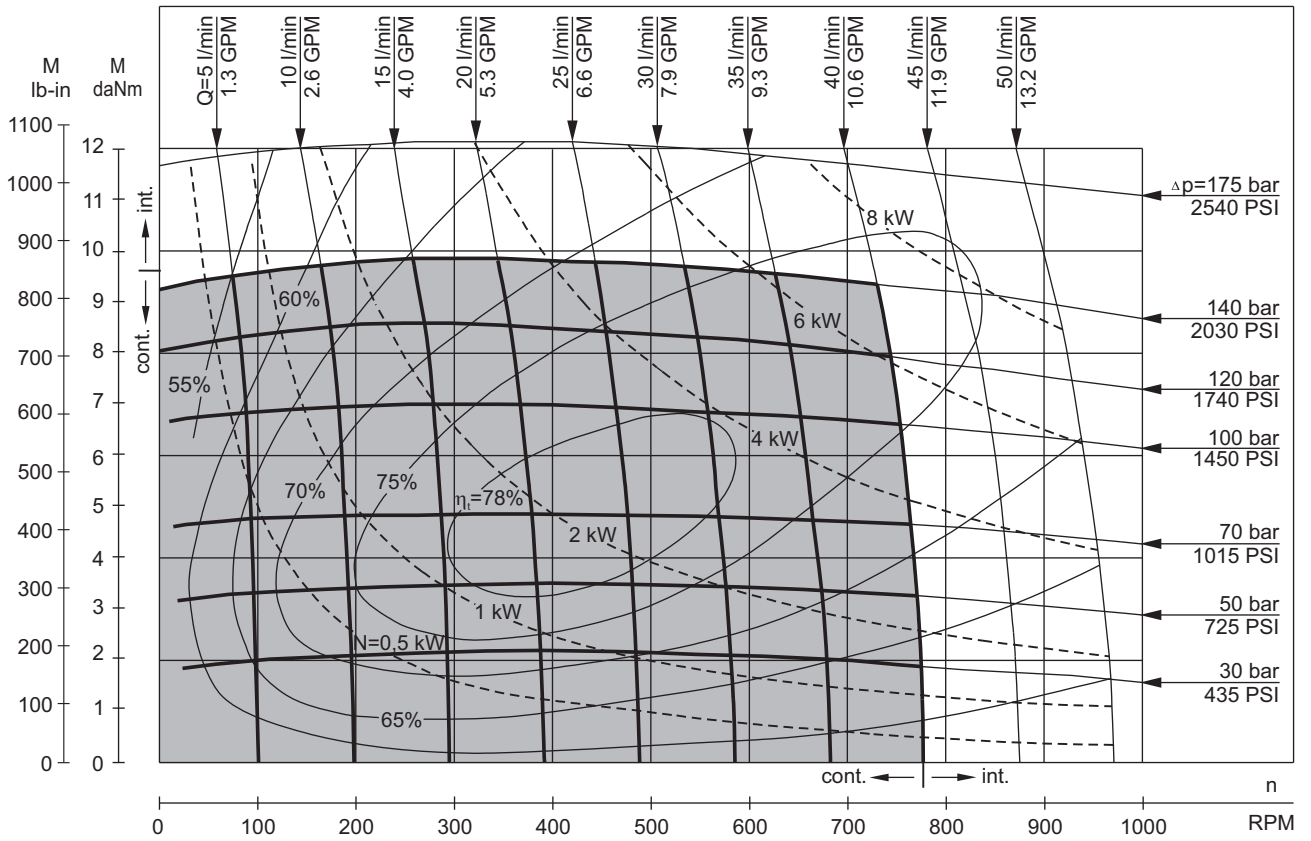

RW 80

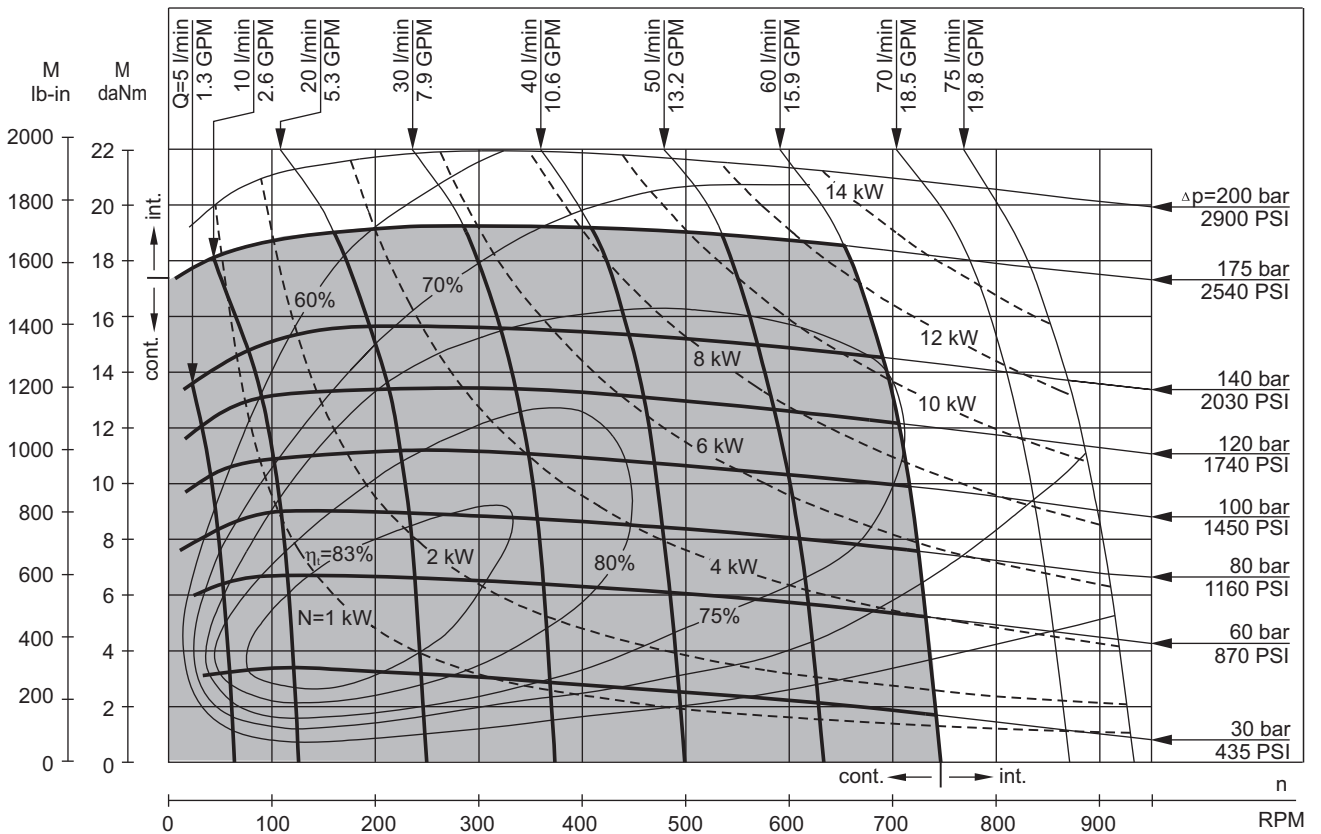

The function diagrams data is for average performance of randomly selected motors at back pressure 5÷10 bar [72.5 PSI÷145 PSI] and oil with viscosity of 32 mm²/s [150 SUS] at 50°C [122°F].

FUNCTION DIAGRAMS

RW 100

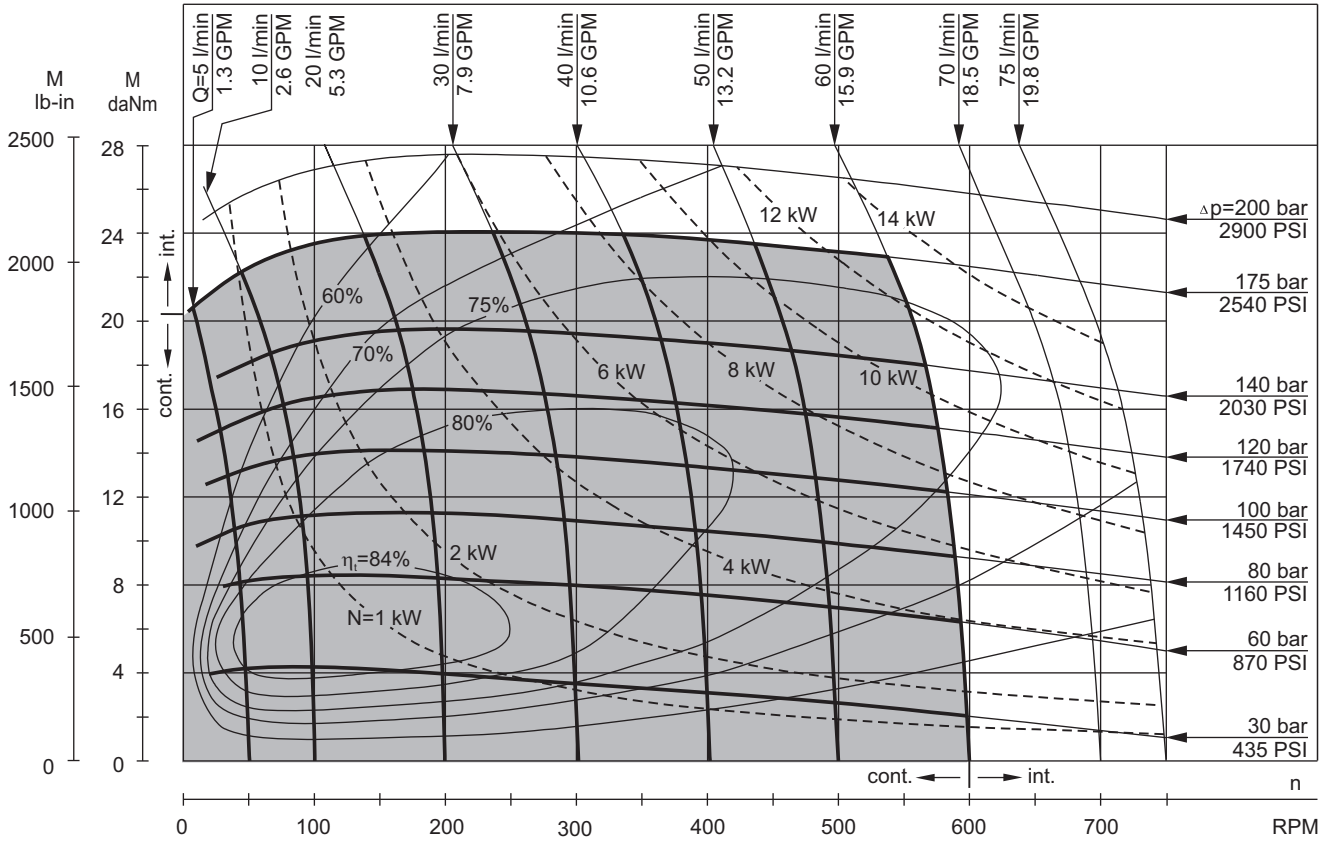

RW 125

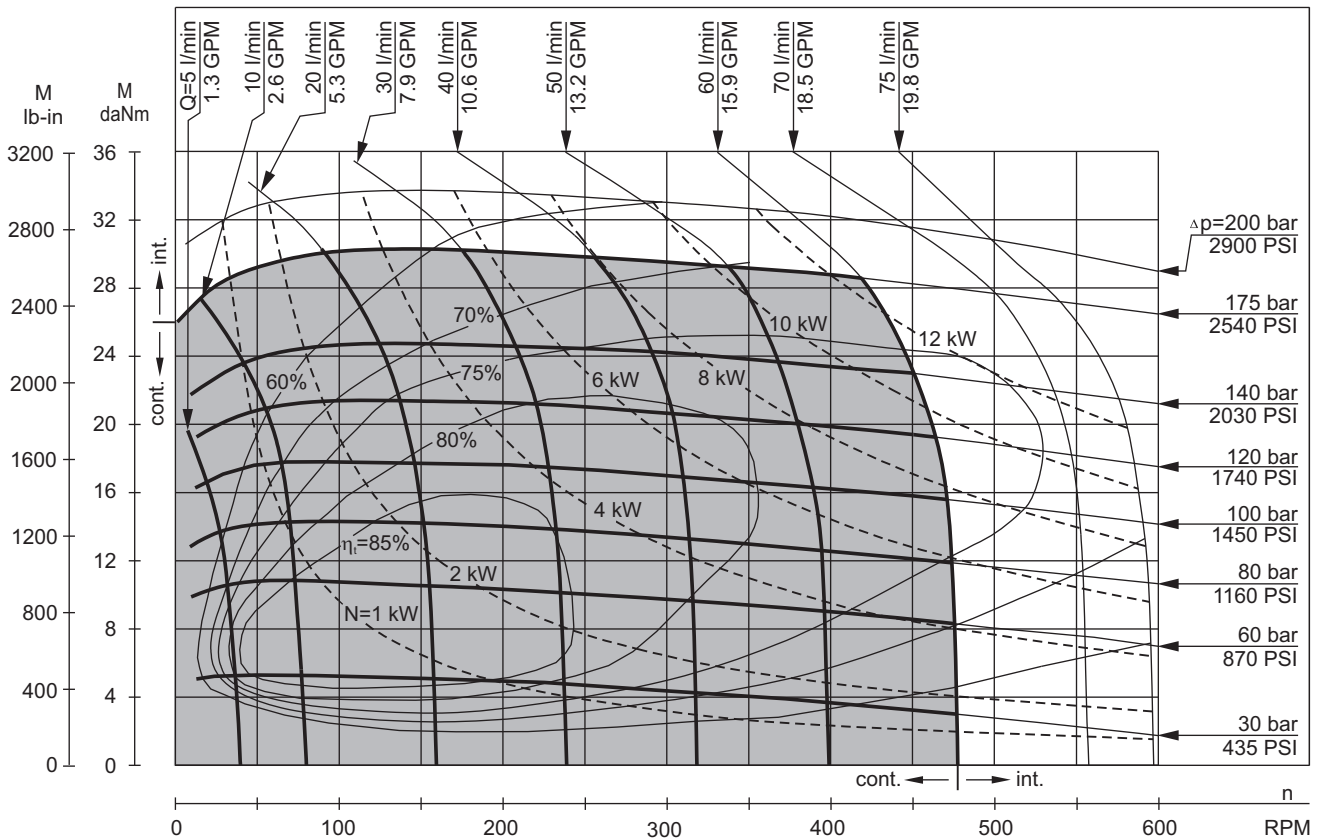

The function diagrams data is for average performance of randomly selected motors at back pressure 5÷10 bar [72.5 PSI÷145 PSI] and oil with viscosity of 32 mm²/s [150 SUS] at 50°C [122°F].

FUNCTION DIAGRAMS

RW 160

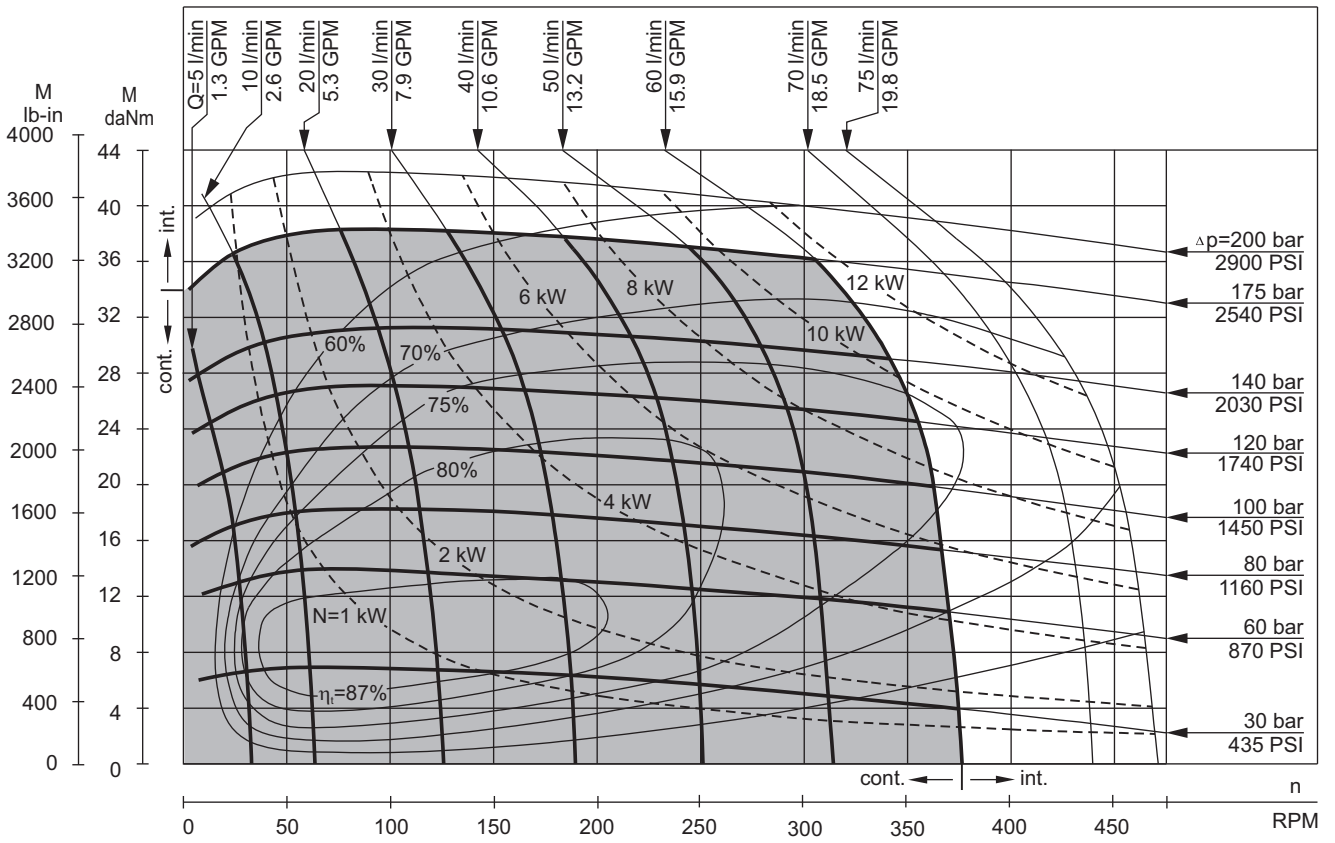

RW 200

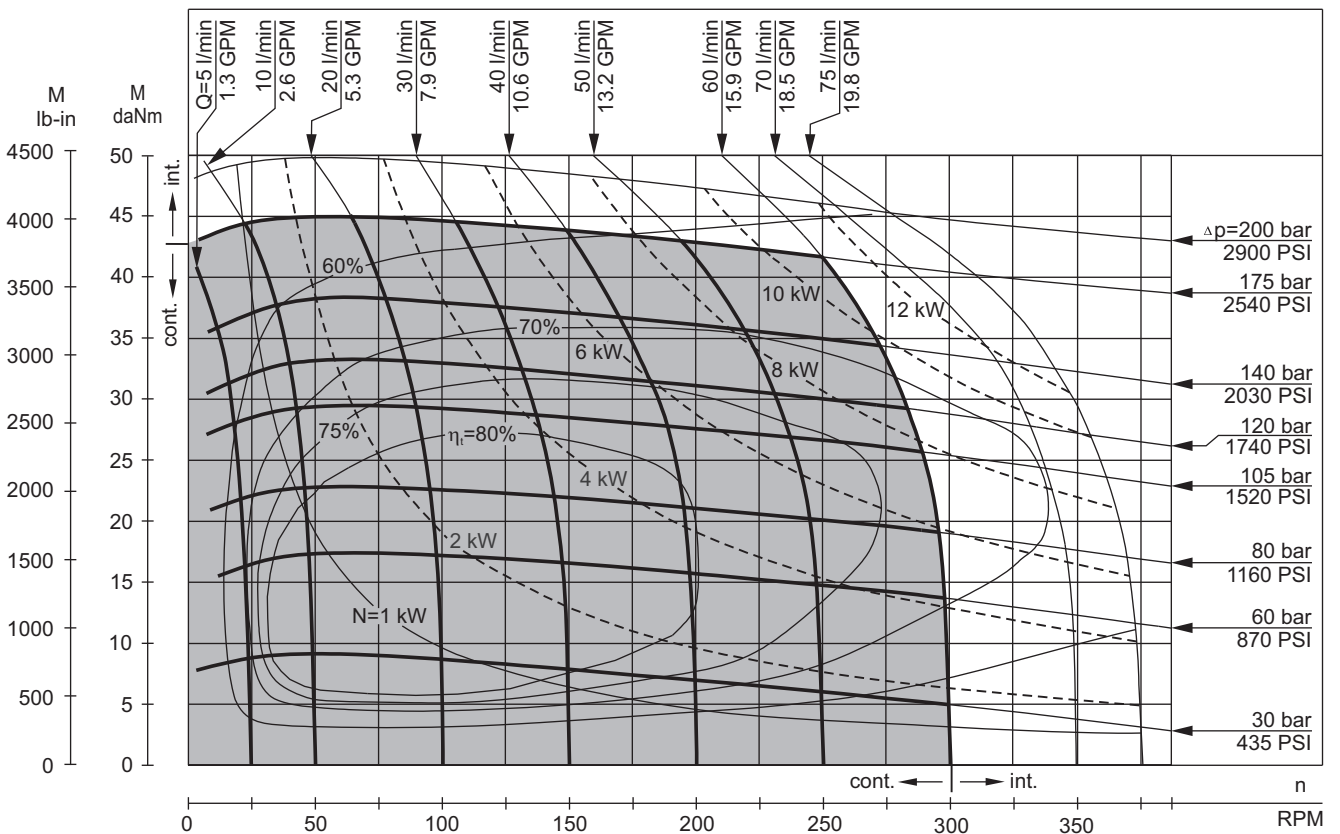

The function diagrams data is for average performance of randomly selected motors at back pressure 5÷10 bar [72.5 PSI÷145 PSI] and oil with viscosity of 32 mm²/s [150 SUS] at 50°C [122°F].

FUNCTION DIAGRAMS

RW 250

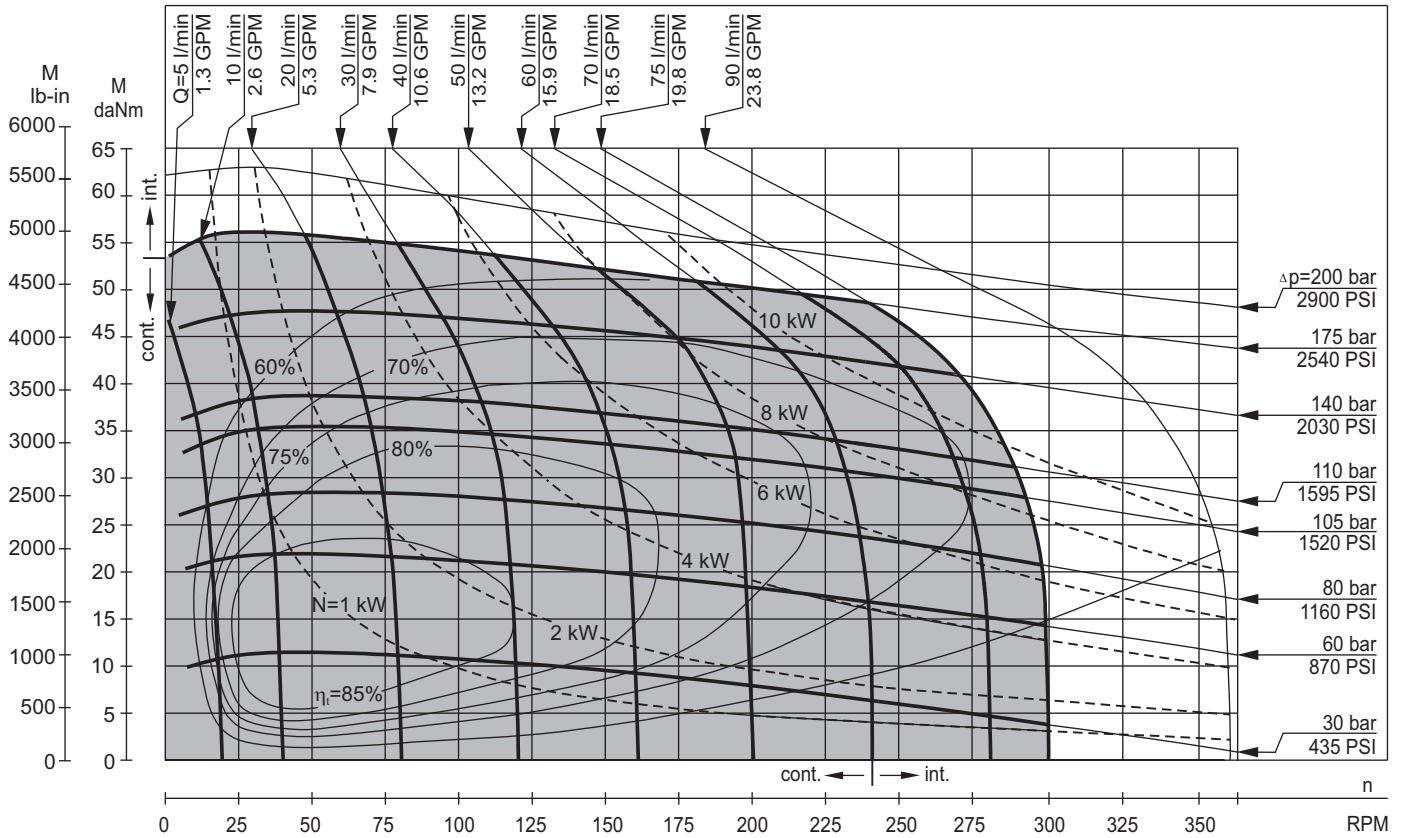

RW 315

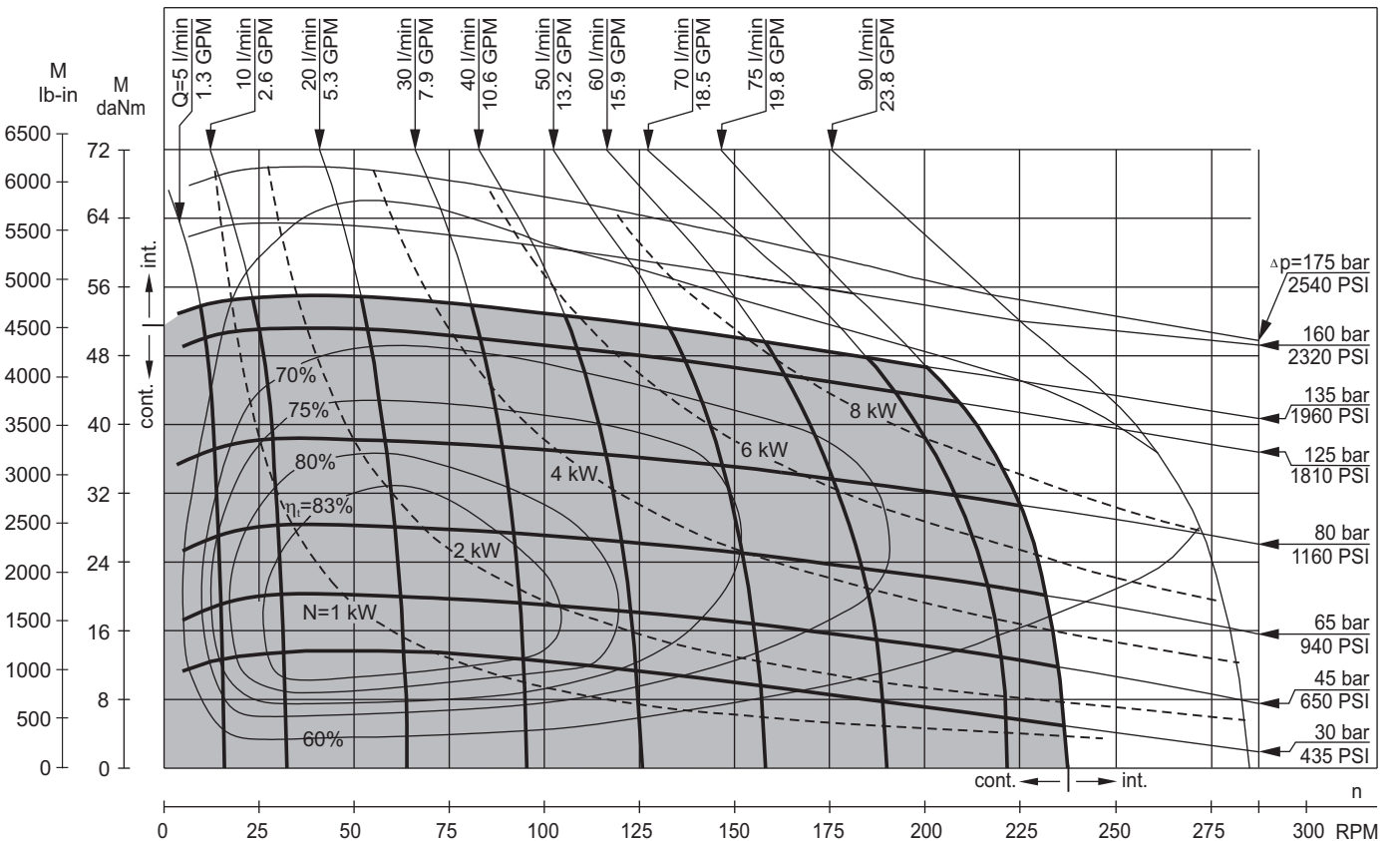

The function diagrams data is for average performance of randomly selected motors at back pressure 5÷10 bar [72.5 PSI÷145 PSI] and oil with viscosity of 32 mm²/s [150 SUS] at 50°C [122°F].

FUNCTION DIAGRAMS

RW 400

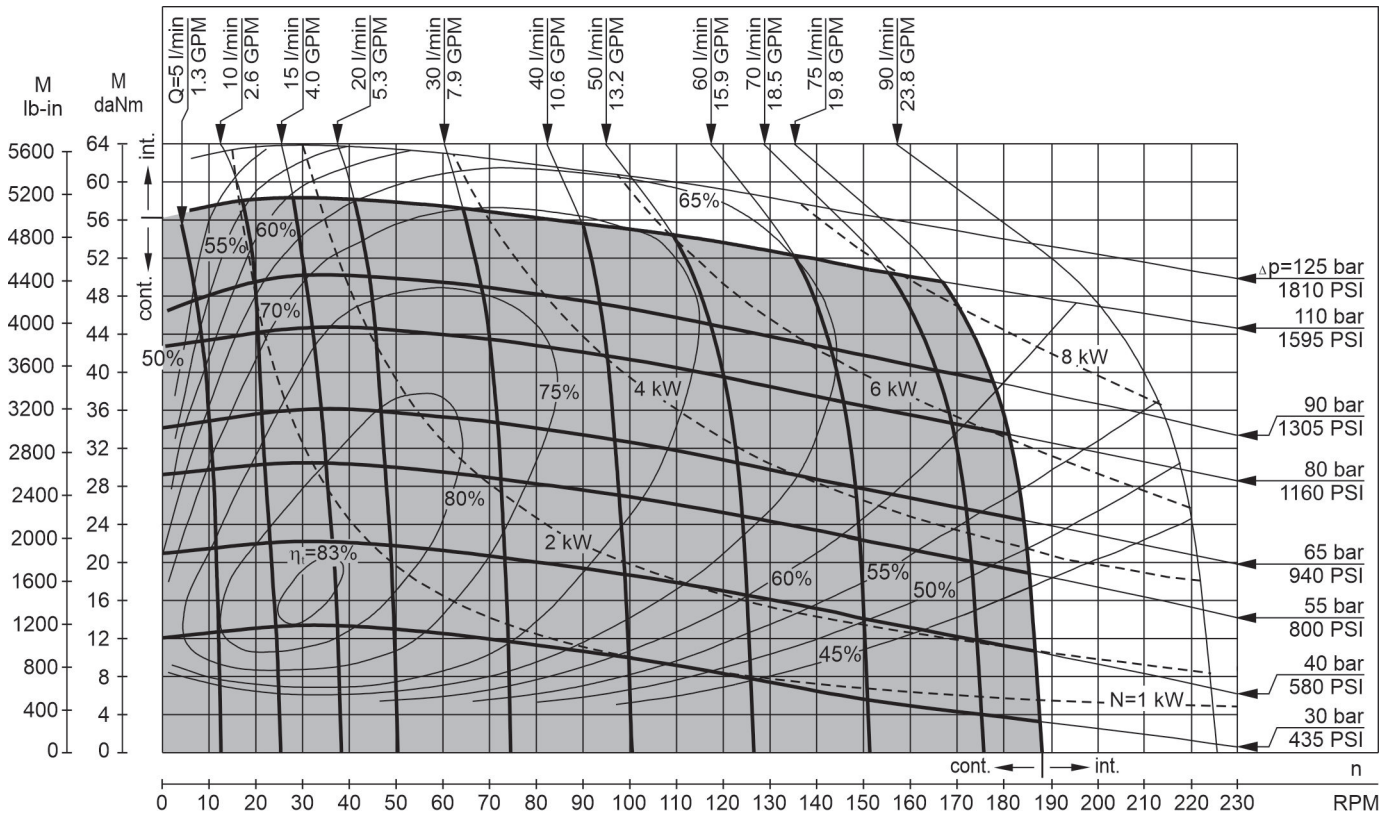

The function diagrams data is for average performance of randomly selected motors at back pressure 5÷10 bar [72.5 PSI÷145 PSI] and oil with viscosity of 32 mm²/s [150 SUS] at 50°C [122°F].

MAX. PERMISSIBLE SHAFT SEAL PRESSURE

RW...; RW...UK motors with drain connection:

The shaft seal pressure equals the pressure in the drain line.

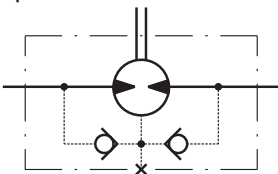

RW...1 motors without drain connection:

The shaft seal pressure never exceeds the pressure in the return line.

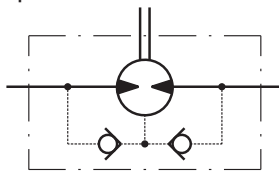

RW...U motors with high pressure seal and drain connection:

The shaft seal pressure equals the pressure in the drain line.

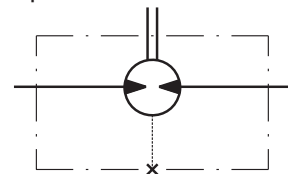

Max. return pressure without drain line or max. pressure in the drain line

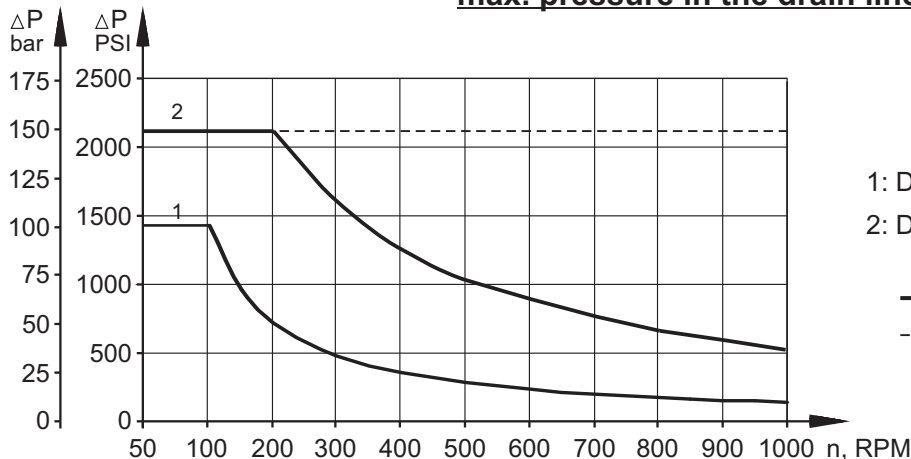

- 1: Drawing for Standard Shaft Seal
- 2: Drawing for High Pressure Seal ("U" Seal)
- - continuous operations
- - - - intermittent operations

DIMENSIONS and MOUNTING DATA

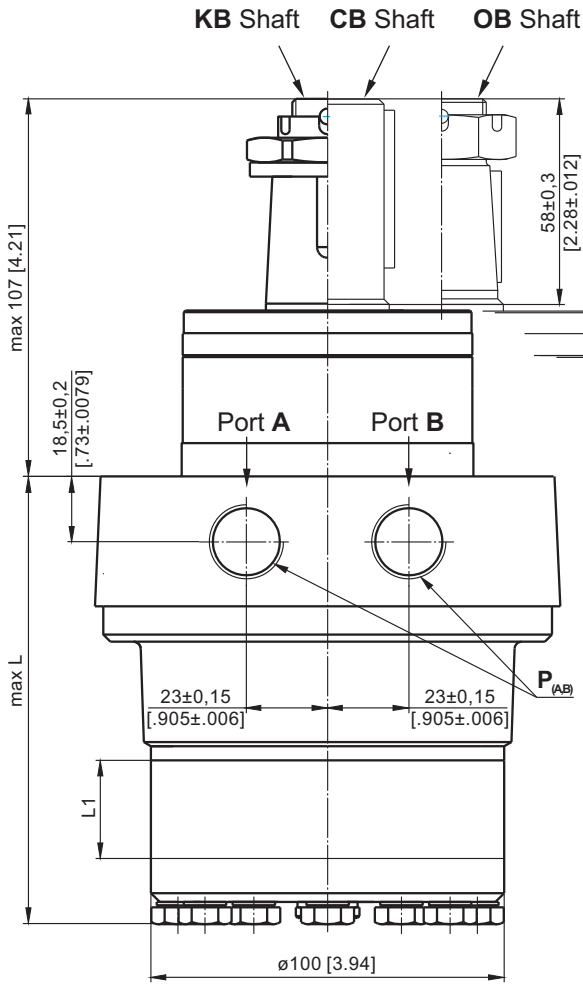

Shaft Dim.
See Page 92

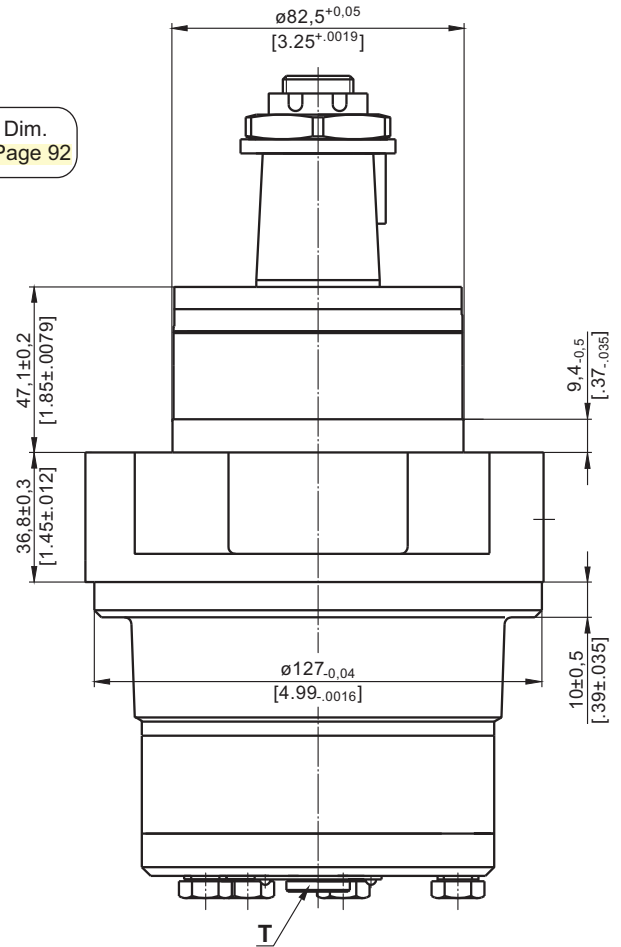

Type	L, mm [in]	L1, mm [in]
RW 50	108,0 [4.25]	9,0 [.35]
RW 80	113,0 [4.45]	14,0 [.55]
RW 100	116,5 [4.59]	17,4 [.69]
RW 125	120,5 [4.74]	21,8 [.86]
RW 160	126,5 [4.98]	27,8 [1.09]
RW 200	133,5 [5.26]	34,8 [1.37]
RW 250	142,5 [5.61]	43,5 [1.71]
RW 315	153,5 [6.04]	54,8 [2.16]
RW 400	168,5 [6.63]	69,4 [2.73]

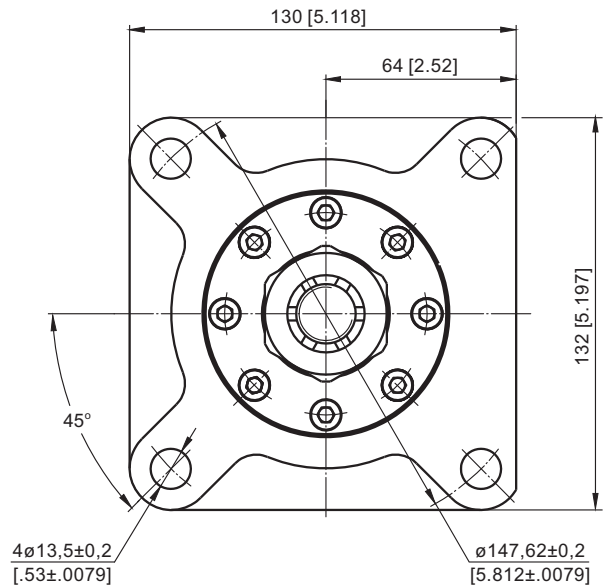

P_(A,B) : 2xG1/2 or 2xM22x1,5 - 17 mm [.67 in] depth
 T : G1/4 or M14x1,5 - 12 mm [.47 in] depth (plugged)

Standard Rotation
 Viewed from Shaft End
 Port A Pressurized - **CW**
 Port B Pressurized - **CCW**

Reverse Rotation
 Viewed from Shaft End
 Port A Pressurized - **CCW**
 Port B Pressurized - **CW**



SHAFT EXTENSIONS

CB - $\varnothing 32$ straight, Parallel key A10x8x45 DIN 6885
Max. Torque 77 daNm [6815 lb-in]

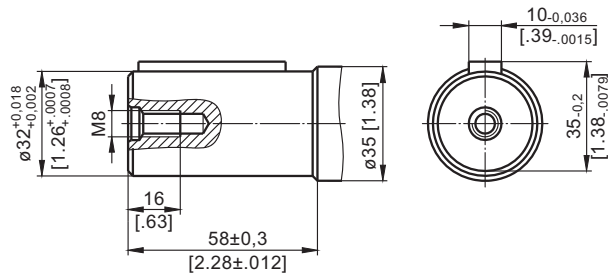

KB - tapered 1:10, Parallel key B6x6x20 DIN 6885
Max. Torque 95 daNm [8400 lb-in]

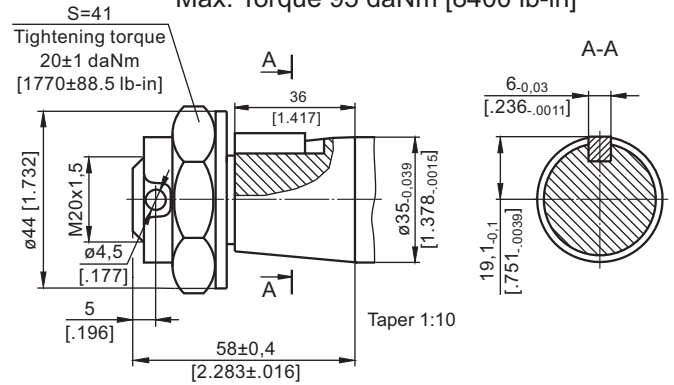

OB - tapered 1:8 SAEJ 501, Parallel key $\frac{5}{16} \times \frac{5}{16} \times \frac{1}{4}$ BS46
Max. Torque 77 daNm [6815 lb-in]

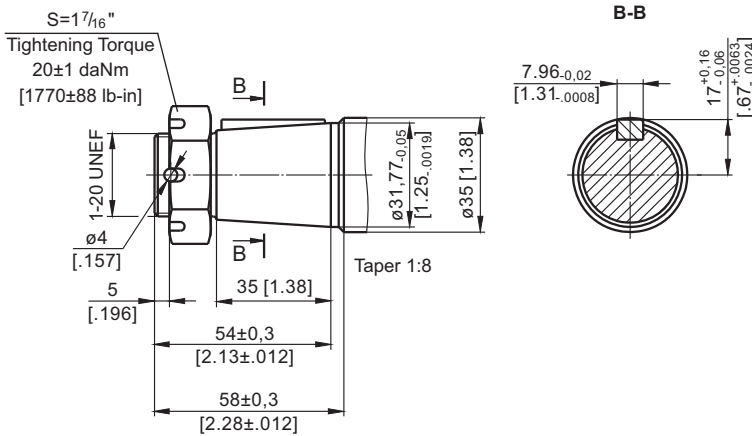

PERMISSIBLE SHAFT LOADS

The curve applies to a B10 bearing life of 2000 hours.

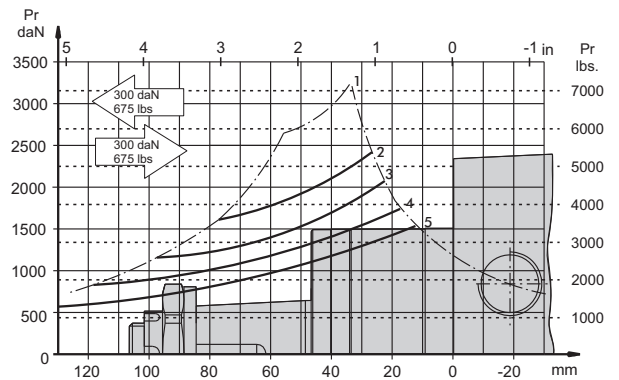

1. Permissible radial shaft load
2. Drawing by n= 50 rpm
3. Drawing by n=100 rpm
4. Drawing by n=200 rpm
5. Drawing by n=400 rpm

ORDER CODE

1	2	3	4	5	6	7
R W						

Pos.1 - Displacement code

50	- 51,5 cm ³ /rev [3.14 in ³ /rev]
80	- 80,3 cm ³ /rev [4.90 in ³ /rev]
100	- 99,8 cm ³ /rev [6.09 in ³ /rev]
125	- 125,7 cm ³ /rev [7.67 in ³ /rev]
160	- 159,6 cm ³ /rev [9.74 in ³ /rev]
200	- 199,8 cm ³ /rev [12.19 in ³ /rev]
250	- 250,1 cm ³ /rev [15.26 in ³ /rev]
315	- 315,7 cm ³ /rev [19.26 in ³ /rev]
400	- 397,0 cm ³ /rev [24.40 in ³ /rev]

Pos.2 - Shaft Extensions*

CB	- $\varnothing 32$ straight, Parallel key A10x8x45 DIN6885
KB	- $\varnothing 35$ tapered 1:10, Parallel key B6x6x20 DIN6888
OB	- $\varnothing 1\frac{1}{4}$ tapered 1:8, Parallel key $\frac{5}{16} \times \frac{5}{16} \times \frac{1}{4}$ BS46

Pos.3 - Shaft Seal Version

omit	- Standard shaft seal
U	- High pressure shaft seal without check valves
UK	- High pressure shaft seal with check valves

Pos.4 - Drain Port

omit	- with drain port
1	- without drain port

Pos.5 - Ports

omit	- BSPP (ISO 228)
M	- Metric (ISO 262)

Pos.6 - Additional Options (see page 125)

Pos.7 - Design Series

omit	- Factory specified
------	---------------------

NOTES: * The permissible output torque for shafts must not be exceeded!
The hydraulic motors are mangano-phosphatized as standard.

HYDRAULIC MOTORS MH

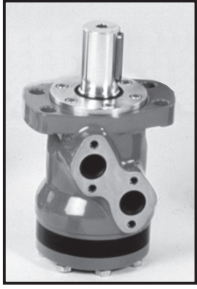

APPLICATION

- » Conveyors
- » Feeding mechanism of robots and manipulators
- » Metal working machines
- » Textile machines
- » Agricultural machines
- » Food industries
- » Mining machinery etc.

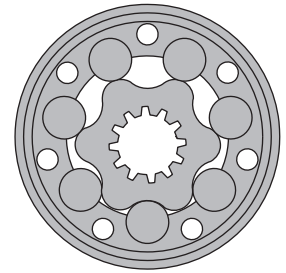

CONTENTS

Specification data	94
Function diagrams	95÷97
Permissible shaft loads	97
Dimensions and mounting	98
Permissible shaft seal pressure	99
Tacho connection	99
Shaft extensions	100
Order code	100

OPTIONS

- » Model - Spool valve, roll-gerotor
- » Flange mount
- » Shafts - straight, splined and tapered
- » Metric and BSPP ports
- » Other special features

GENERAL

Max. Displacement, cm ³ /rev [in ³ /rev]	502,4 [30.7]
Max. Speed, [RPM]	445
Max. Torque, daNm [lb-in]	cont.: 84 [7434] int.: 104 [9204]
Max. Output, kW [HP]	18,5 [24.8]
Max. Pressure Drop, bar [PSI]	cont.: 175 [2540] int.: 200 [2900]
Max. Oil Flow, lpm [GPM]	90 [23.78]
Min. Speed, [RPM]	5
Pressure fluid	Mineral based- HLP(DIN 51524) or HM(ISO 6743/4)
Temperature range, °C [°F]	-40÷140 [-40÷284]
Optimal Viscosity range, mm²/s [SUS]	20÷75 [98÷347]
Filtration	ISO code: 18/16/13 According to ISO 4406-1999

Oil flow in drain line

Pressure drop bar [PSI]	Viscosity mm ² /s [SUS]	Oil flow in drain line lpm [GPM]
100 [1450]	20 [98]	2,5 [.660]
	35 [164]	1,8 [.476]
140 [2030]	20 [98]	3,5 [.925]
	35 [164]	2,8 [.740]

Pressure Losses

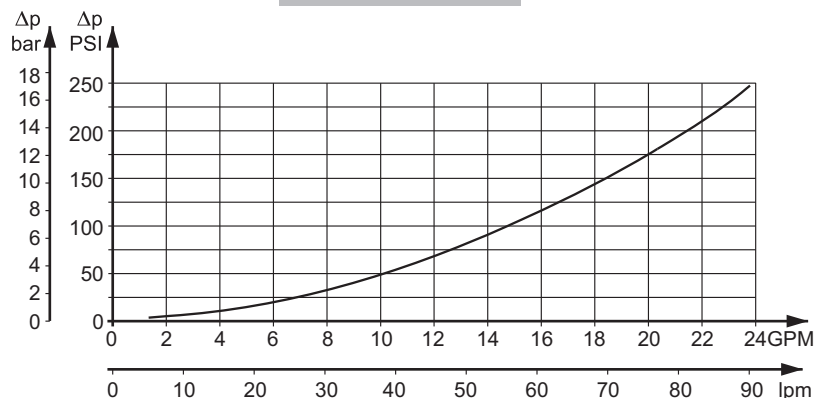

SPECIFICATION DATA

Type		MH 200	MH 250	MH 315	MH 400	MH 500
Displacement, cm³/rev [in³/rev]		201,3 [12.3]	252 [15.4]	314,9 [19.2]	396,8 [24.2]	502,4 [30.7]
Max. Speed, [RPM]	Cont.	370	295	235	185	150
	Int.*	445	350	285	225	180
Max. Torque daNm [lb-in]	Cont.	51 [4510]	61 [5398]	74 [6548]	84 [7434]	82 [7257]
	Int.*	58 [5130]	70 [6195]	82 [7257]	98 [8673]	104 [9204]
	Peak**	64 [5064]	79 [6992]	98 [8673]	109 [9647]	117 [10350]
Max. Output kW [HP]	Cont.	16 [21]	16 [21]	14 [18.7]	12,5 [16.7]	11 [14.7]
	Int.*	18,5 [24.8]	18,5 [24.8]	15,5 [20.7]	15 [20.1]	14 [18.7]
Max. Pressure Drop bar [PSI]	Cont.	175 [2540]	175 [2540]	175 [2540]	155 [2240]	125 [1810]
	Int.*	200 [2900]	200 [2900]	200 [2900]	190 [2750]	160 [2320]
	Peak**	225 [3260]	225 [3260]	225 [3260]	210 [3045]	180 [2610]
Max. Oil Flow lpm [GPM]	Cont.	75 [19.81]	75 [19.81]	75 [19.81]	75 [19.81]	75 [19.81]
	Int.*	90 [23.78]	90 [23.78]	90 [23.78]	90 [23.78]	90 [23.78]
Max. Inlet Pressure bar [PSI]	Cont.	200 [2900]	200 [2900]	200 [2900]	200 [2900]	200 [2900]
	Int.*	225 [3260]	225 [3260]	225 [3260]	225 [3260]	225 [3260]
	Peak**	250 [3626]	250 [3626]	250 [3626]	250 [3626]	250 [3626]
Max. Starting Pressure with Unloaded Shaft, bar [PSI]		5 [72]	5 [72]	5 [72]	5 [72]	5 [72]
Min. Starting Torque, daNm [lb-in]	At max.press.dropCont	39 [3450]	52 [4600]	66 [5840]	72 [6370]	72 [6370]
	At max.press.drop Int.*	45 [3980]	59 [5221]	73 [6460]	88 [7788]	88 [7788]
Min. Speed***, [RPM]		10	10	8	5	5
Weight, kg [lb]		10,5 [23.2]	11 [24.3]	11,5 [25.4]	12,3 [27.1]	13 [28.7]

* Intermittent operation: the permissible values may occur for max. 10% of every minute.

** Peak load: the permissible values may occur for max. 1% of every minute.

*** For speeds lower than given, consult factory or your regional manager.

- Intermittent speed and intermittent pressure must not occur simultaneously.
- Recommended filtration is per ISO cleanliness code 20/16. A nominal filtration of 25 micron or better.
- Recommend using a premium quality, anti-wear type mineral based hydraulic oil HLP(DIN51524) or HM (ISO 6743/4).
If using synthetic fluids consult the factory for alternative seal materials.
- Recommended minimum oil viscosity 13 mm²/s [70 SUS] at 50°C [122°F].
- Recommended maximum system operating temperature is 82°C [180°F].
- To assure optimum motor life fill with fluid prior to loading and run at moderate load and speed for 10-15 minutes.

FUNCTION DIAGRAMS

MH 200

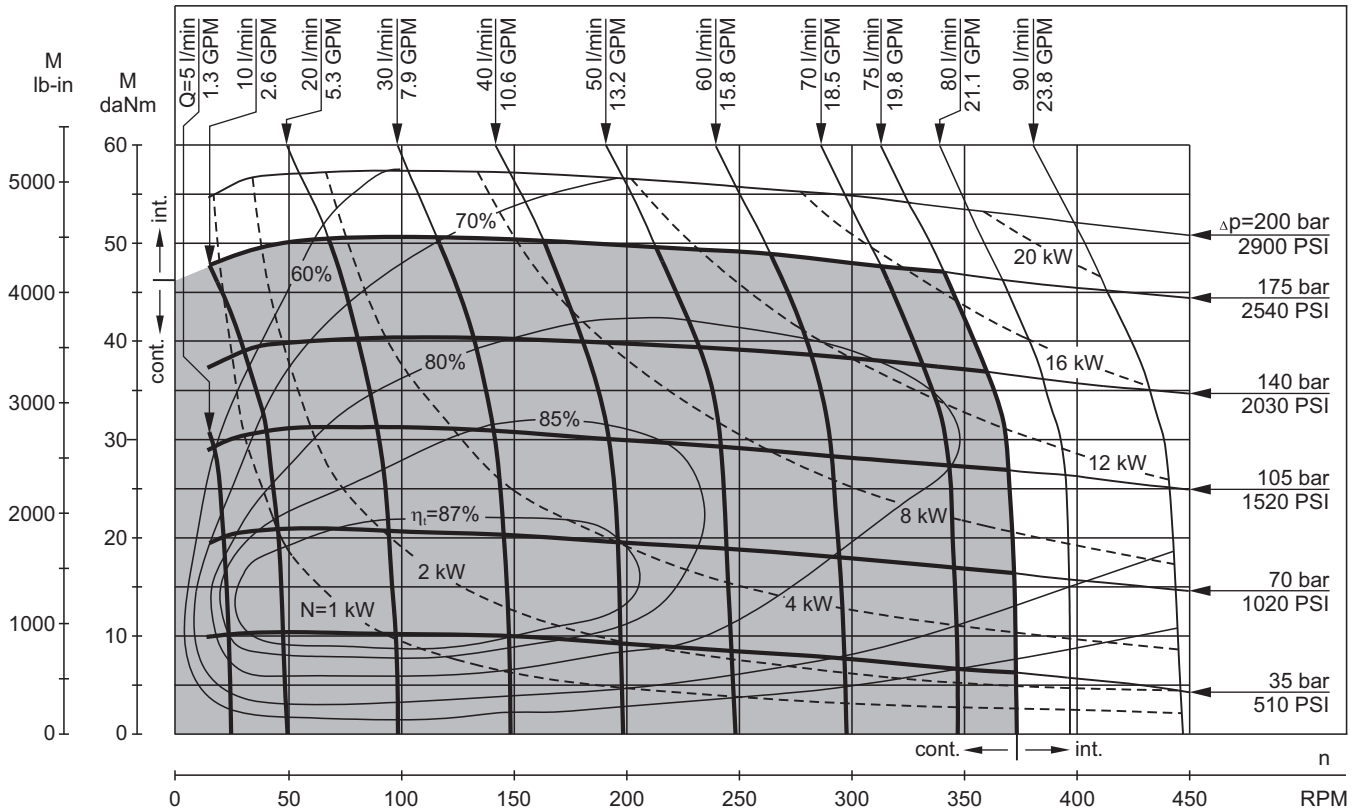

MH 250

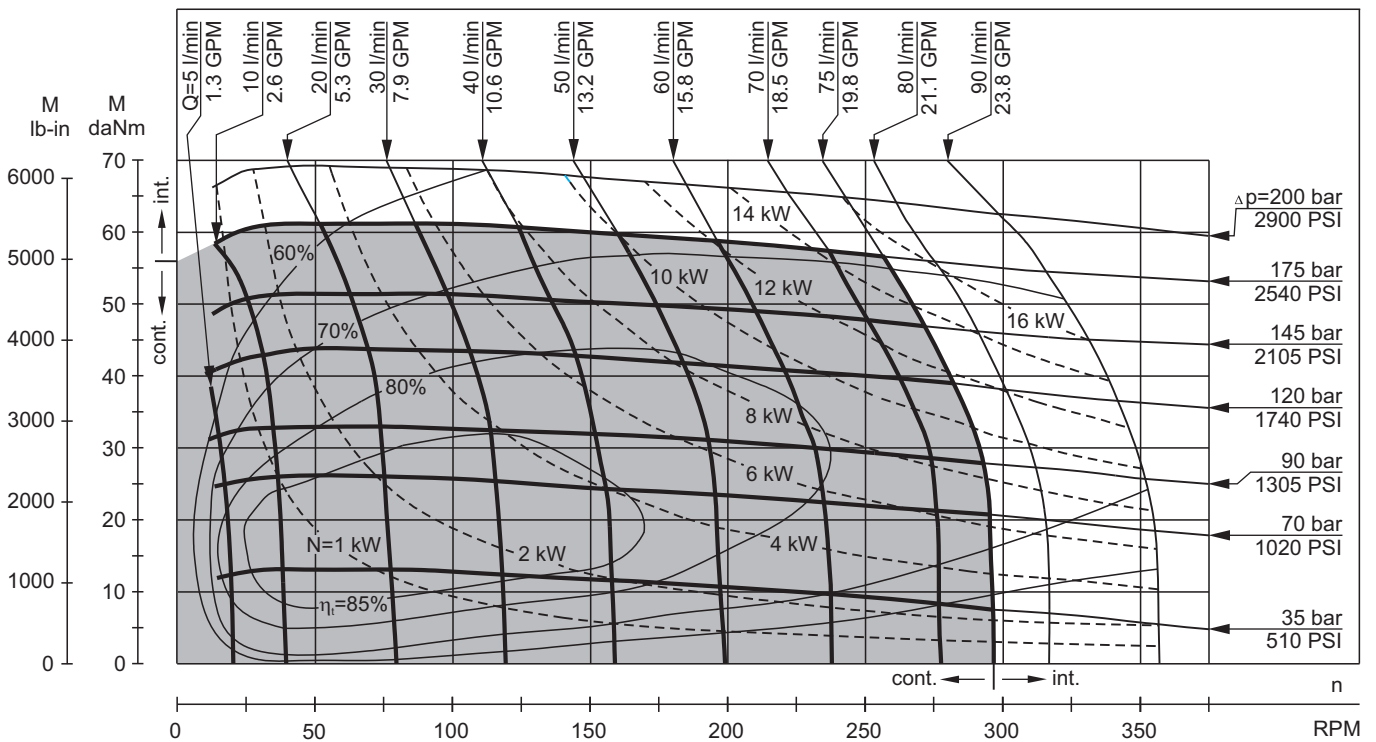

The function diagrams data is for average performance of randomly selected motors at back pressure 5÷10 bar [72.5 PSI÷145 PSI] and oil with viscosity of 32 mm²/s [150 SUS] at 50°C [122°F].

FUNCTION DIAGRAMS

MH 315

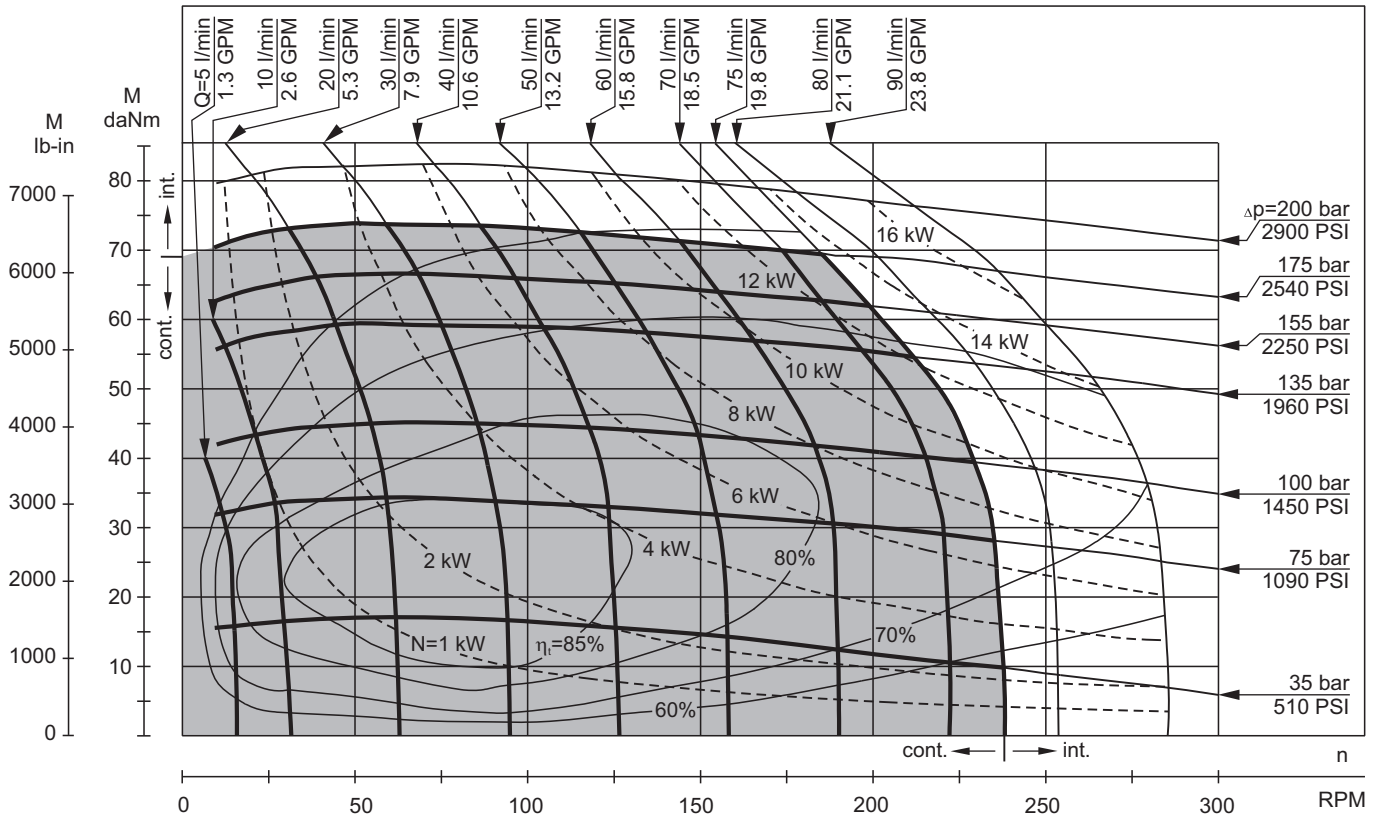

MH 400

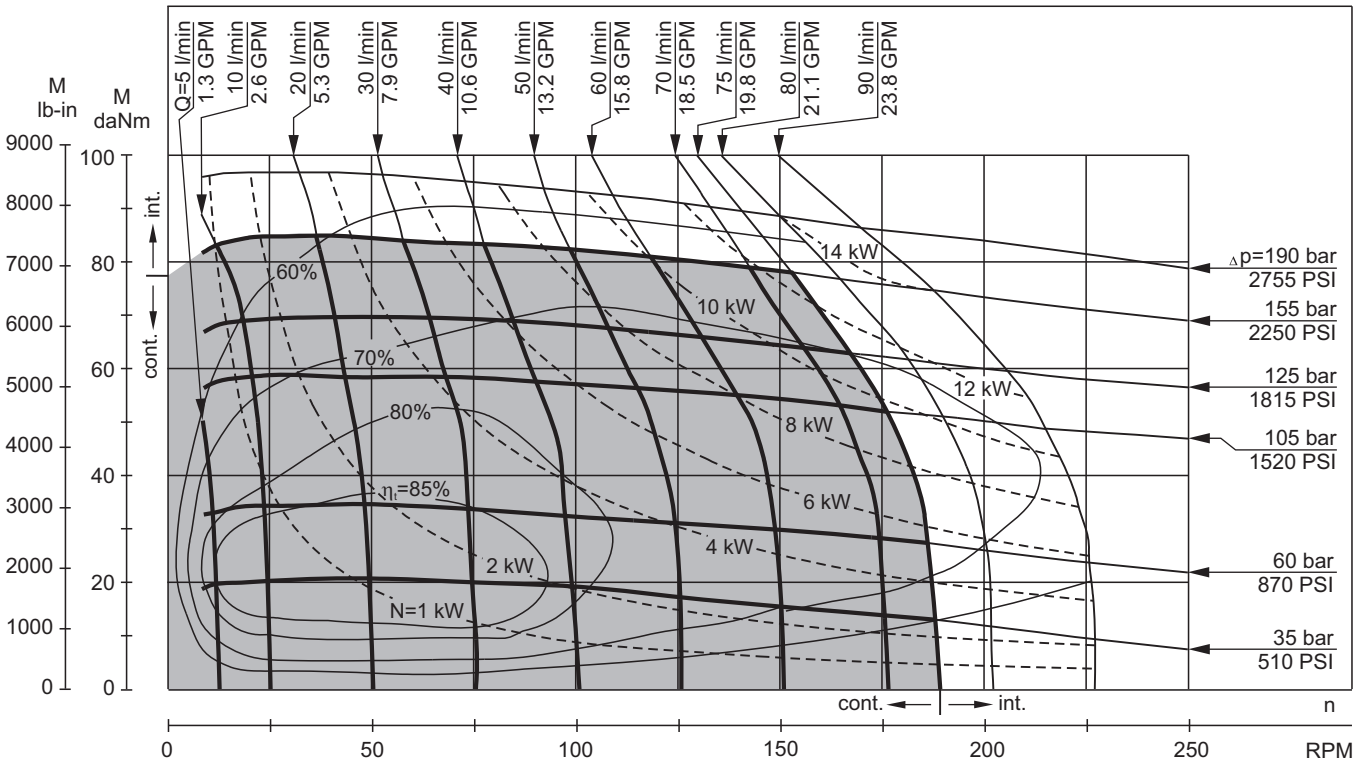

The function diagrams data is for average performance of randomly selected motors at back pressure 5÷10 bar [72.5 PSI÷145 PSI] and oil with viscosity of 32 mm²/s [150 SUS] at 50°C [122°F].

FUNCTION DIAGRAMS

MH 500

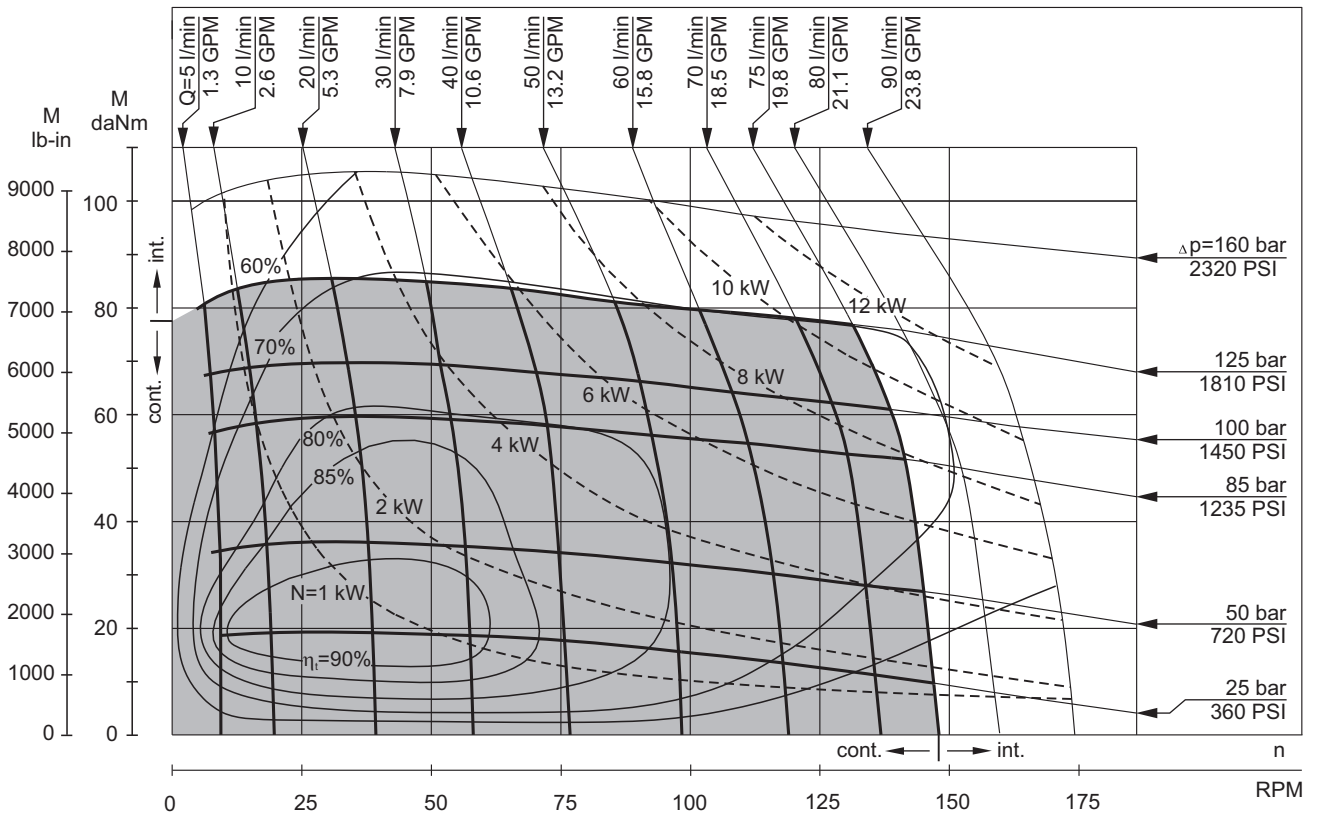

The function diagrams data is for average performance of randomly selected motors at back pressure 5±10 bar [72.5 PSI±145 PSI] and oil with viscosity of 32 mm²/s [150 SUS] at 50°C [122°F].

PERMISSIBLE SHAFT LOADS for MH MOTORS

The permissible radial shaft load P_{rad} depends on the speed (RPM) and distance (L) from the point of load to the mounting flange.

$$\text{Radial Shaft Load } P_{rad} = \frac{1100}{n} \times \frac{25000}{103,5+L}, \text{ daN}^*$$

[*L in mm; L ≤ 60 mm; n ≥ 200 RPM]

$$\text{Radial Shaft Load } P_{rad} = \frac{1100}{\text{RPM}} \times \frac{2215}{4.075+L}, \text{ lbs}^{**}$$

[**L in inch; L ≤ 2.36 in; n ≥ 200 RPM]

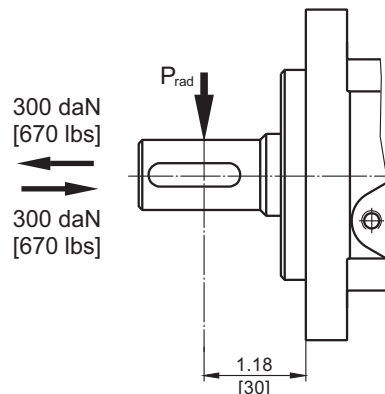
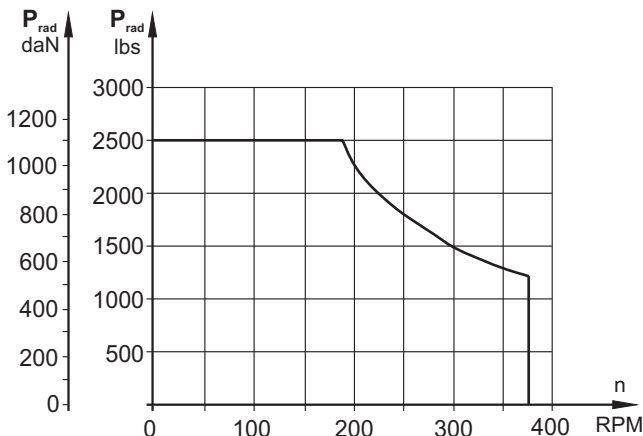

DIMENSIONS and MOUNTING DATA

Magneto mount (4 holes)

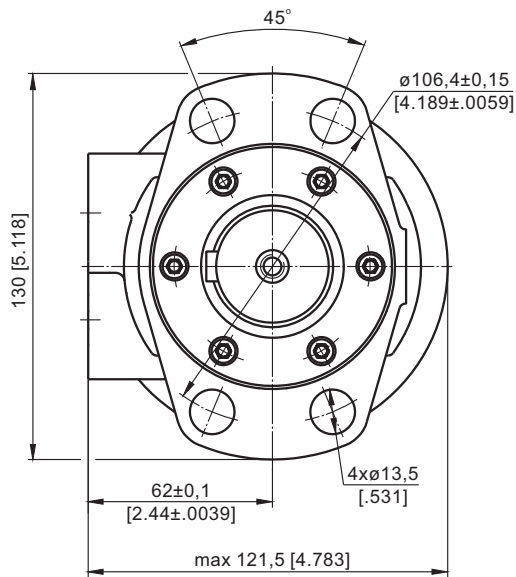
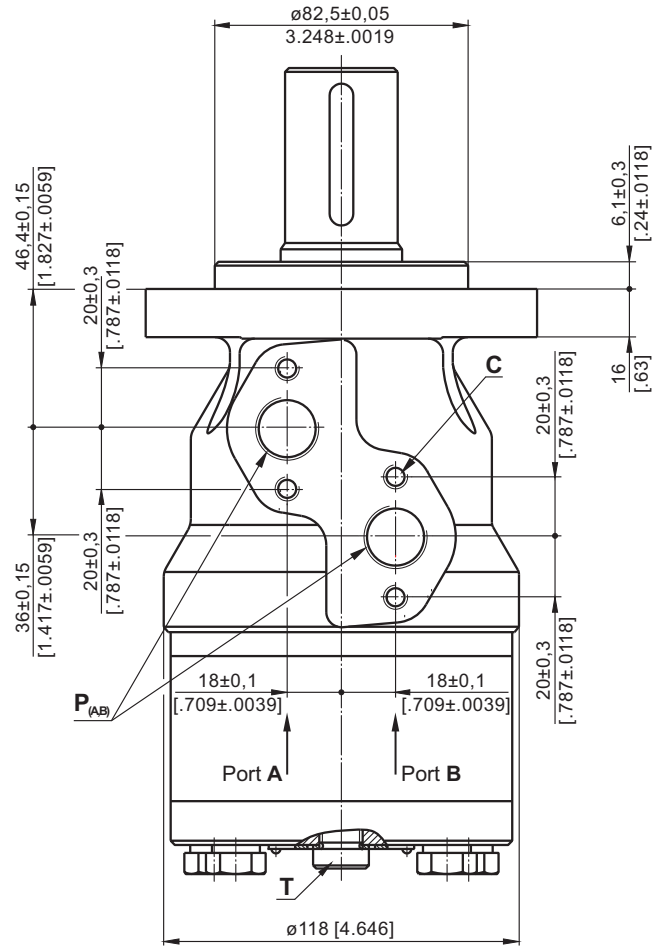
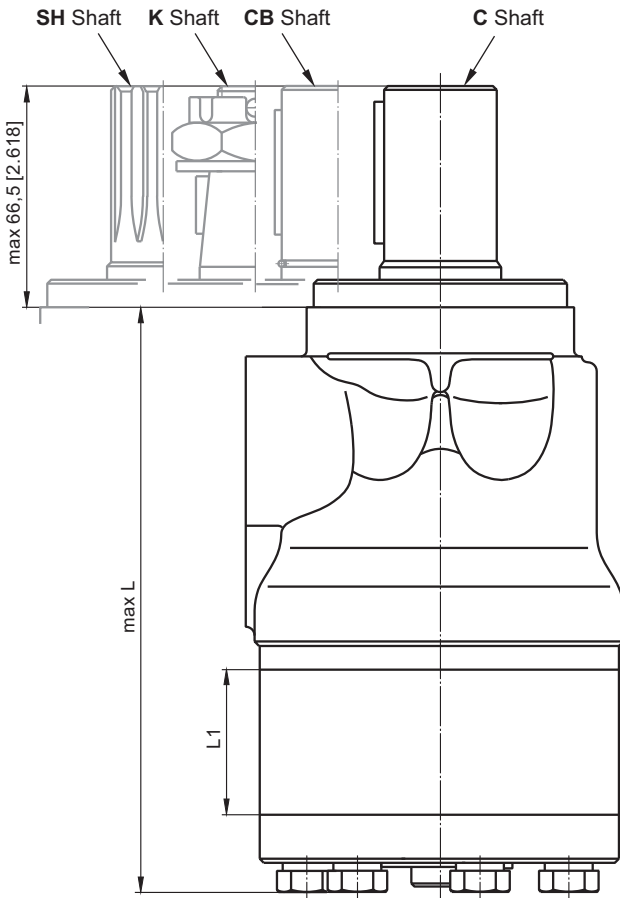

Type	L, mm [in]	L ₁ , mm [in]
MH 200	169 [6.65]	27,8 [1.09]
MH 250	176 [6.93]	34,8 [1.37]
MH 315	184 [7.24]	43,5 [1.71]
MH 400	196 [7.72]	54,8 [2.16]
MH 500	211 [8.31]	69,4 [2.73]

- C** : 4xM8-13 mm [.51 in] depth
P_(A,B) : 2xG1/2 or 2xM22x1,5-15 mm [.59 in] depth
T : G1/4 or M14x1,5-12 mm [.47 in] depth (plugged)

Standard Rotation
 Viewed from Shaft End
 Port A Pressurized - **CW**
 Port B Pressurized - **CCW**

Reverse Rotation
 Viewed from Shaft End
 Port A Pressurized - **CCW**
 Port B Pressurized - **CW**



MAX. PERMISSIBLE SHAFT SEAL PRESSURE for MH MOTORS

MH...U1 motors with high pressure seal and without drain connection:

The shaft seal pressure equals the average of input pressure and return pressure.

$$P_{\text{seal}} = \frac{P_{\text{input}} + P_{\text{return}}}{2}$$

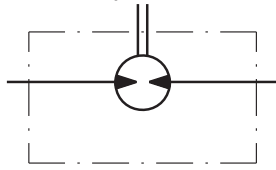

MH...U motors with high pressure seal and drain connection:

The shaft seal pressure equals the pressure in the drain line.

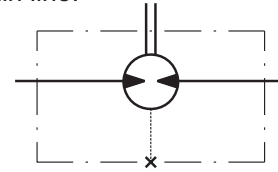

MH...1 motors with standard shaft seal and without drain connection:

The shaft seal pressure never exceeds the pressure in the return line.

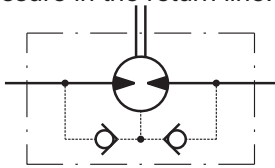

MH... motors with standard shaft seal and with drain connection:

The shaft seal pressure equals the pressure in the drain line.

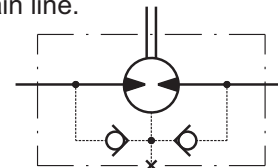

Max. return pressure without drain line or max. pressure in the drain line

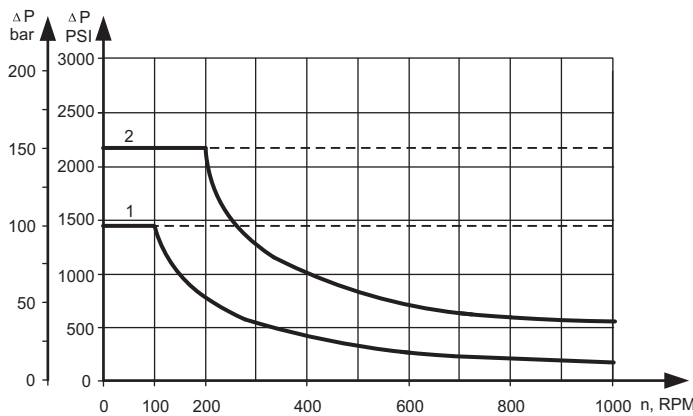

1: Drawing for Standard Shaft Seal

2: Drawing for High Pressure Seal ("U" Seal)

— - continuous operations
- - - - intermittent operations

MOTORS with TACHO CONNECTION

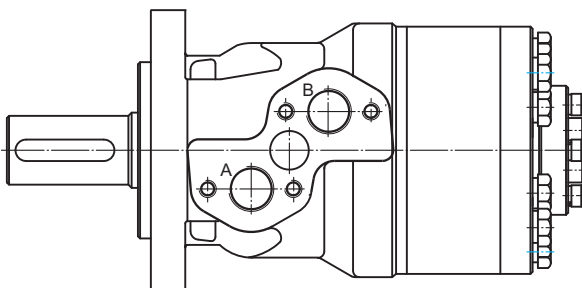
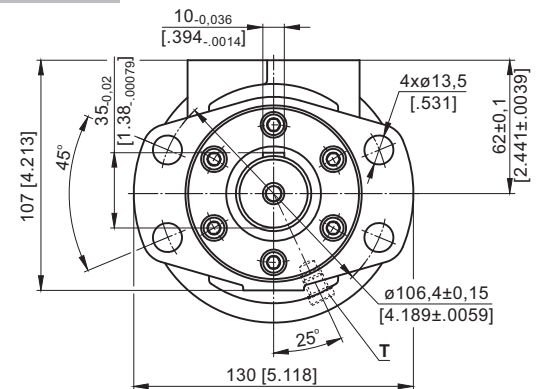
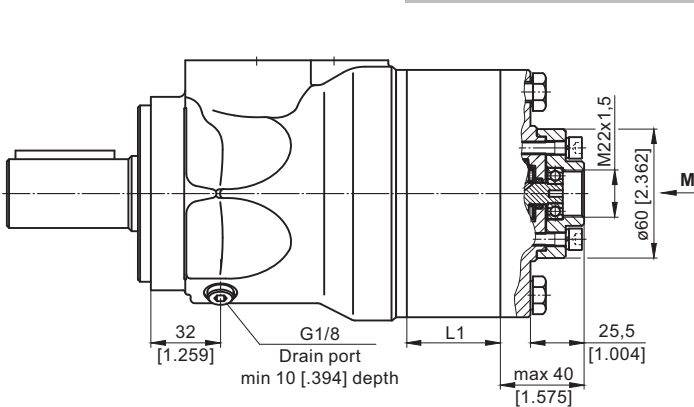

Type	L, mm [in]	L ₁ , mm [in]
MH 200	191 [7.52]	27,8 [1.09]
MH 250	198 [7.79]	34,8 [1.37]
MH 315	207 [8.15]	43,5 [1.71]
MH 400	218 [8.58]	54,8 [2.16]
MH 500	233 [9.17]	69,4 [2.73]

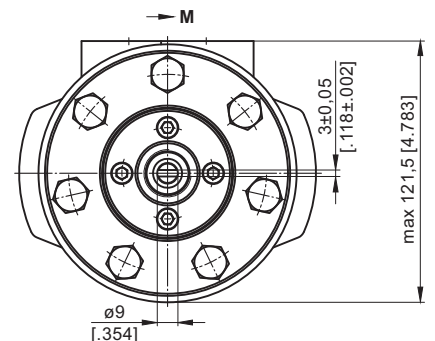

SHAFT EXTENSIONS

C - $\varnothing 32$ straight, Parallel key A10x8x45 DIN 6885
Max. Torque 77 daNm [6815 lb-in]

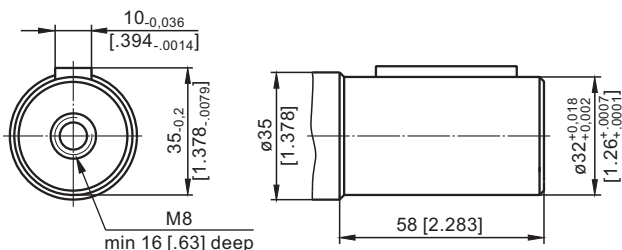

SH - $\varnothing 1\frac{1}{4}$ " splined 14T, DP 12/24 ANSI B92.1-1976
Max. Torque 95 daNm [8400 lb-in]

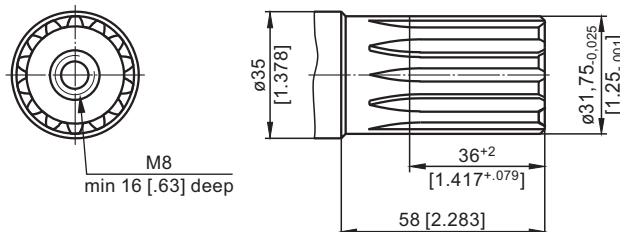

CB - $\varnothing 35$ straight, Parallel key A10x8x45 DIN 6885
Max. Torque 95 daNm [8400 lb-in]

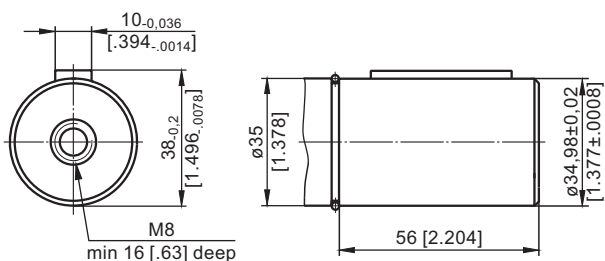

K - tapered 1:10, Parallel key B6x6x20 DIN 6885
Max. Torque 95 daNm [8400 lb-in]

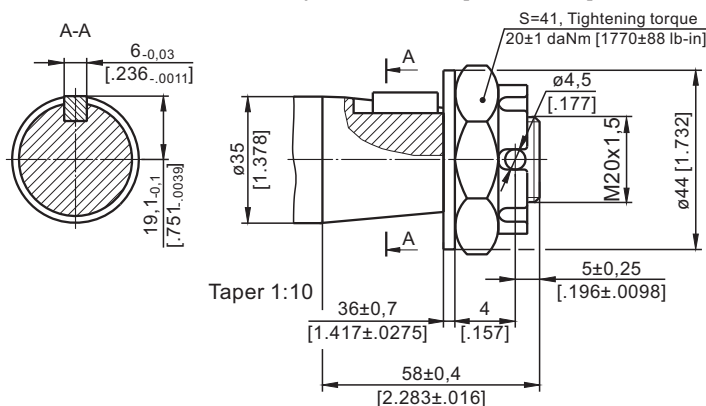

ORDER CODE

	1	2	3	4	5	6	7
MH							

Pos.1 - Displacement code

200	- 201,3 cm ³ /rev [12.3 in ³ /rev]
250	- 252,0 cm ³ /rev [15.4 in ³ /rev]
315	- 314,9 cm ³ /rev [16.4 in ³ /rev]
400	- 396,8 cm ³ /rev [24.2 in ³ /rev]
500	- 502,4 cm ³ /rev [30.7 in ³ /rev]

Pos.2 - Shaft Extensions*

C	- $\varnothing 32$ straight, Parallel key A10x8x45 DIN6885
SH	- $\varnothing 1\frac{1}{4}$ " splined 14T ANSI B92.1-1970
CB**	- $\varnothing 35$ straight, Parallel key A10x8x45 DIN6885
K	- $\varnothing 35$ tapered 1:10, Parallel key B6x6x20 DIN6885

Pos.3 - Shaft Seal Version

omit	- Standard shaft seal
U	- High pressure shaft seal (without check valves)

Pos.4 - Drain Port

omit	- with drain port
1	- without drain port

Pos.5 - Ports

omit	- BSPP (ISO 228)
M	- Metric (ISO 262)

Pos.6 - Additional Options (see page 125)

Pos.7 - Design Series

omit	- Factory specified
------	---------------------

NOTES: * The permissible output torque for shafts must not be exceeded!
** The following combination is not allowed: "CB" shaft with U shaft seal.

The hydraulic motors are manganophosphatized as standard.

HYDRAULIC MOTORS HW



APPLICATION

- » Conveyors
- » Feeding mechanism of robots and manipulators
- » Metal working machines
- » Textile machines
- » Agricultural machines
- » Food industries
- » Grass cutting machinery etc.

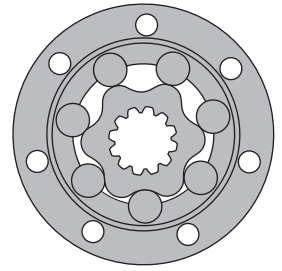

CONTENTS

Specification data	102÷104
Function diagrams	105÷113
Permissible shaft seal pressure	113
Dimensions and mounting	114÷119
Permissible shaft loads	120
Shaft extensions	120÷122
Order code	123

OPTIONS

- » Model - Spool valve, roll-gerotor
- » Wheel and flange mount
- » Shafts - straight, splined and tapered
- » BSPP and SAE ports
- » Other special features

GENERAL

Max. Displacement, cm ³ /rev [in ³ /rev]	753,8 [45.99]
Max. Speed, [RPM]	750
Max. Torque, daNm [lb-in]	cont.: 96 [8500] int.: 106 [9382]
Max. Output, kW [HP]	23,1 [31]
Max. Pressure Drop, bar [PSI]	cont.: 205 [3000] int.: 225 [3260]
Max. Oil Flow, lpm [GPM]	115 [30.4]
Min. Speed, [RPM]	10
Pressure fluid	Mineral based- HLP(DIN 51524) or HM(ISO 6743/4)
Temperature range, °C [°F]	-40÷140 [-40÷284]
Optimal Viscosity range, mm ² /s [SUS]	20÷75 [98÷347]
Filtration	ISO code: 18/16/13 According to ISO 4406-1999

Oil flow in drain line

Pressure drop bar [PSI]	Viscosity mm ² /s [SUS]	Oil flow in drain line lpm [GPM]
100 [1450]	20 [98]	2,5 [.660]
	35 [164]	1,8 [.476]
140 [2030]	20 [98]	3,5 [.925]
	35 [164]	2,8 [.740]

Pressure Losses

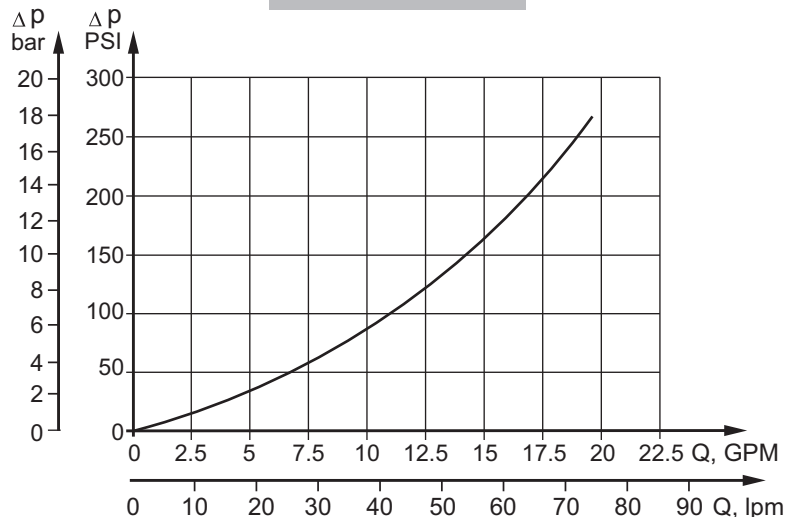

SPECIFICATION DATA

Type		HW 80	HW 100	HW 125	HW 160	HW 200	HW 235
Displacement, cm³/rev [in³/rev]		79,7 [4.86]	101,4 [6.19]	126 [7.69]	157,8 [9.63]	201,3 [12.28]	235,3 [14.36]
Max. Speed, [RPM]	Cont.	565	445	357	380	373	319
	Int.*	750	590	476	475	497	425
Max. Torque, daNm [lb-in]	Cont.	18,8 [1664]	24 [2124]	35 [3098]	44 [3894]	55 [4868]	64,5 [5710]
	Int.*	22,1 [1956]	28,2 [2496]	38,5 [3408]	48 [4248]	60 [5310]	70 [6196]
Max. Output, kW [HP]	Cont.	15,4 [20.7]	15,8 [21.2]	16,2 [21.7]	17,6 [23.6]	18,6 [24.9]	18,2 [24.4]
	Int.*	17,4 [23.3]	18,1 [24.3]	19,8 [26.6]	21,6 [29]	23,1 [31]	22,6 [30.3]
Max. Pressure Drop, bar [PSI]	Cont.	175 [2540]	175 [2540]	205 [2970]	205 [2970]	205 [2970]	205 [2970]
	Int.*	205 [2970]	205 [2970]	225 [3260]	225 [3260]	225 [3260]	225 [3260]
Max. Oil Flow, lpm [GPM]	Cont.	45 [12]	45 [12]	45 [12]	60 [16]	75 [20]	75 [20]
	Int.*	60 [16]	60 [16]	60 [16]	75 [20]	100 [26.4]	100 [26.4]
Max. Inlet Pressure, bar [PSI]	Cont.	200 [2900]	200 [2900]	210 [3050]	210 [3050]	210 [3050]	210 [3050]
	Int.*	225 [3260]	225 [3260]	250 [3625]	250 [3625]	250 [3625]	250 [3625]
Max. Starting Pressure with Unloaded Shaft, bar [PSI]		12 [174]	12 [174]	10 [145]	10 [145]	10 [145]	10 [145]
Min. Starting Torque, daNm [lb-in]	At max. press. drop Cont.	15 [1328]	19,2 [1699]	28,7 [2540]	36 [3186]	45,1 [3991]	52,8 [4673]
	At max. press. drop Int.*	17,6 [1558]	22,5 [1991]	31,5 [2788]	39,3 [3478]	49,2 [4355]	57,4 [5080]
Min. Speed***, [RPM]		12	12	10	10	10	10
Weight, kg [lb]	HW	14,1 [31.1]	14,2 [31.3]	14,3 [31.5]	14,6 [32.2]	15,1 [33.3]	15,5 [34.2]
	HWF	12,6 [27.8]	12,7 [28.0]	12,8 [28.2]	13,1 [28.9]	13,6 [30.0]	14,0 [30.9]
	HWFR	14,6 [32.2]	14,7 [32.4]	14,8 [32.6]	15,1 [33.3]	15,6 [34.4]	16,0 [35.3]
	HWFV	12,6 [27.8]	12,7 [28.0]	12,8 [28.2]	13,1 [28.9]	13,6 [30.0]	14,0 [30.9]
	HWS	13,8 [30.4]	13,9 [30.6]	14,0 [30.9]	14,3 [31.5]	14,8 [32.6]	15,2 [33.5]
	HWSW	13,5 [29.8]	13,6 [30.0]	13,7 [30.2]	14,0 [30.9]	14,5 [31.9]	14,9 [32.8]
	HWSR	15,8 [34.8]	15,9 [35.1]	16,0 [35.3]	16,3 [35.9]	16,8 [37.0]	17,2 [37.9]
	HWD	14,3 [31.5]	14,4 [31.8]	14,5 [31.9]	14,8 [32.6]	15,3 [33.7]	15,7 [34.6]
	HWV	13,8 [30.4]	13,9 [30.6]	14,0 [30.9]	14,3 [31.5]	14,8 [32.6]	15,2 [33.5]
	HWE	14,5 [31.9]	14,6 [32.2]	14,7 [32.4]	15,0 [33.1]	15,5 [34.2]	15,9 [35.1]
	HWSE	14,2 [31.3]	14,3 [31.5]	14,4 [31.8]	14,7 [32.4]	15,2 [33.5]	15,6 [34.4]
	HWFE	13,0 [28.7]	13,1 [28.9]	13,2 [29.1]	13,5 [29.8]	14,0 [30.9]	14,4 [31.8]
	HW(7,8,9,10)	16,0 [35.3]	16,1 [35.5]	16,2 [35.7]	16,5 [36.4]	17,0 [37.5]	17,4 [38.4]
	HWF(7,8,9,10)	14,5 [31.9]	14,6 [32.2]	14,7 [32.4]	15,0 [33.1]	15,5 [34.2]	15,9 [35.1]
HWS(7,8,9,10)	15,7 [34.6]	15,8 [34.8]	15,9 [35.1]	16,2 [35.7]	16,7 [36.8]	17,1 [37.7]	

* Intermittent operation: the permissible values may occur for max. 10% of every minute.

** For speeds lower than given, consult factory or your regional manager.

*** For "E"-option and versions 7,8,9,10 it is not recommendable a flow bigger than 75% of the nominal flow rate.

- Intermittent speed and intermittent pressure must not occur simultaneously.
- Recommended filtration is per ISO cleanliness code 20/16. A nominal filtration of 25 micron or better.
- Recommend using a premium quality, anti-wear type mineral based hydraulic oil HLP(DIN51524) or HM (ISO 6743/4).
If using synthetic fluids consult the factory for alternative seal materials.
- Recommended minimum oil viscosity 13 mm²/s [70 SUS] at 50°C [122°F].
- Recommended maximum system operating temperature is 82°C [180°F].
- To assure optimum motor life fill with fluid prior to loading and run at moderate load and speed for 10-15 minutes.

SPECIFICATION DATA

Type		HW 250	HW 300	HW 315	HW 350	HW 370	HW 400
Displacement, cm³/rev [in³/rev]		252 [15.38]	300 [18.31]	314,9 [19.22]	347,8 [21.22]	369,2 [22.53]	396,8 [24.21]
Max. Speed, [RPM]	Cont.	298	250	238	216	203	189
	Int.*	397	333	318	288	271	252
Max. Torque, daNm [lb-in]	Cont.	69 [6107]	81 [7170]	85 [7523]	94 [8320]	96 [8497]	96 [8497]
	Int.*	75 [6638]	89 [7877]	93 [8230]	102 [9028]	105 [9293]	98 [8674]
Max. Output, kW [HP]	Cont.	16,8 [22.5]	16,5 [22]	16,4 [21.9]	16,5 [22]	13,2 [17.7]	12,5 [16.8]
	Int.*	20,8 [27.9]	20,8 [27.9]	20,8 [27.9]	20,8 [27.9]	19,2 [25.7]	18,5 [24.8]
Max. Pressure Drop, bar [PSI]	Cont.	205 [2970]	205 [2970]	205 [2970]	205 [2970]	200 [2900]	185 [2680]
	Int.*	225 [3260]	225 [3260]	225 [3260]	225 [3260]	220 [3200]	190 [2760]
Max. Oil Flow, lpm [GPM]	Cont.	75 [20]	75 [20]	75 [20]	75 [20]	75 [20]	75 [20]
	Int.*	100 [26.4]	100 [26.4]	100 [26.4]	100 [26.4]	100 [26.4]	100 [26.4]
Max. Inlet Pressure, bar [PSI]	Cont.	210 [3050]	210 [3050]	210 [3050]	210 [3050]	210 [3050]	210 [3050]
	Int.*	250 [3625]	250 [3625]	250 [3625]	250 [3625]	250 [3625]	250 [3625]
Max. Starting Pressure with Unloaded Shaft, bar [PSI]		10 [145]	10 [145]	10 [145]	10 [145]	10 [145]	10 [145]
Min. Starting Torque, daNm [lb-in]	At max. press. drop Cont.	56,5 [5000]	66,4 [5877]	69,7 [6169]	77 [6815]	79,5 [7036]	78,7 [6966]
	At max. press. drop Int.*	61,5 [5443]	72,9 [6452]	76,2 [6744]	83,6 [7400]	86 [7612]	80,3 [7107]
Min. Speed***, [RPM]		10	10	10	8	8	8
Weight, kg [lb]	HW	15,7 [34.6]	16,1 [35.5]	16,3 [35.9]	16,7 [36.8]	16,9 [37.3]	17,3 [38.1]
	HWF	14,2 [31.3]	14,6 [32.2]	14,8 [32.6]	15,2 [33.5]	15,4 [34.0]	15,8 [34.8]
	HWFR	16,2 [35.7]	16,6 [36.6]	16,8 [37.0]	17,2 [37.9]	17,4 [38.4]	17,8 [39.2]
	HWFV	14,2 [31.3]	14,6 [32.2]	14,8 [32.6]	15,2 [33.5]	15,4 [34.0]	15,8 [34.8]
	HWS	15,4 [34.0]	15,8 [34.8]	16,0 [35.3]	16,4 [36.2]	16,6 [36.6]	17,0 [37.5]
	HWSW	15,1 [33.3]	15,5 [34.2]	15,7 [34.6]	16,1 [35.5]	16,3 [35.9]	16,7 [36.8]
	HWSR	17,4 [38.4]	17,8 [39.2]	18,0 [39.7]	18,4 [40.6]	18,6 [41.0]	19,0 [41.9]
	HWD	15,9 [35.1]	16,3 [35.9]	16,5 [36.4]	16,8 [37.0]	17,1 [37.7]	17,5 [38.6]
	HWV	15,4 [34.0]	15,8 [34.8]	16,0 [35.3]	16,4 [36.2]	16,6 [36.6]	17,0 [37.5]
	HWE	16,1 [35.5]	16,5 [36.4]	16,7 [36.8]	17,1 [37.7]	17,3 [38.1]	17,7 [39.0]
	HWSE	15,8 [34.8]	16,2 [35.7]	16,4 [36.2]	16,8 [37.0]	17,0 [37.5]	17,4 [38.4]
	HWFE	14,6 [32.2]	15,0 [33.1]	15,2 [33.5]	15,6 [34.4]	15,8 [34.8]	16,2 [35.7]
	HW(7,8,9,10)	17,6 [38.8]	18,0 [39.7]	18,2 [40.1]	18,6 [41.0]	18,8 [41.4]	19,2 [42.3]
	HWF(7,8,9,10)	16,1 [35.5]	16,5 [36.4]	16,7 [36.8]	17,1 [37.7]	17,3 [38.1]	17,7 [39.0]
HWS(7,8,9,10)	17,3 [38.1]	17,7 [39.0]	17,9 [39.5]	18,3 [40.3]	18,5 [40.8]	18,9 [41.7]	

* Intermittent operation: the permissible values may occur for max. 10% of every minute.

** For speeds lower than given, consult factory or your regional manager.

*** For "E"-option and versions 7,8,9,10 it is not recommendable a flow bigger than 75% of the nominal flow rate.

- Intermittent speed and intermittent pressure must not occur simultaneously.
- Recommended filtration is per ISO cleanliness code 20/16. A nominal filtration of 25 micron or better.
- Recommend using a premium quality, anti-wear type mineral based hydraulic oil HLP(DIN51524) or HM (ISO 6743/4).
If using synthetic fluids consult the factory for alternative seal materials.
- Recommended minimum oil viscosity 13 mm²/s [70 SUS] at 50°C [122°F].
- Recommended maximum system operating temperature is 82°C [180°F].
- To assure optimum motor life fill with fluid prior to loading and run at moderate load and speed for 10-15 minutes.

SPECIFICATION DATA

Type		HW 470	HW 500	HW 535	HW 550	HW 600	HW 750
Displacement, cm³/rev [in³/rev]		470,6 [28.72]	502,4 [30.66]	535 [32.65]	550 [33.56]	598,9 [36.55]	753,8 [45.99]
Max. Speed, [RPM]	Cont.	159	149	140	136	125	99
	Int.*	244	229	215	209	192	152
Max. Torque, daNm [lb-in]	Cont.	92 [8143]	91 [8054]	90 [7966]	89 [7877]	91 [8054]	92 [8143]
	Int.*	101 [8939]	101 [8939]	104 [9205]	105 [9293]	106 [9382]	106 [9382]
Max. Output, kW [HP]	Cont.	10,6 [14.2]	10,8 [14.5]	9,4 [12.6]	9 [12]	8,7 [11.7]	7,3 [9.8]
	Int.*	17,4 [23.3]	17,8 [23.9]	16,4 [22]	15,8 [21.2]	15,1 [20.2]	12,5 [16.8]
Max. Pressure Drop, bar [PSI]	Cont.	150 [2180]	140 [2030]	130 [1885]	125 [1815]	115 [1670]	95 [1380]
	Int.*	165 [2390]	155 [2250]	150 [2180]	145 [2105]	135 [1960]	105 [1520]
Max. Oil Flow, lpm [GPM]	Cont.	75 [20]	75 [20]	75 [20]	75 [20]	75 [20]	75 [20]
	Int.*	115 [30.4]	115 [30.4]	115 [30.4]	115 [30.4]	115 [30.4]	115 [30.4]
Max. Inlet Pressure, bar [PSI]	Cont.	210 [3050]	210 [3050]	210 [3050]	210 [3050]	210 [3050]	210 [3050]
	Int.*	250 [3625]	250 [3625]	250 [3625]	250 [3625]	250 [3625]	250 [3625]
Max. Starting Pressure with Unloaded Shaft, bar [PSI]		10 [145]	10 [145]	10 [145]	10 [145]	10 [145]	10 [145]
Min. Starting Torque, daNm [lb-in]	At max. press. drop Cont.	75,4 [6674]	74,6 [6603]	73,8 [6532]	72,9 [6452]	72,0 [6373]	73,6 [6515]
	At max. press. drop Int.*	82,8 [7328]	82,8 [7328]	85,2 [7540]	84,4 [7470]	83,8 [7417]	84,8 [7505]
Min. Speed***, [RPM]		8	8	5	5	5	4
Weight, kg [lb]	HW	18,1 [39.9]	18,4 [40.6]	18,8 [41.5]	18,9 [41.7]	20,4 [44.9]	21,9 [48.3]
	HWF	16,6 [36.6]	16,9 [37.3]	17,3 [38.1]	17,4 [38.4]	18,8 [41.4]	20,3 [44.6]
	HWFR	18,6 [41.0]	18,9 [41.7]	19,3 [42.5]	19,4 [42.8]	21,0 [46.3]	22,5 [49.6]
	HWFV	16,6 [36.6]	16,9 [37.3]	17,3 [38.1]	17,4 [38.4]	18,8 [41.4]	20,3 [44.6]
	HWS	17,8 [39.2]	18,1 [39.9]	18,5 [40.8]	18,6 [41.0]	20,1 [44.3]	21,6 [47.6]
	HWSW	17,5 [38.6]	17,8 [39.2]	18,2 [40.1]	18,3 [40.3]	19,8 [43.7]	21,3 [46.9]
	HWSR	19,8 [43.7]	20,1 [44.3]	20,5 [45.2]	20,6 [45.4]	22,2 [48.9]	23,7 [52.2]
	HWD	18,3 [40.3]	18,6 [41.0]	19,0 [41.9]	19,1 [42.1]	20,6 [45.4]	22,1 [48.7]
	HWV	17,8 [39.2]	18,1 [39.9]	18,5 [40.8]	18,6 [41.0]	20,1 [44.3]	21,6 [47.6]
	HWE	18,5 [40.8]	18,9 [41.7]	19,2 [42.3]	19,3 [42.5]	20,8 [45.9]	22,3 [49.2]
	HWSE	18,2 [40.1]	18,5 [40.8]	18,9 [41.7]	19,0 [41.9]	20,5 [45.2]	22,0 [48.5]
	HWFE	17,0 [37.5]	17,3 [38.1]	17,7 [39.0]	17,8 [39.2]	19,2 [42.3]	20,7 [45.6]
	HW(7,8,9,10)	20,0 [44.1]	20,3 [44.6]	20,7 [45.6]	20,8 [45.9]	22,3 [49.2]	23,8 [52.5]
	HWF(7,8,9,10)	18,5 [40.8]	18,8 [41.4]	19,2 [42.3]	19,3 [42.5]	20,7 [45.6]	22,2 [48.9]
HWS(7,8,9,10)	19,7 [43.4]	20,0 [44.1]	20,4 [44.9]	20,5 [45.2]	22,0 [48.5]	23,5 [51.8]	

* Intermittent operation: the permissible values may occur for max. 10% of every minute.

** For speeds lower than given, consult factory or your regional manager.

*** For "E"-option and versions 7,8,9,10 it is not recommendable a flow bigger than 75% of the nominal flow rate.

- Intermittent speed and intermittent pressure must not occur simultaneously.
- Recommended filtration is per ISO cleanliness code 20/16. A nominal filtration of 25 micron or better.
- Recommend using a premium quality, anti-wear type mineral based hydraulic oil HLP(DIN51524) or HM (ISO 6743/4).
If using synthetic fluids consult the factory for alternative seal materials.
- Recommended minimum oil viscosity 13 mm²/s [70 SUS] at 50°C [122°F].
- Recommended maximum system operating temperature is 82°C [180°F].
- To assure optimum motor life fill with fluid prior to loading and run at moderate load and speed for 10-15 minutes.

FUNCTION DIAGRAMS

HW 80

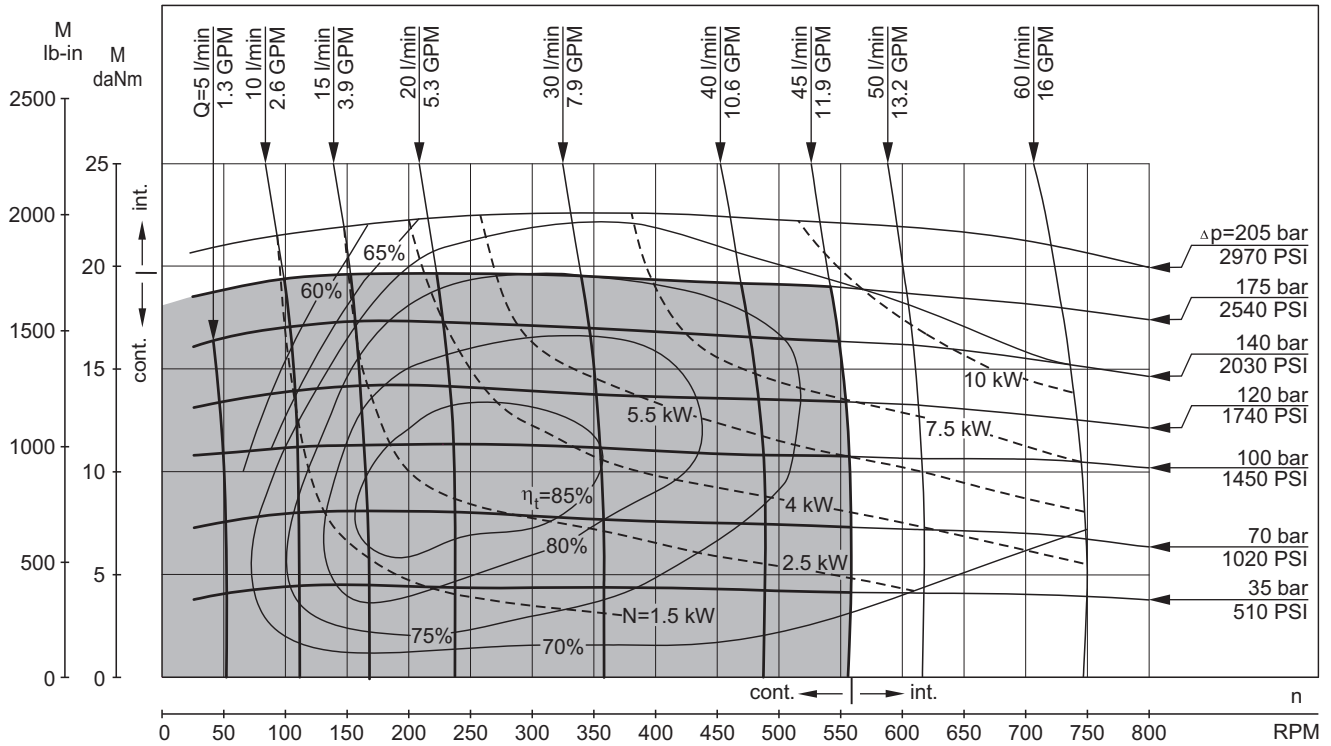

HW 100

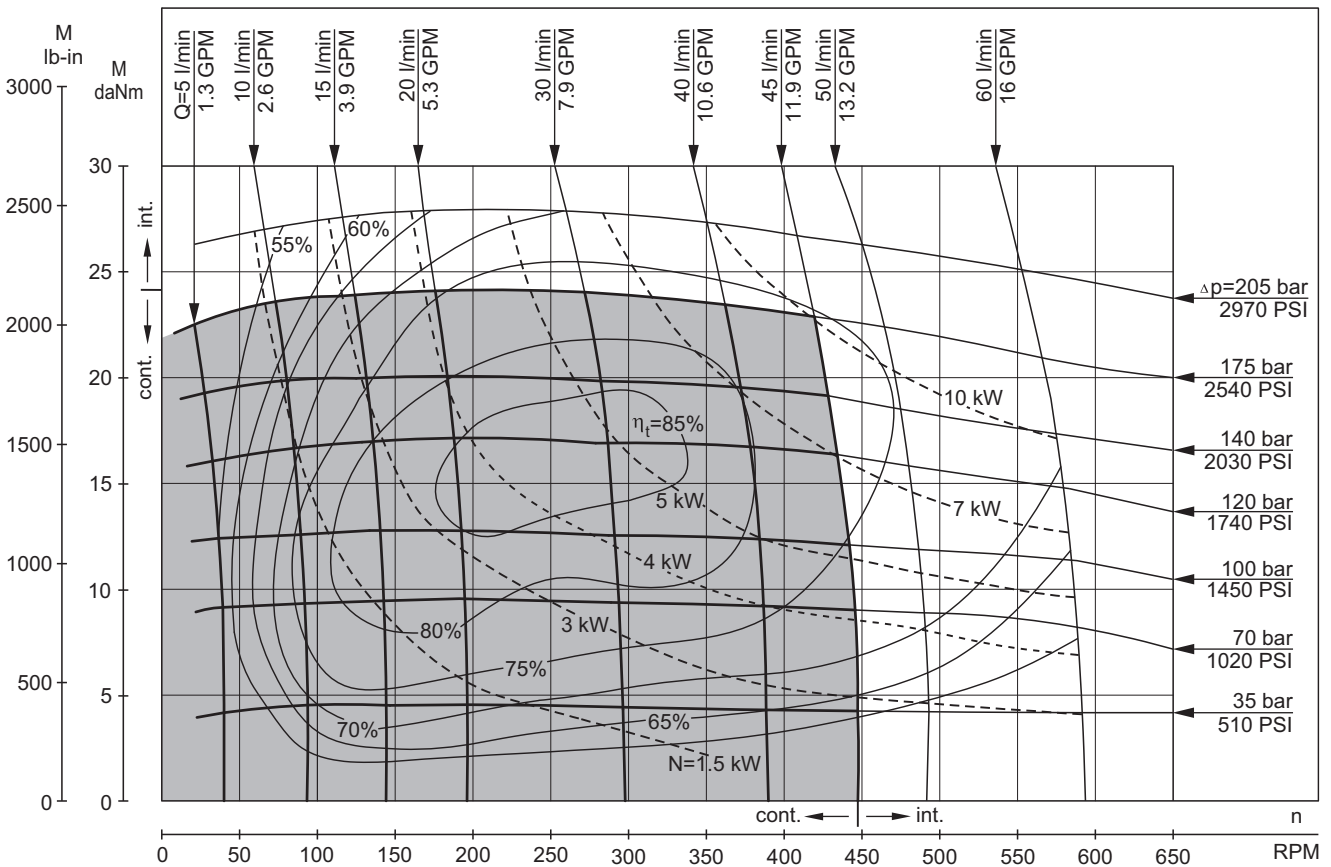

The function diagrams data is for average performance of randomly selected motors at back pressure 5±10 bar [72.5 PSI±145 PSI] and oil with viscosity of 32 mm²/s [150 SUS] at 50°C [122°F].

FUNCTION DIAGRAMS

HW 125

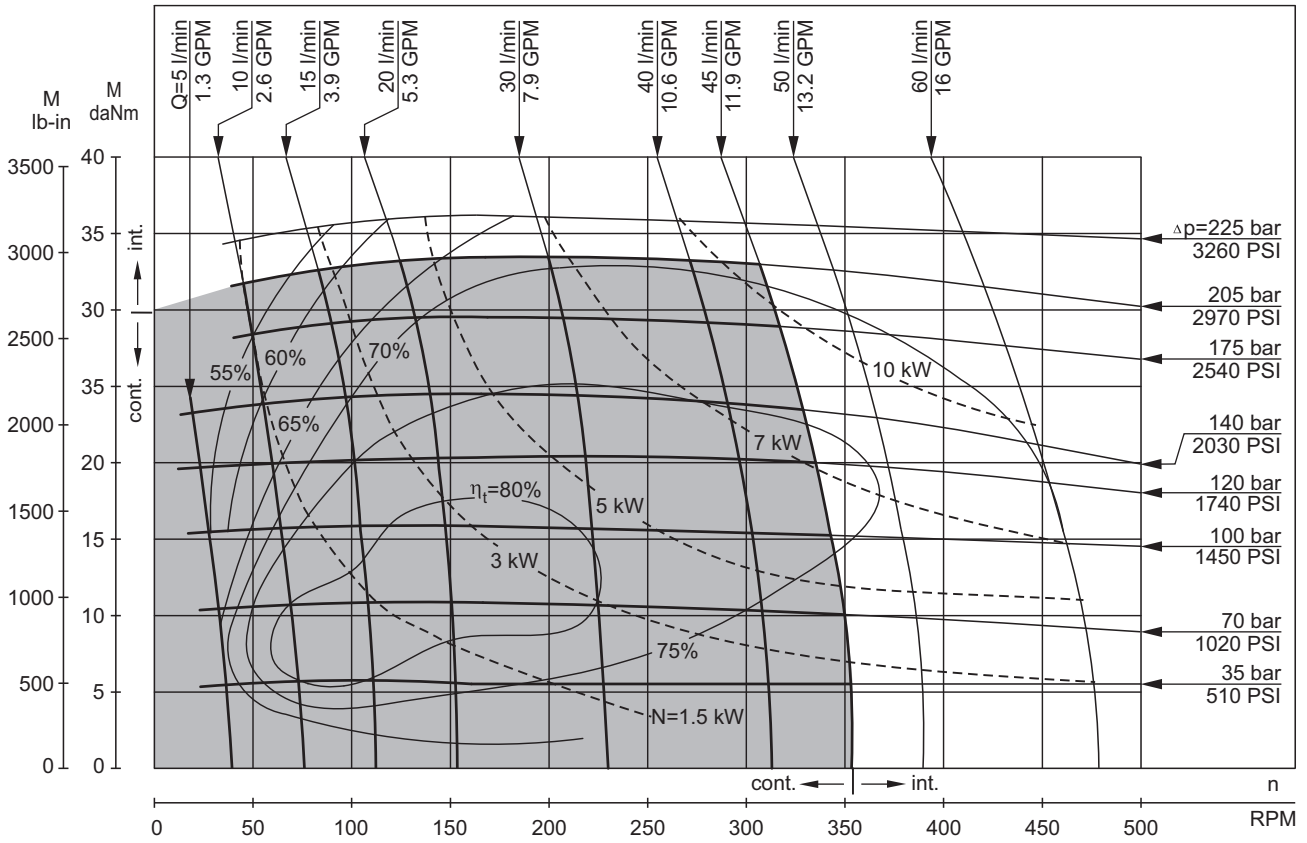

HW 160

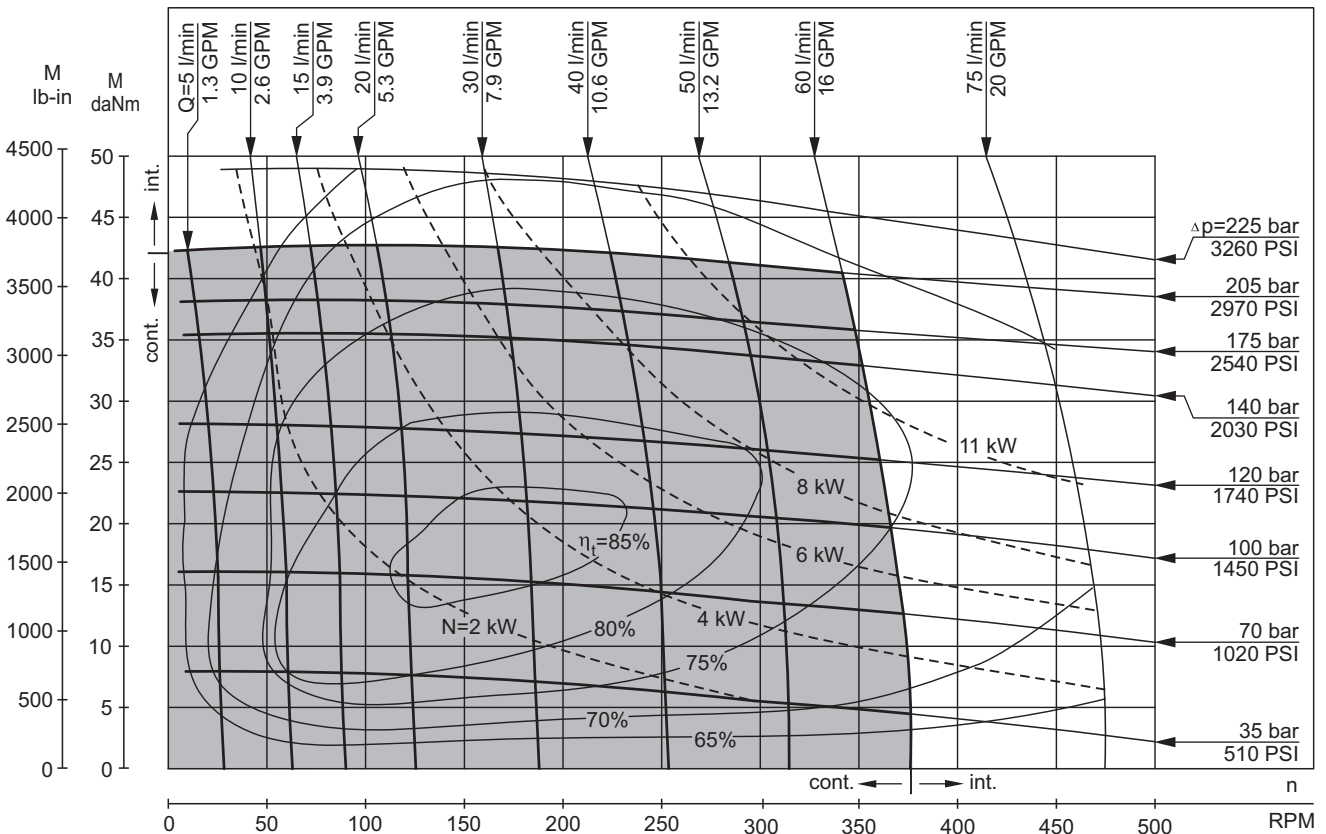

The function diagrams data is for average performance of randomly selected motors at back pressure 5÷10 bar [72.5 PSI÷145 PSI] and oil with viscosity of 32 mm²/s [150 SUS] at 50°C [122°F].

FUNCTION DIAGRAMS

HW 200

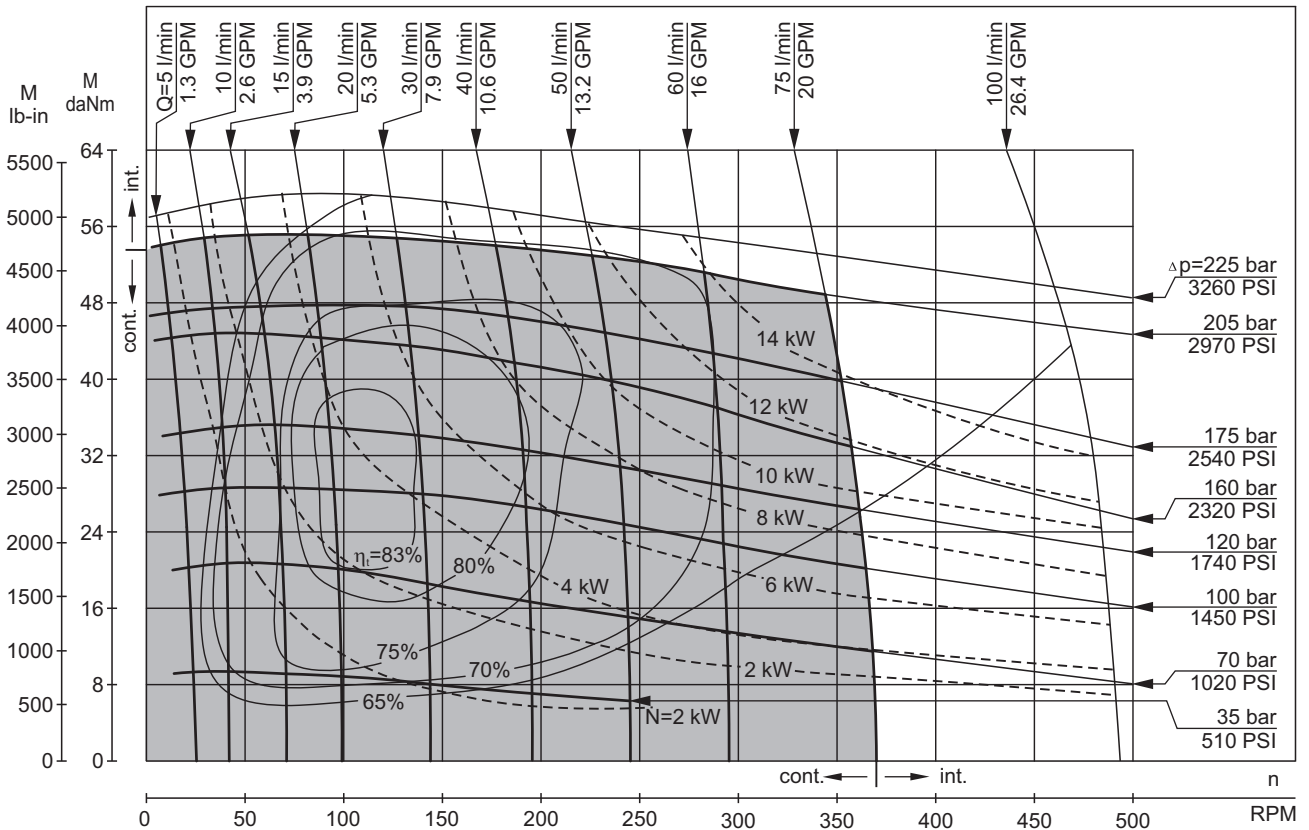

HW 235

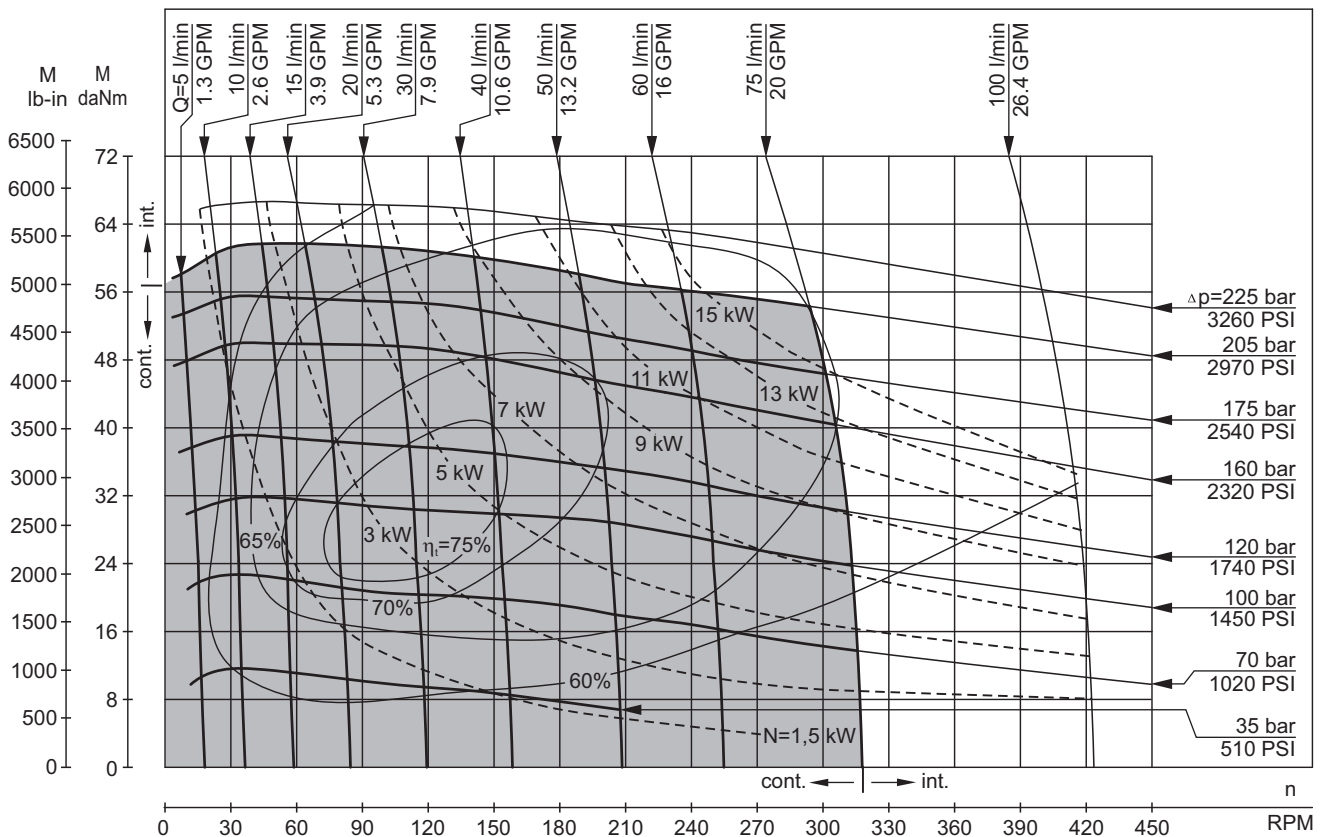

The function diagrams data is for average performance of randomly selected motors at back pressure 5±10 bar [72.5 PSI±145 PSI] and oil with viscosity of 32 mm²/s [150 SUS] at 50°C [122°F].

FUNCTION DIAGRAMS

HW 250

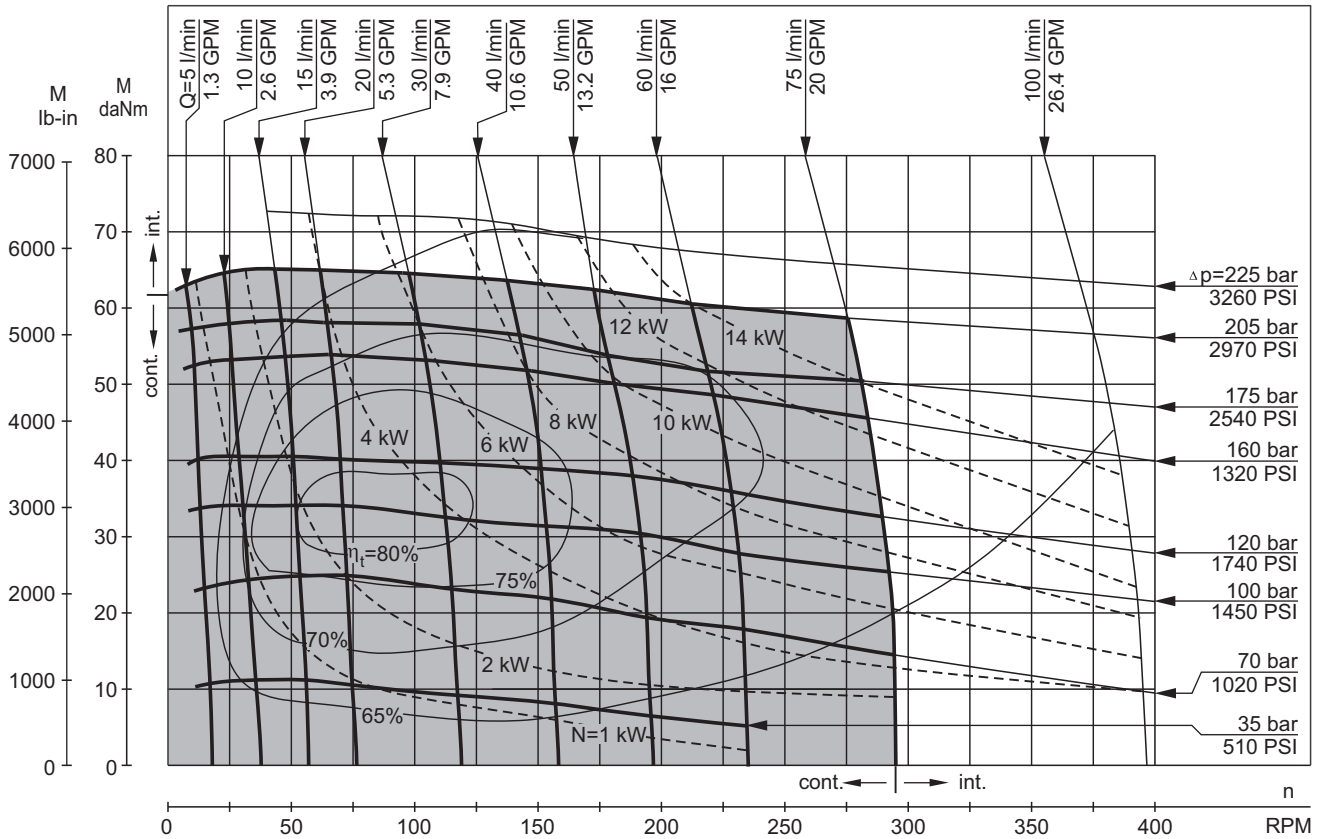

HW 300

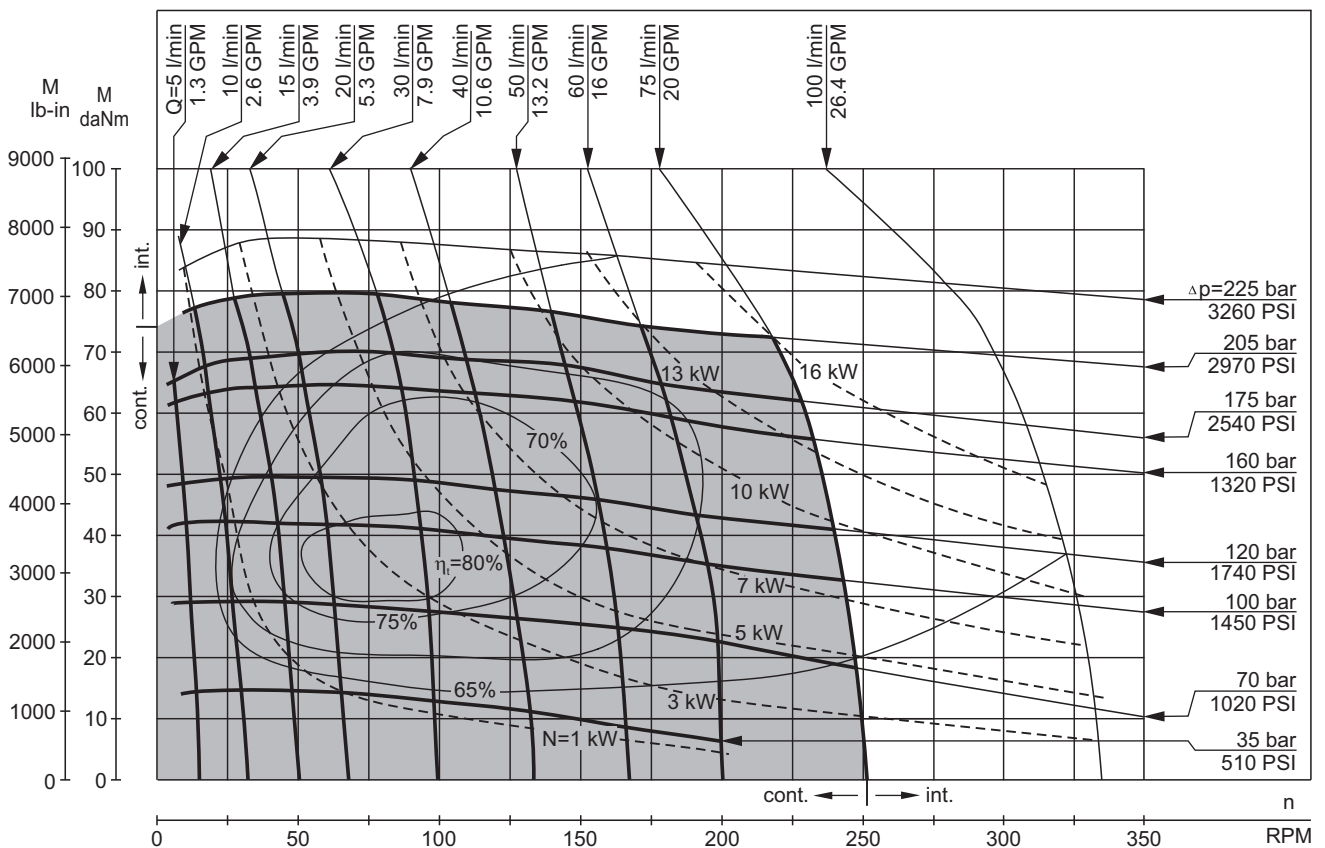

The function diagrams data is for average performance of randomly selected motors at back pressure 5÷10 bar [72.5 PSI÷145 PSI] and oil with viscosity of 32 mm²/s [150 SUS] at 50°C [122°F].

FUNCTION DIAGRAMS

HW 315

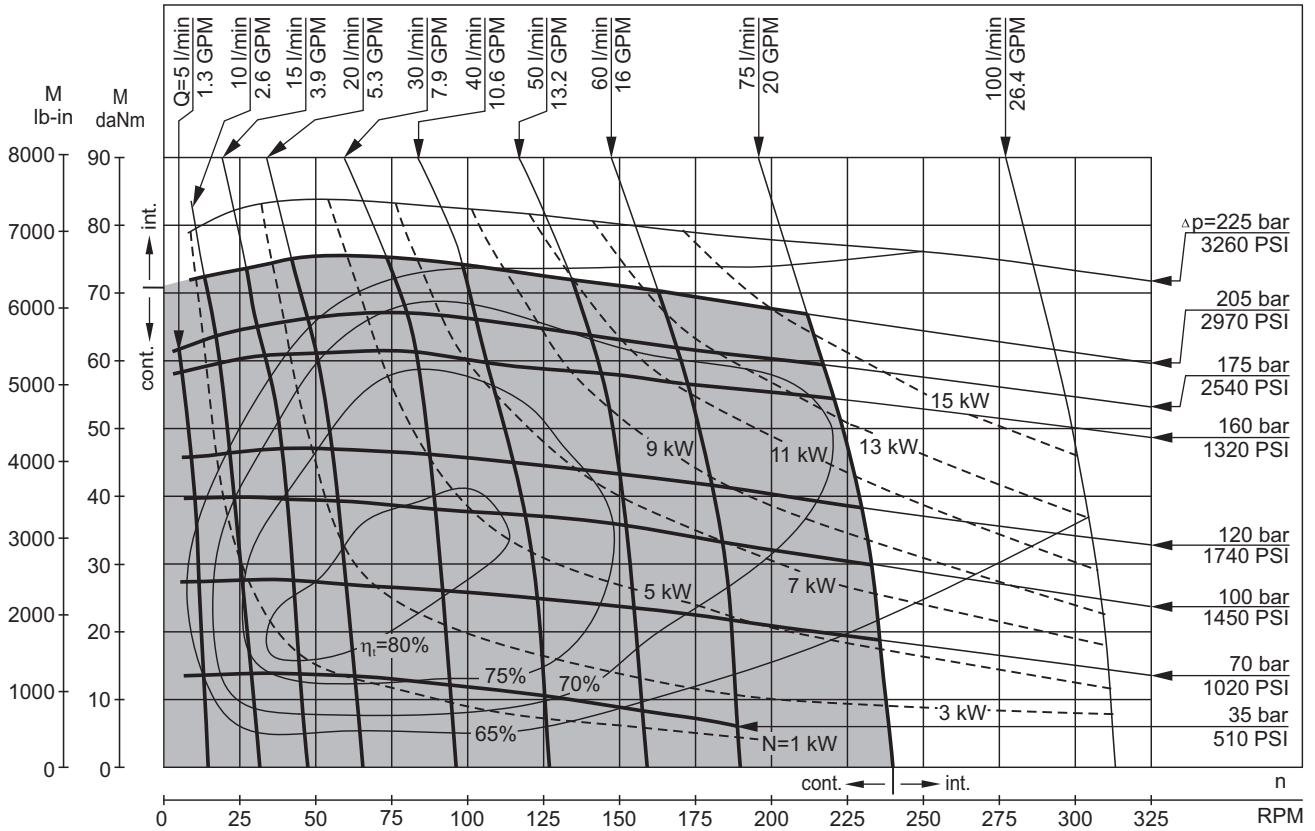

HW 350

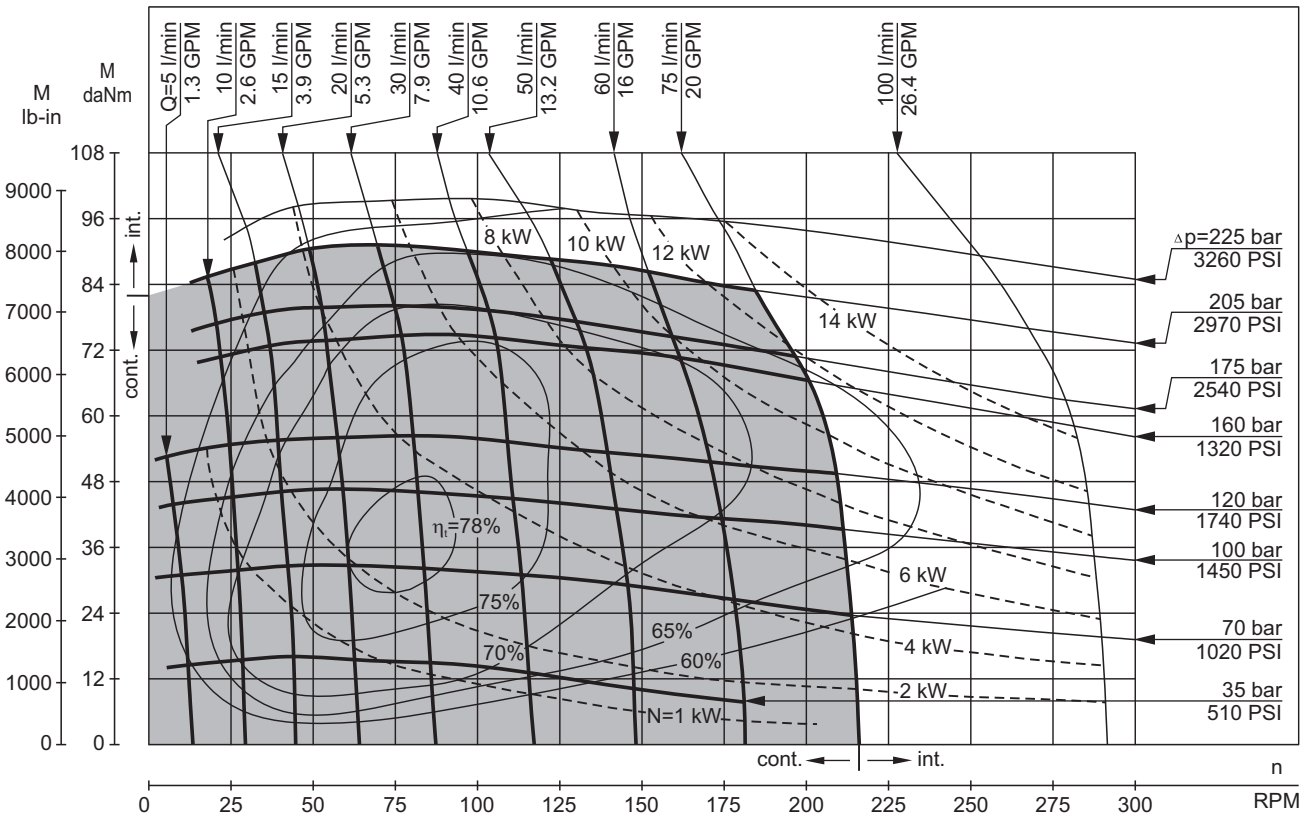

The function diagrams data is for average performance of randomly selected motors at back pressure 5±10 bar [72.5 PSI±145 PSI] and oil with viscosity of 32 mm²/s [150 SUS] at 50°C [122°F].

FUNCTION DIAGRAMS

HW 370

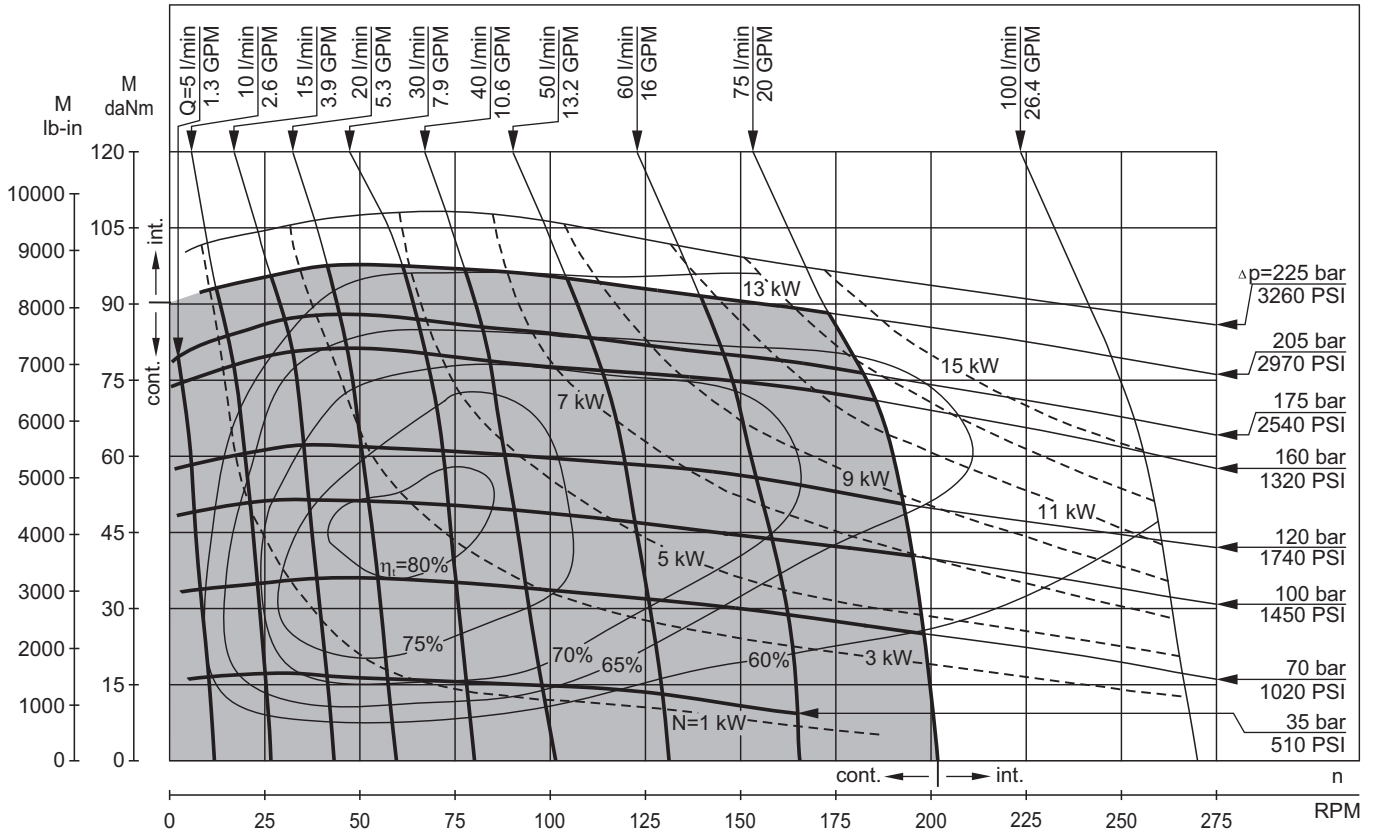

HW 400

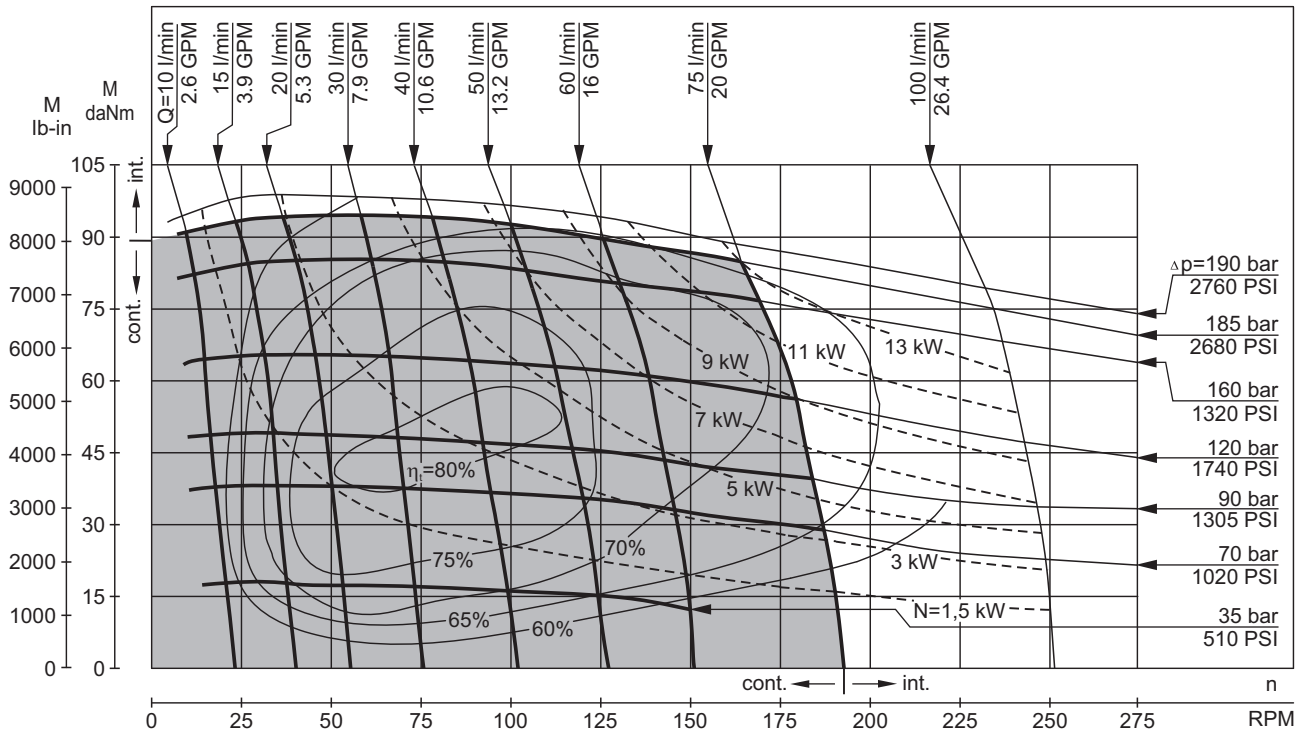

The function diagrams data is for average performance of randomly selected motors at back pressure 5÷10 bar [7.25 PSI÷145 PSI] and oil with viscosity of 32 mm²/s [150 SUS] at 50°C [122°F].

FUNCTION DIAGRAMS

HW 470

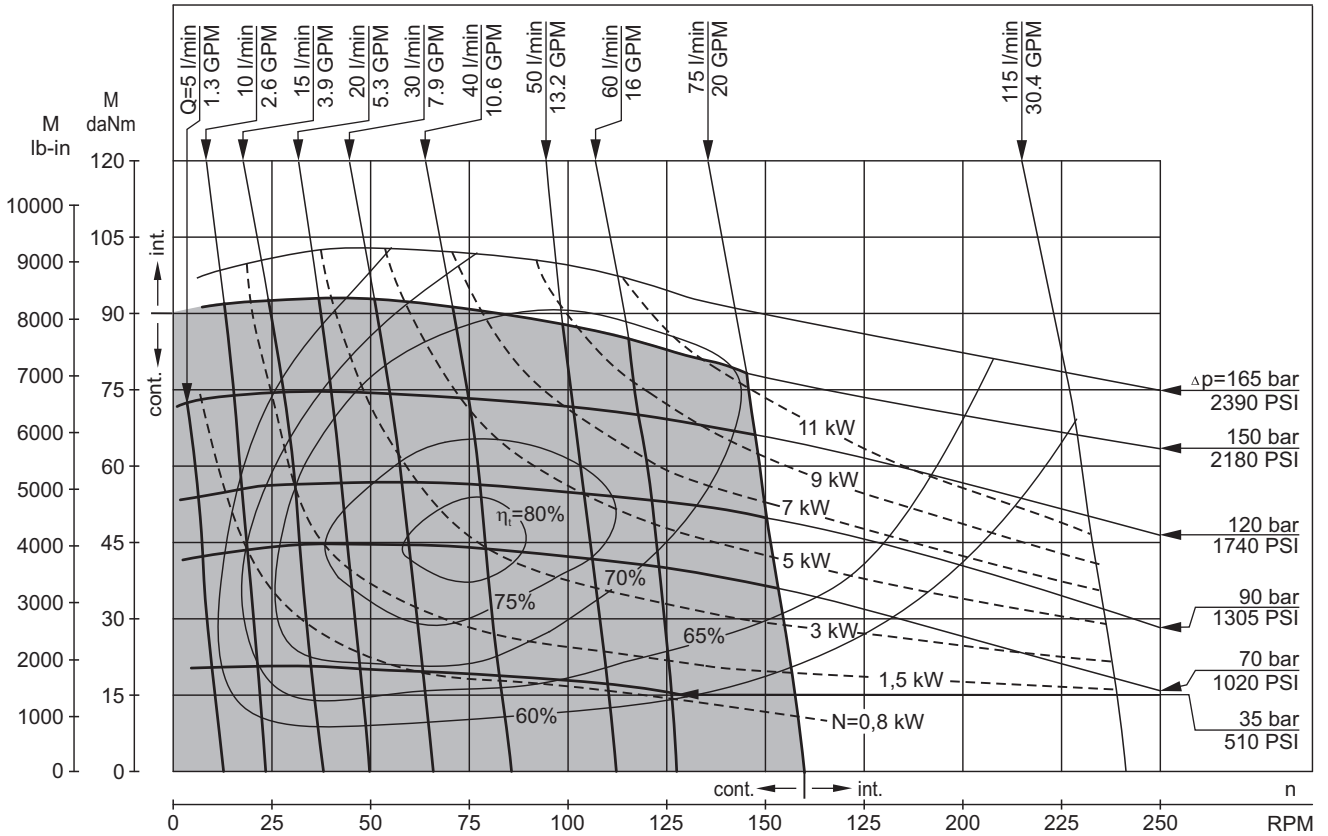

HW 500

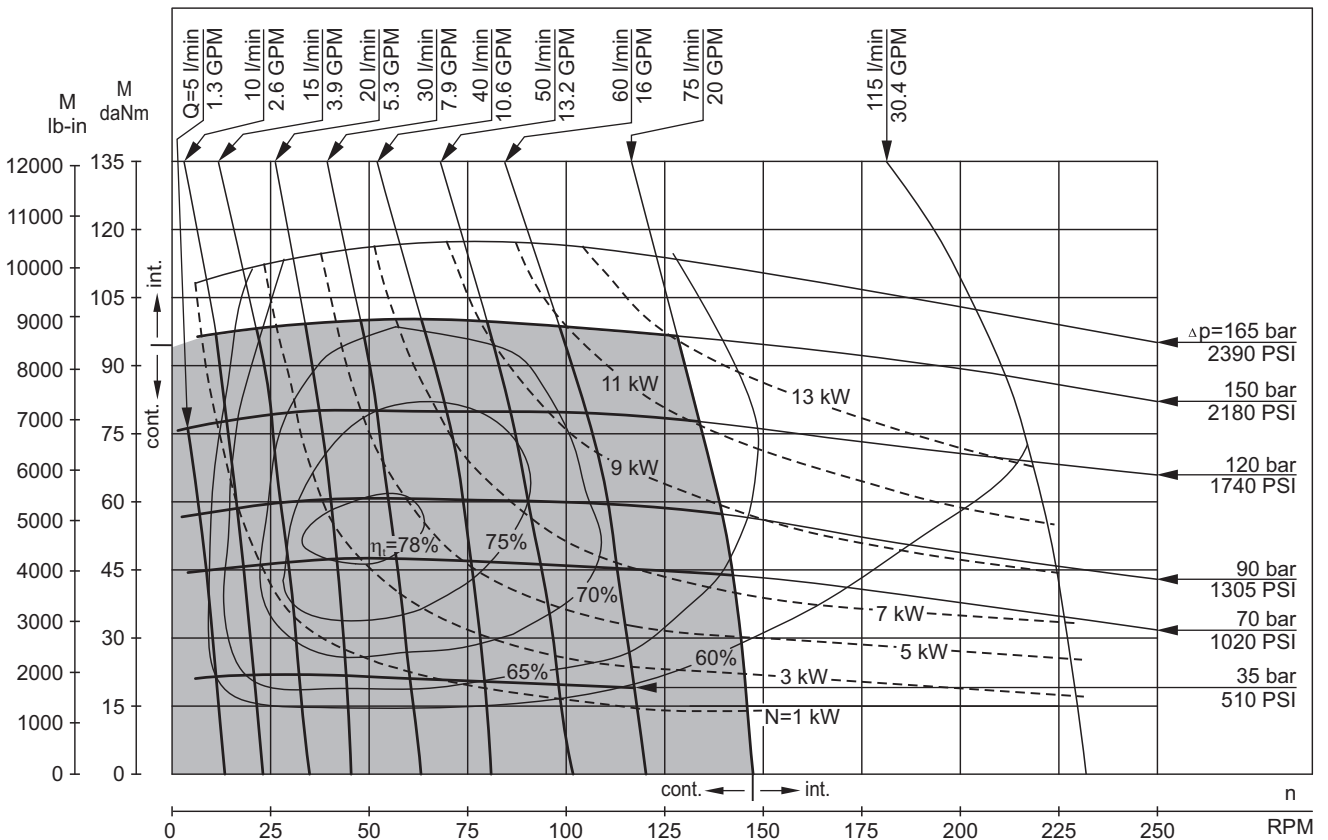

The function diagrams data is for average performance of randomly selected motors at back pressure 5÷10 bar [72.5 PSI÷145 PSI] and oil with viscosity of 32 mm²/s [150 SUS] at 50°C [122°F].

FUNCTION DIAGRAMS

HW 535

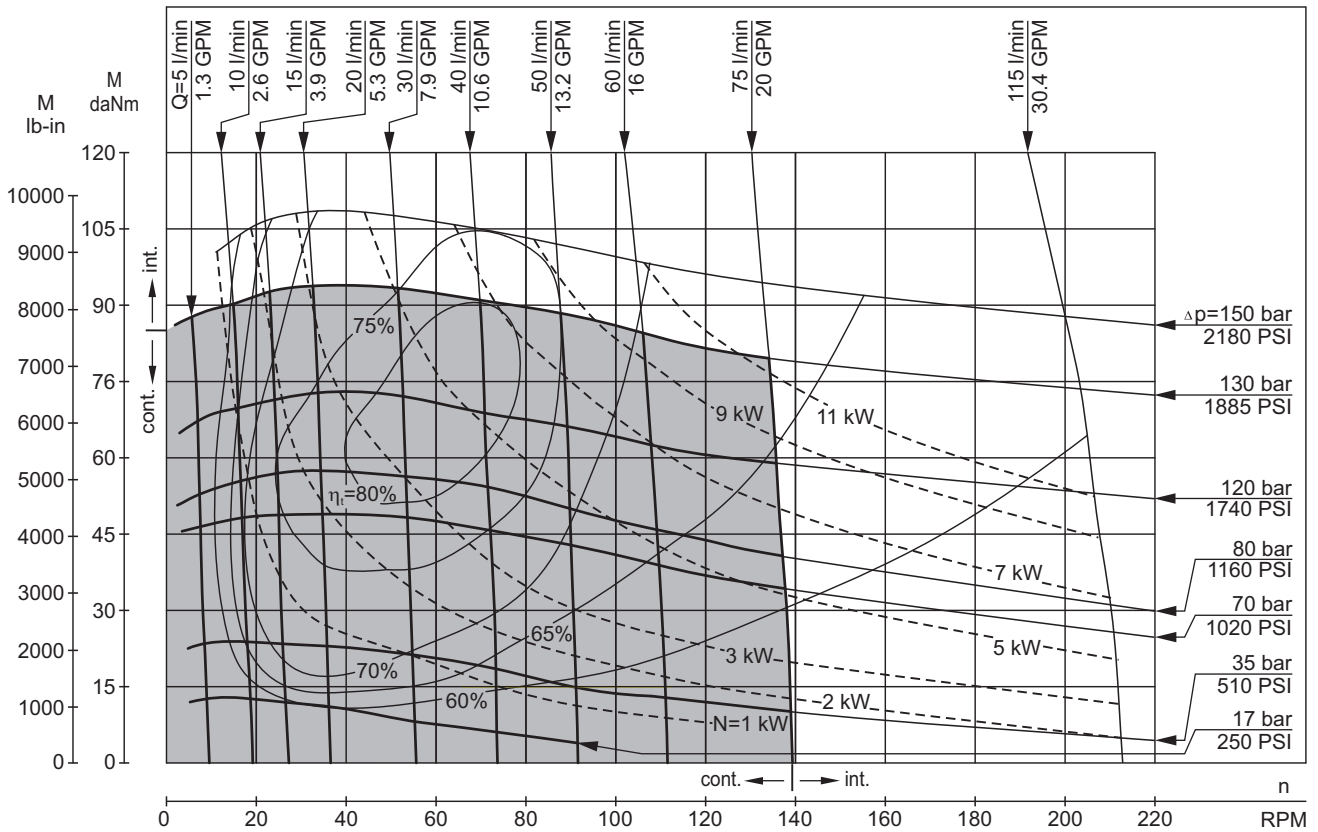

HW 550

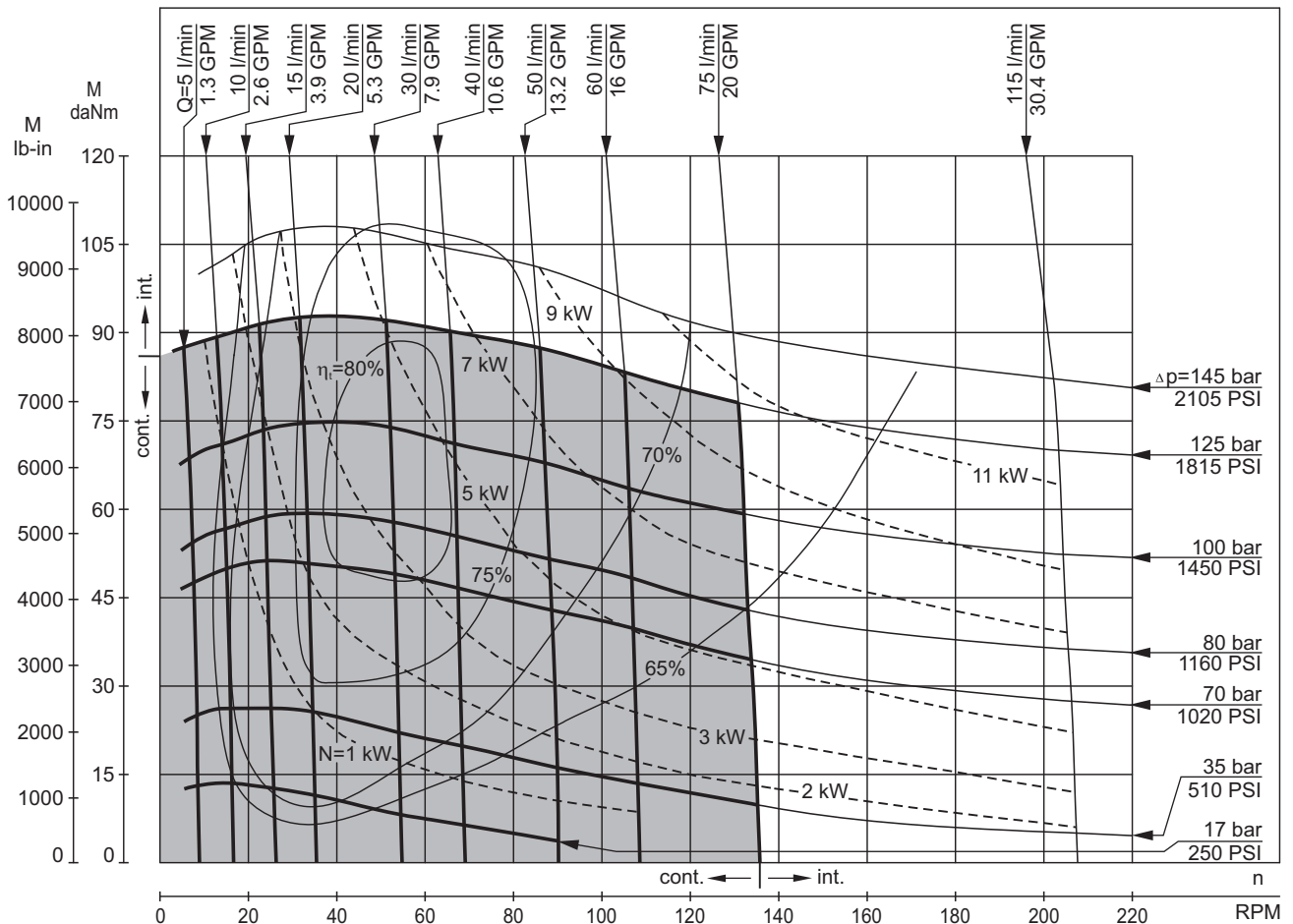

The function diagrams data is for average performance of randomly selected motors at back pressure 5±10 bar [72.5 PSI±145 PSI] and oil with viscosity of 32 mm²/s [150 SUS] at 50°C [122°F].

FUNCTION DIAGRAMS

HW 600

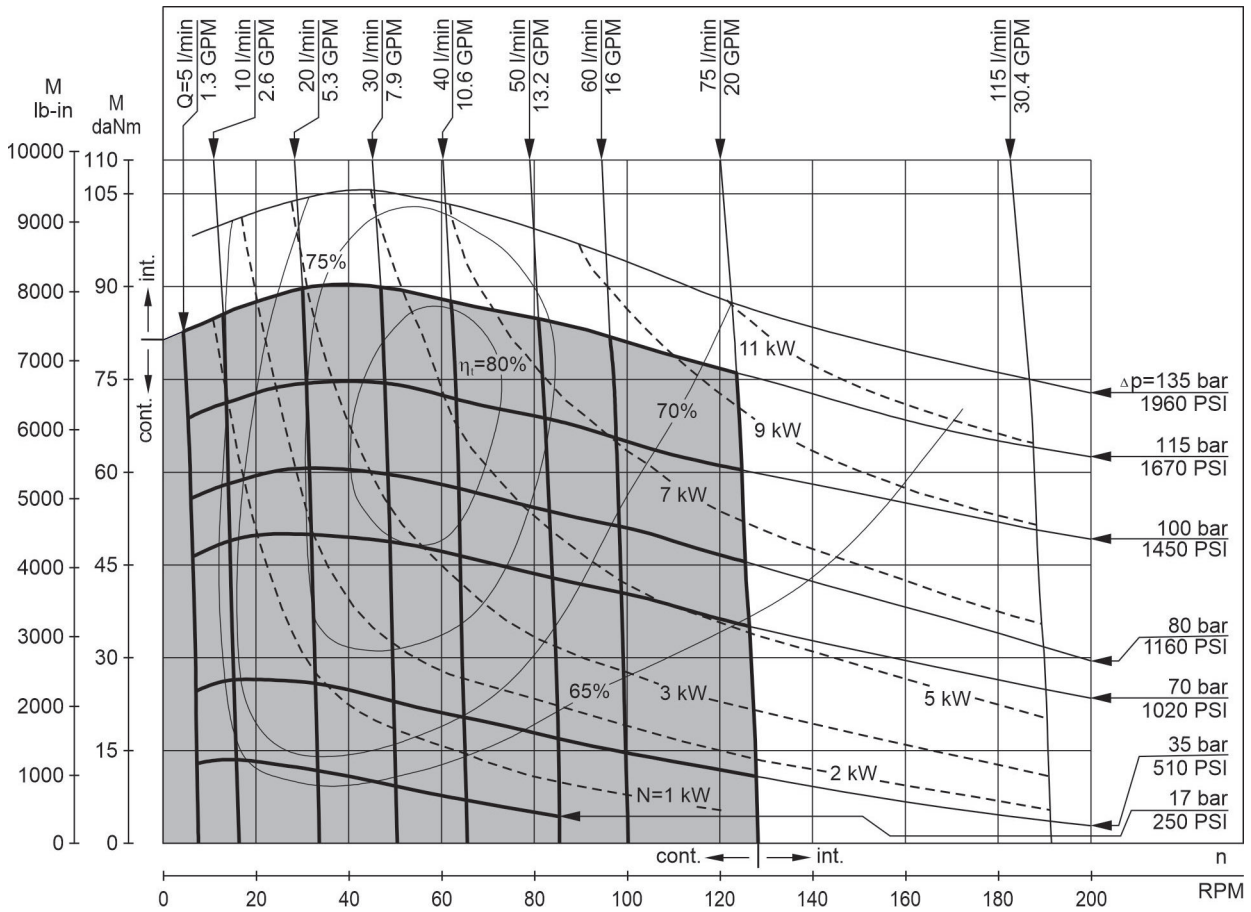

HW 750

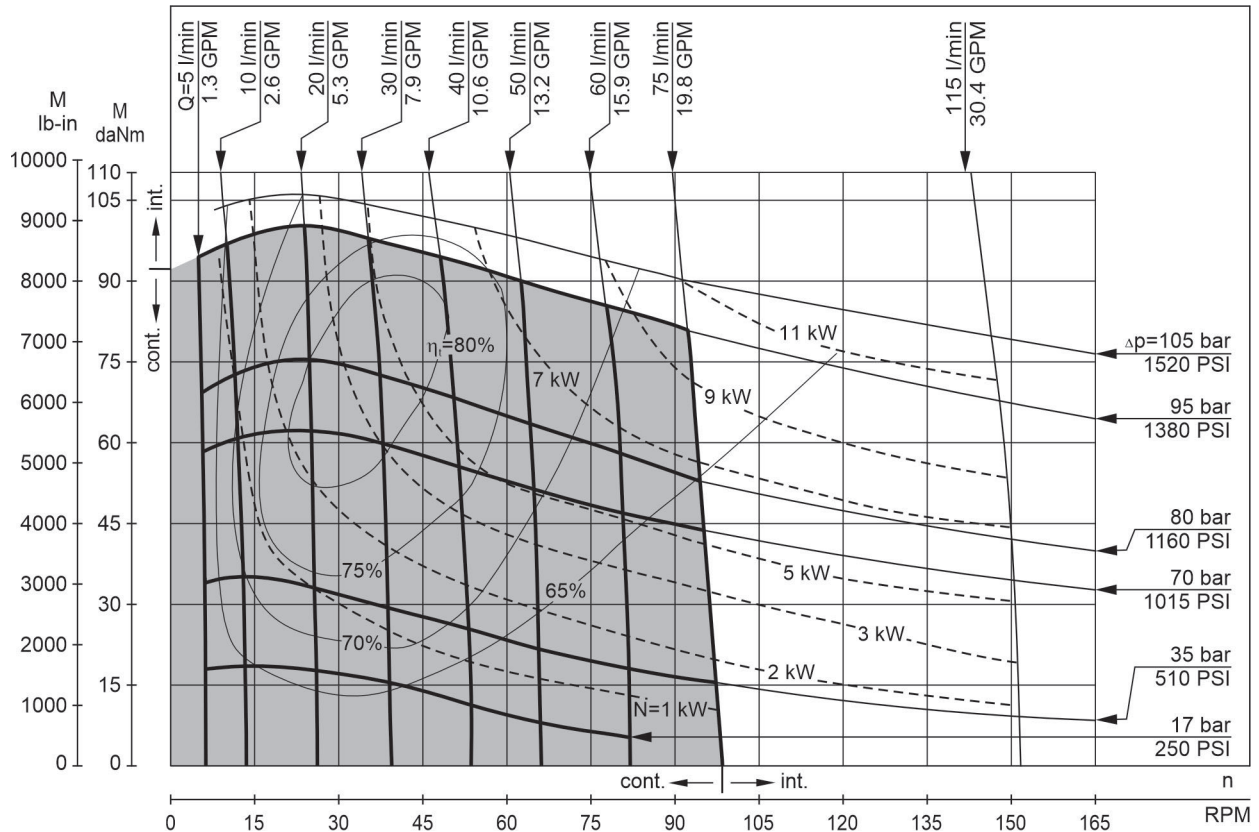

The function diagrams data is for average performance of randomly selected motors at back pressure 5±10 bar [72.5 PSI±145 PSI] and oil with viscosity of 32 mm²/s [150 SUS] at 50°C [122°F].

DIMENSIONS and MOUNTING DATA

HW Wheel mount

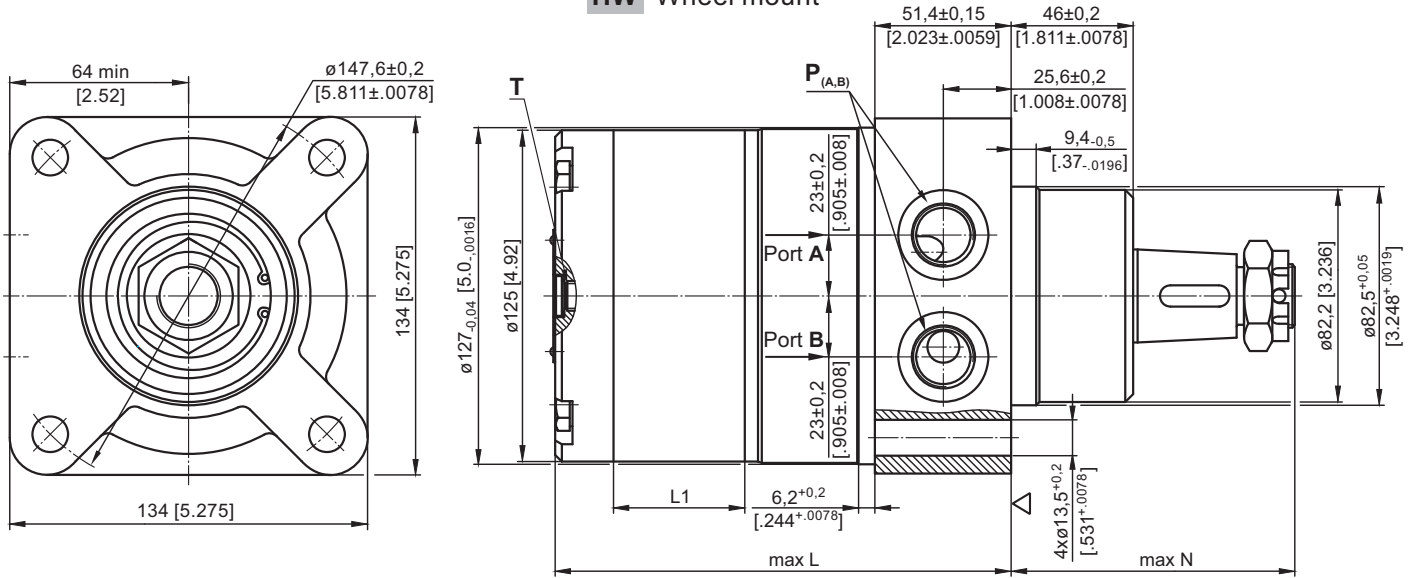

HWS Wheel mount

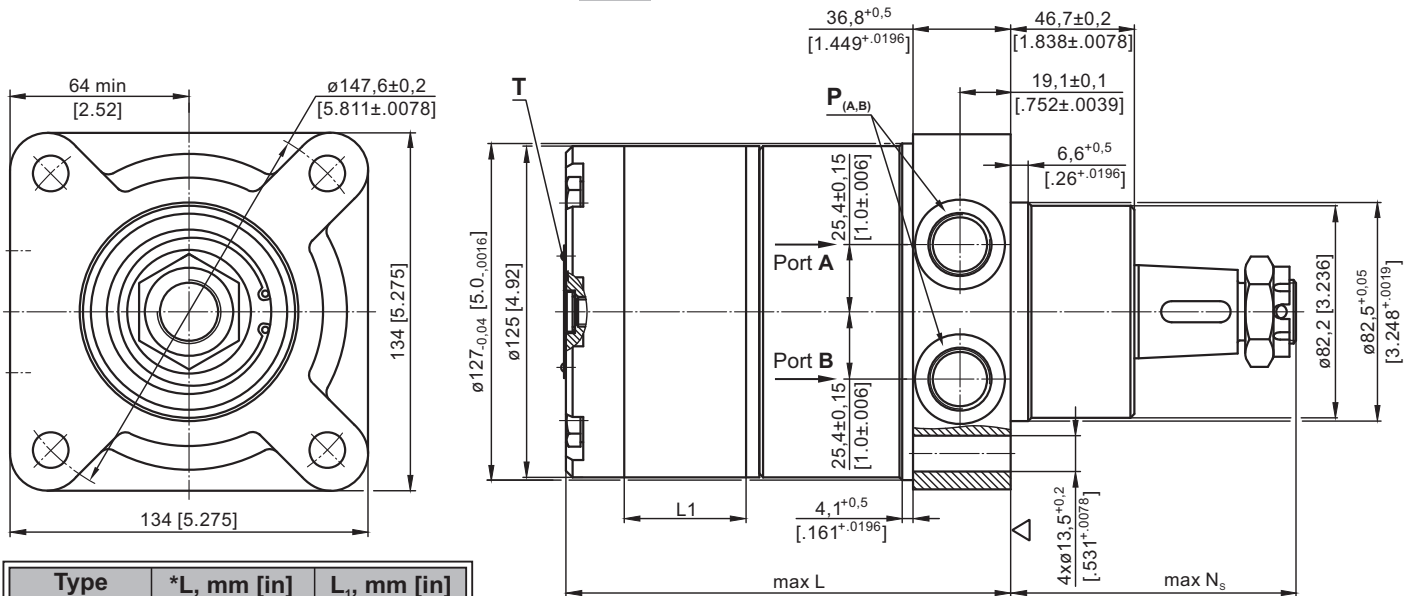

Type	*L, mm [in]	L _s , mm [in]
HW(S) 80	134,0 [5.28]	11,0 [.43]
HW(S) 100	137,0 [5.39]	14,0 [.55]
HW(S) 125	140,5 [5.51]	17,4 [.68]
HW(S) 160	145,0 [5.71]	21,8 [.86]
HW(S) 200	151,0 [5.95]	27,8 [1.09]
HW(S) 235	155,5 [6.12]	32,5 [1.28]
HW(S) 250	158,0 [6.22]	34,8 [1.37]
HW(S) 300	164,5 [6.48]	41,4 [1.63]
HW(S) 315	166,5 [6.56]	43,5 [1.71]
HW(S) 350	171,0 [6.73]	48,0 [1.89]
HW(S) 370	174,0 [6.85]	51,0 [2.01]
HW(S) 400	178,0 [7.01]	54,8 [2.16]
HW(S) 470	188,0 [7.40]	65,0 [2.56]
HW(S) 500	192,5 [7.58]	69,4 [2.73]
HW(S) 535	197,0 [7.76]	74,1 [2.92]
HW(S) 550	199,0 [7.84]	76,0 [2.99]
HW(S) 600	206,0 [8.11]	82,6 [3.25]
HW(S) 750	227,5 [8.96]	104,0 [4.09]

* For LSV option
the dimension L is 3 mm [.118 in] greater.

▽ - Motor Mounting Surface

Note: For N see pages 120,121 and 122.

	Versions	
	2	4
P _(A,B)	2xG½	2x7/8-14UNF, O-ring
T	G¼	7/16-20UNF, O-ring

Standard Rotation

Viewed from Shaft End

Port A Pressurized - CW

Port B Pressurized - CCW

Reverse Rotation

Viewed from Shaft End

Port A Pressurized - CCW

Port B Pressurized - CW



mm [in]

DIMENSIONS and MOUNTING DATA

HWSE Wheel mount, rear ports

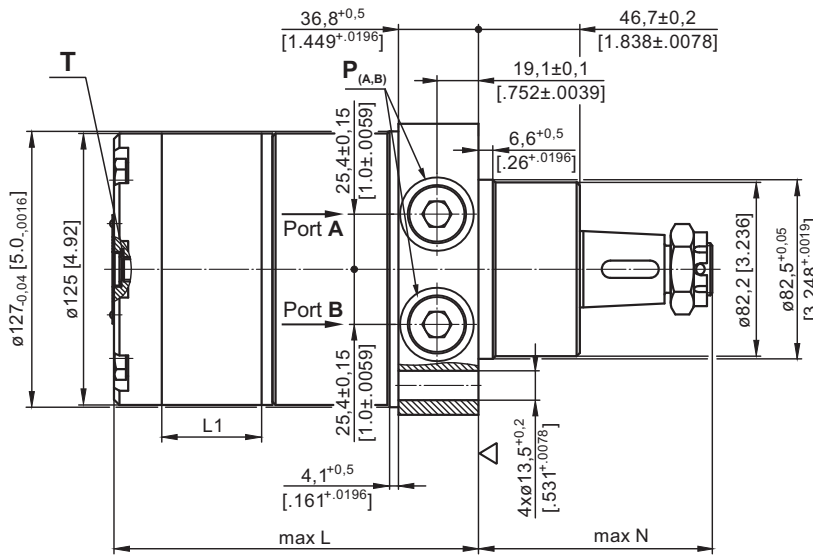

HWFE Magneto mount

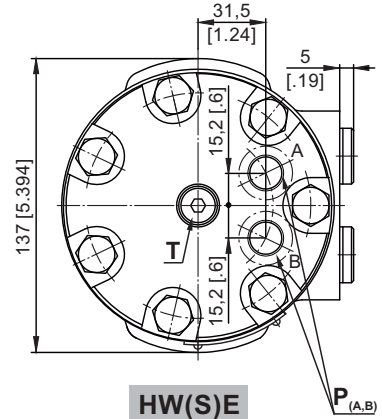

HWE Wheel mount, rear ports

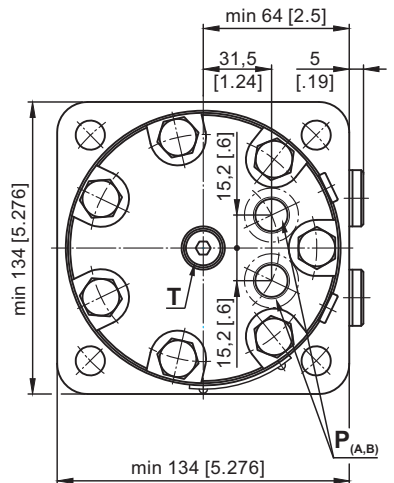
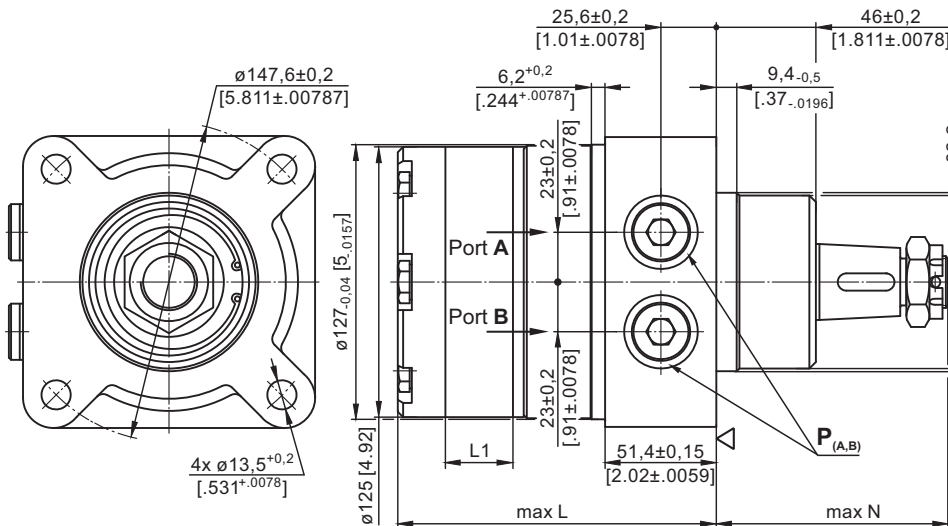

Type	*L, mm [in]		L ₁ , mm [in]
	HWE, HWSE	HWFE	
HW... 80	139,0 [5.47]	182,5 [7.19]	11,0 [4.3]
HW... 100	142,0 [5.59]	185,5 [7.30]	14,0 [5.5]
HW... 125	145,5 [5.73]	189,0 [7.44]	17,4 [6.8]
HW... 160	150,0 [5.91]	193,5 [7.62]	21,8 [8.6]
HW... 200	156,0 [6.14]	199,5 [7.85]	27,8 [1.09]
HW... 235	160,5 [6.32]	204,0 [8.03]	32,5 [1.28]
HW... 250	163,0 [6.42]	206,5 [8.13]	34,8 [1.37]
HW... 300	169,5 [6.67]	213,0 [8.39]	41,4 [1.63]
HW... 315	171,5 [6.75]	215,0 [8.46]	43,5 [1.71]
HW... 350	176,0 [6.93]	219,5 [8.64]	48,0 [1.89]
HW... 370	179,0 [7.05]	222,5 [8.76]	51,0 [2.01]
HW... 400	183,0 [7.20]	226,5 [8.92]	54,8 [2.16]
HW... 470	193,0 [7.60]	236,5 [9.31]	65,0 [2.56]
HW... 500	197,5 [7.78]	241,0 [9.49]	69,4 [2.73]
HW... 535	202,0 [7.95]	245,5 [9.67]	74,1 [2.92]
HW... 550	204,0 [8.03]	247,5 [9.74]	76,0 [2.99]
HW... 600	210,6 [8.29]	254,1 [10.00]	82,6 [3.25]
HW... 750	232,5 [9.15]	275,5 [10.85]	104,0 [4.09]

* For LSV option the dimension L is 3 mm [1.18 in] greater.

▽ - Motor mounting surface

Note: For N see pages 120, 121 and 122.

	Versions	
	5	6
P _(A,B)	2xG ³ / ₈	2x ⁹ / ₁₆ -18UNF, O-ring
T	G ¹ / ₄	⁷ / ₁₆ -20UNF, O-ring

Standard Rotation

Viewed from Shaft End
Port A Pressurized - CW
Port B Pressurized - CCW

Reverse Rotation

Viewed from Shaft End
Port A Pressurized - CCW
Port B Pressurized - CW



DIMENSIONS and MOUNTING DATA

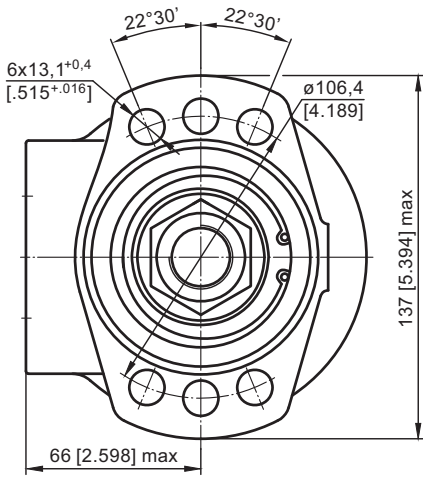

F Magneto mount, six holes

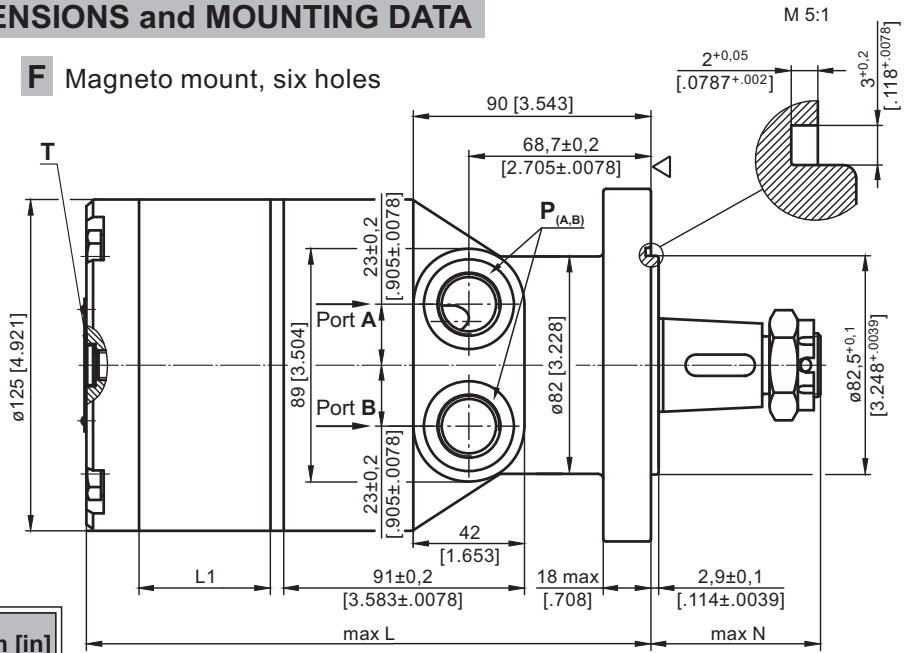

Type	*L, mm [in]		L ₁ , mm [in]
	HWSW	HWF(V)	
HW... 80	110,5 [4.35]	178,0 [7.01]	11,0 [4.43]
HW... 100	113,5 [4.47]	180,5 [7.11]	14,0 [5.5]
HW... 125	117,0 [4.61]	184,0 [7.24]	17,4 [6.8]
HW... 160	121,5 [4.78]	188,5 [7.42]	21,8 [8.6]
HW... 200	127,0 [5.00]	194,5 [7.66]	27,8 [1.09]
HW... 235	132,0 [5.20]	199,0 [7.84]	32,5 [1.28]
HW... 250	134,5 [5.30]	201,5 [7.93]	34,8 [1.37]
HW... 300	141,0 [5.55]	208,0 [8.20]	41,4 [1.63]
HW... 315	143,0 [5.63]	210,0 [8.27]	43,5 [1.71]
HW... 350	147,5 [5.81]	214,5 [8.45]	48,0 [1.89]
HW... 370	151,0 [5.94]	217,5 [8.56]	51,0 [2.01]
HW... 400	154,5 [6.08]	221,5 [8.72]	54,8 [2.16]
HW... 470	164,5 [6.48]	231,5 [9.11]	65,0 [2.56]
HW... 500	169,0 [6.65]	236,0 [9.29]	69,4 [2.73]
HW... 535	174,0 [6.85]	240,5 [9.47]	74,1 [2.92]
HW... 550	175,5 [6.91]	242,5 [9.55]	76,0 [2.99]
HW... 600	182,1 [7.16]	249,1 [9.81]	82,6 [3.25]
HW... 750	203,5 [8.01]	270,5 [10.65]	104,0 [4.09]

HWFV Magneto mount, six holes, relief valves

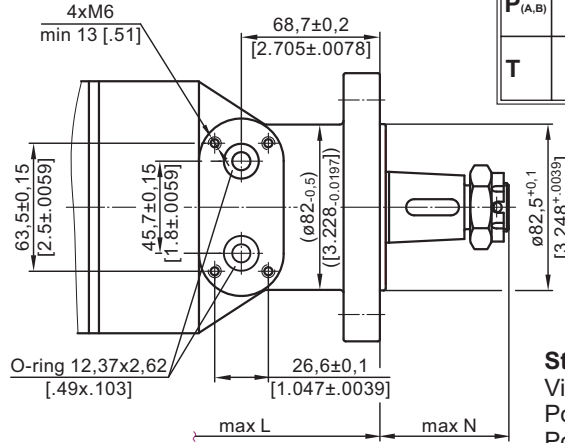

	Versions	
	2	4
P _(A,B)	2xG $\frac{1}{2}$	2x $\frac{7}{8}$ -14UNF, O-ring
T	G $\frac{1}{4}$	$\frac{7}{16}$ -20UNF, O-ring



Standard Rotation
Viewed from Shaft End
Port A Pressurized - CW
Port B Pressurized - CCW

Reverse Rotation
Viewed from Shaft End
Port A Pressurized - CCW
Port B Pressurized - CW

HWSW Wheel mount

* For LSV option the dimension L is 3 mm [0.118 in] greater.

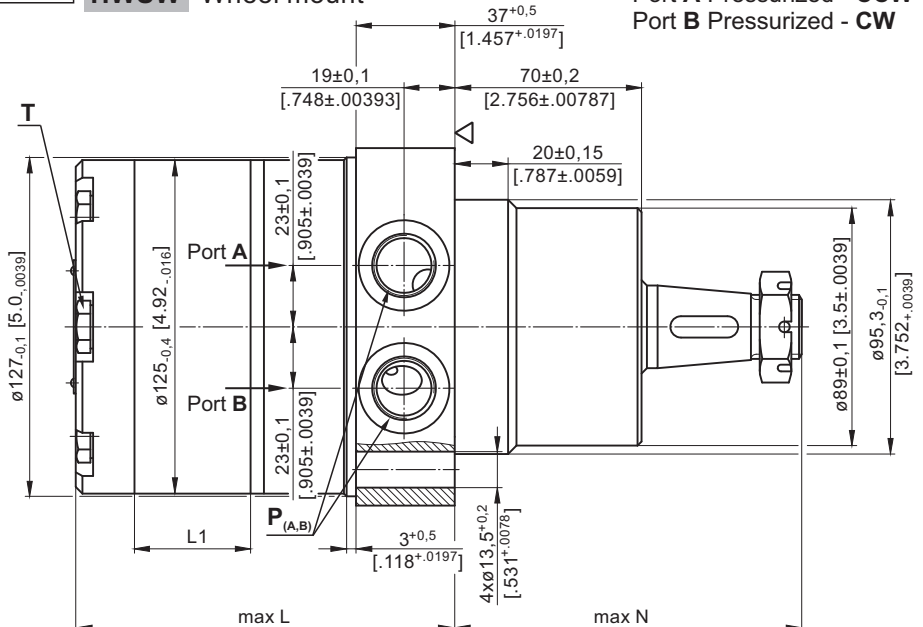
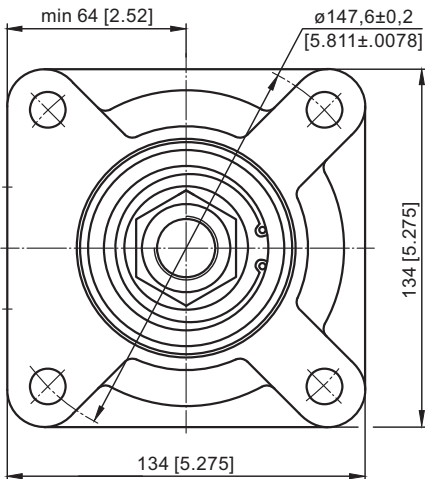

▽ - Motor mounting surface

Note: For N see pages 120,121 and 122.

DIMENSIONS and MOUNTING DATA

HWSWR Wheel mount, relief valves

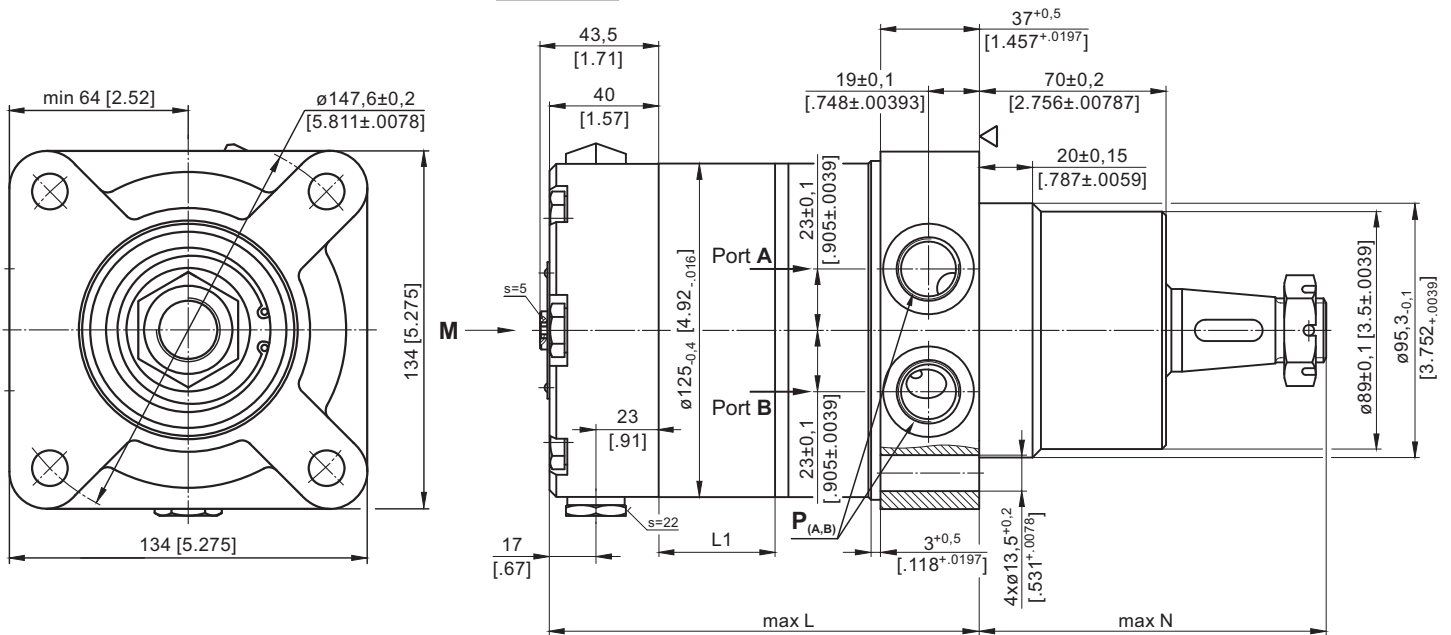

Note: For N see pages 120, 121 and 122.

Type	*L, mm [in]	L _v , mm [in]
HWSWR 80	128,5 [5.28]	11,0 [0.43]
HWSWR 100	131,5 [5.39]	14,0 [0.55]
HWSWR 125	135 [5.51]	17,4 [0.68]
HWSWR 160	139,5 [5.71]	21,8 [0.86]
HWSWR 200	145,0 [5.95]	27,8 [1.09]
HWSWR 235	150,0 [6.12]	32,5 [1.28]
HWSWR 250	152,5 [6.22]	34,8 [1.37]
HWSWR 300	159,0 [6.48]	41,4 [1.63]
HWSWR 315	161,0 [6.56]	43,5 [1.71]
HWSWR 350	165,5 [6.73]	48,0 [1.89]
HWSWR 370	169,0 [6.85]	51,0 [2.01]
HWSWR 400	172,5 [7.01]	54,8 [2.16]
HWSWR 470	182,5 [7.40]	65,0 [2.56]
HWSWR 500	187,0 [7.58]	69,4 [2.73]
HWSWR 535	192,0 [7.76]	74,1 [2.92]
HWSWR 550	193,5 [7.84]	76,0 [2.99]
HWSWR 600	200,0 [8.09]	82,6 [3.25]
HWSWR 750	221,0 [8.70]	104,0 [4.09]

* For LSV option the dimension L is 3 mm [0.118 in] greater.

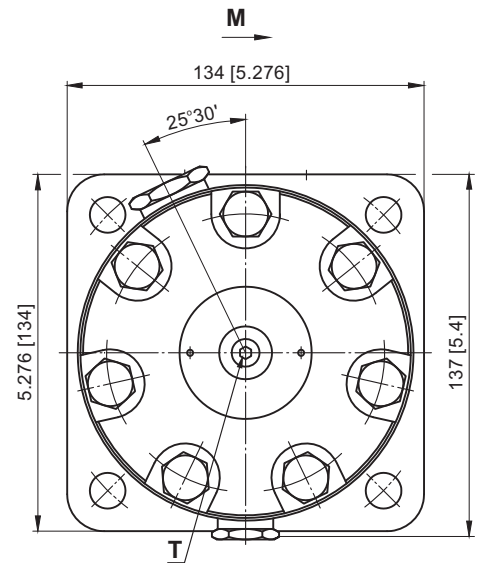

**Pressure Settings at Flow Q=5 lpm [1.32 GPM]
32 mm²/s [150 SUS]; 50°C [122°F]**

- 1 - 70 bar [1015 PSI]
- 2 - 100 bar [1450 PSI]
- 3 - 140 bar [2030 PSI]
- 4 - 170 bar [2470 PSI]
- 5 - 210 bar [3050 PSI]

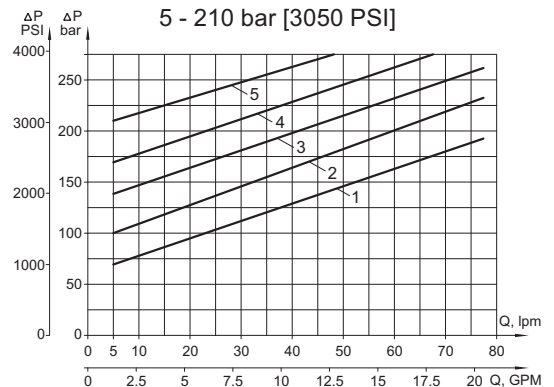

Standard Rotation
Viewed from Shaft End
Port A Pressurized - CW
Port B Pressurized - CCW

Reverse Rotation
Viewed from Shaft End
Port A Pressurized - CCW
Port B Pressurized - CW

DIMENSIONS and MOUNTING DATA

HWSR Wheel mount, relief valves

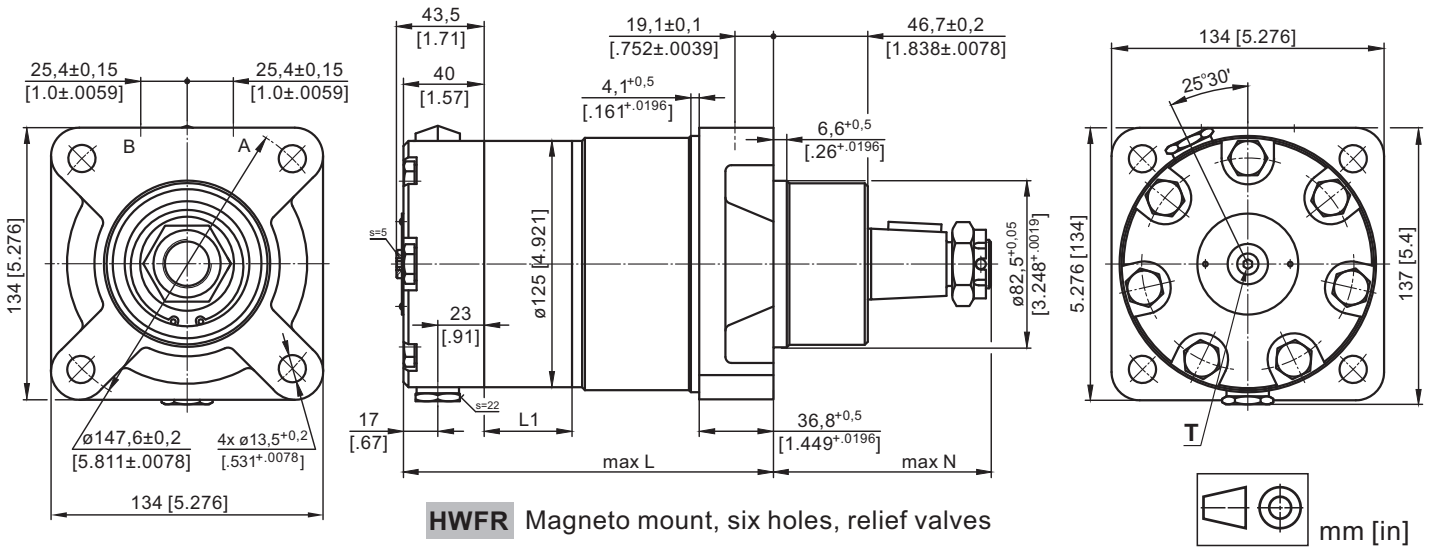

HWFR Magneto mount, six holes, relief valves

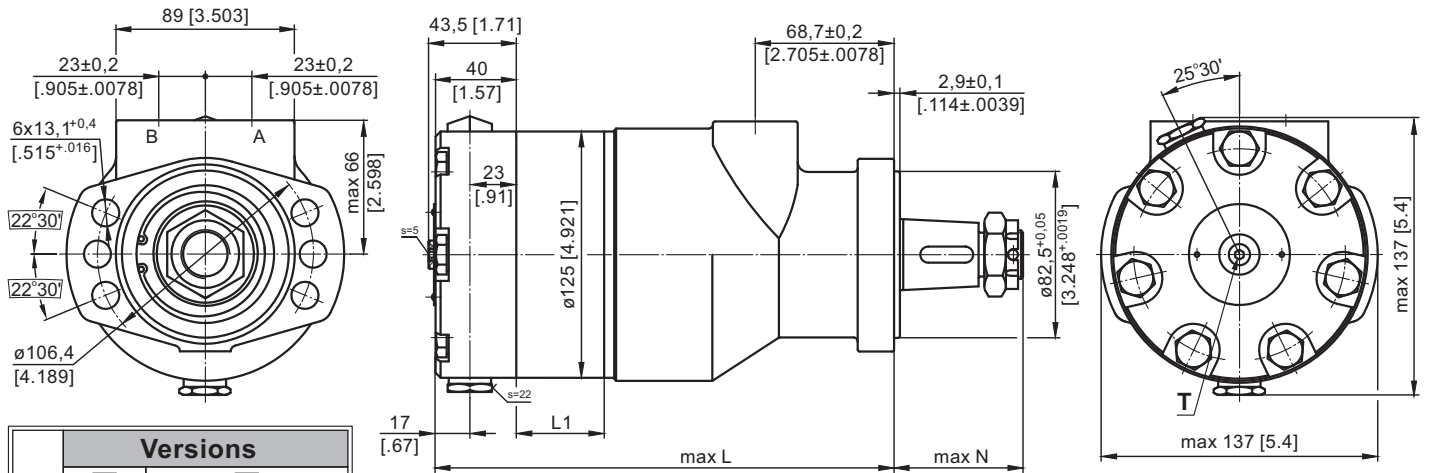

Versions	
2	4
P _(A,B) 2xG ¹ / ₂	2xG ⁷ / ₈ -14UNF, O-ring
T G ¹ / ₈	G ¹ / ₈

▽ - Motor mounting surface

Note: For N see pages 120,121 and 122.

Standard Rotation
Viewed from Shaft End
Port A Pressurized - CW
Port B Pressurized - CCW

Reverse Rotation
Viewed from Shaft End
Port A Pressurized - CCW
Port B Pressurized - CW

Type	80	*L, mm [in]		L ₁ , mm [in]
		HWSR	HWFR	
HW... 80	80	152,0 [5.98]	195,5 [7.69]	11,0 [.43]
HW... 100	100	155,0 [6.10]	198,5 [7.81]	14,0 [.55]
HW... 125	125	158,5 [6.24]	202,0 [7.95]	17,4 [.68]
HW... 160	160	163,0 [6.42]	206,5 [8.13]	21,8 [.86]
HW... 200	200	169,0 [6.65]	212,5 [8.37]	27,8 [1.09]
HW... 235	235	173,5 [6.83]	217,0 [8.54]	32,5 [1.28]
HW... 250	250	176,0 [6.93]	219,5 [8.64]	34,8 [1.37]
HW... 300	300	182,5 [7.19]	226,0 [8.89]	41,4 [1.63]
HW... 315	315	184,5 [7.26]	228,0 [8.98]	43,5 [1.71]
HW... 350	350	189,0 [7.44]	232,5 [9.15]	48,0 [1.89]
HW... 370	370	192,0 [7.56]	235,5 [9.27]	51,0 [2.01]
HW... 400	400	196,0 [7.72]	239,5 [9.43]	54,8 [2.16]
HW... 470	470	206,0 [8.11]	249,5 [9.82]	65,0 [2.56]
HW... 500	500	210,5 [8.29]	254,0 [10.00]	69,4 [2.73]
HW... 535	535	215,0 [8.46]	258,8 [10.19]	74,1 [2.92]
HW... 550	550	217,0 [8.54]	260,5 [10.26]	76,0 [2.99]
HW... 600	600	226,6 [8.92]	267,1 [10.52]	82,6 [3.25]
HW... 750	750	244,5 [9.63]	288,0 [11.34]	104,0 [4.09]

*For LSV option the dimension L is 3 mm [.118 in] greater.

**Pressure Settings at Flow Q=5 lpm [1.32 GPM]
32 mm²/s [150 SUS]; 50°C [122°F]**

- 1 - 70 bar [1015 PSI]
- 2 - 100 bar [1450 PSI]
- 3 - 140 bar [2030 PSI]
- 4 - 170 bar [2470 PSI]
- 5 - 210 bar [3050 PSI]

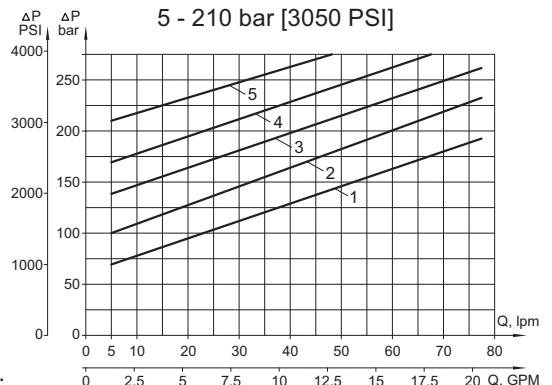

DIMENSIONS and MOUNTING DATA

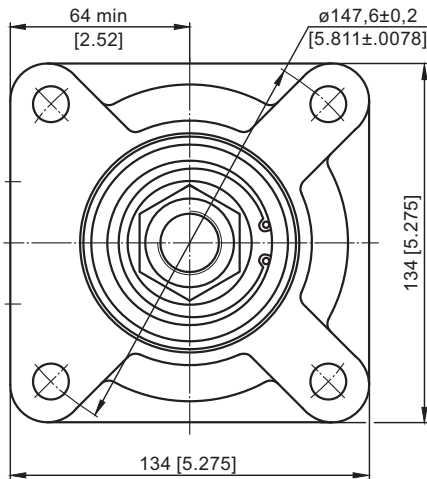

D Wheel mount

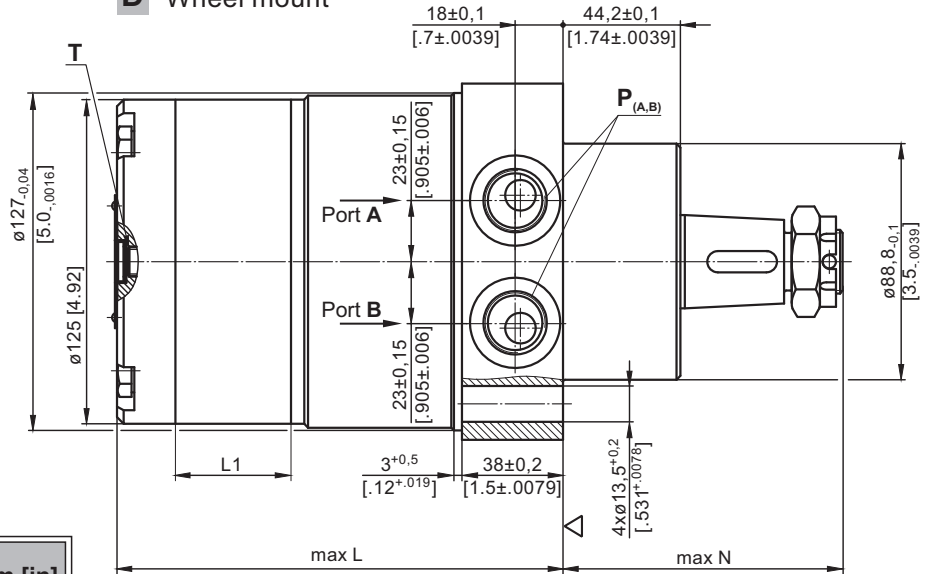

Type	*L, mm [in]		L ₁ , mm [in]
	HWD	HWV	
HW... 80	136,0 [5.35]	134,0 [5.28]	11,0 [.43]
HW... 100	139,0 [5.47]	137,0 [5.39]	14,0 [.55]
HW... 125	142,5 [5.61]	140,5 [5.53]	17,4 [.68]
HW... 160	147,0 [5.79]	145,0 [5.71]	21,8 [.86]
HW... 200	153,0 [6.02]	151,0 [5.94]	27,8 [1.09]
HW... 235	158,0 [6.22]	155,5 [6.12]	32,5 [1.28]
HW... 250	160,0 [6.30]	158,0 [6.22]	34,8 [1.37]
HW... 300	166,5 [6.56]	164,5 [6.46]	41,4 [1.63]
HW... 315	169,0 [6.65]	166,5 [6.56]	43,5 [1.71]
HW... 350	173,5 [6.83]	171,0 [6.73]	48,0 [1.89]
HW... 370	176,5 [6.95]	174,0 [6.85]	51,0 [2.01]
HW... 400	180,0 [7.09]	178,0 [7.01]	54,8 [2.16]
HW... 470	190,5 [7.50]	188,0 [7.40]	65,0 [2.56]
HW... 500	194,5 [7.66]	192,5 [7.58]	69,4 [2.73]
HW... 535	199,5 [7.85]	197,0 [7.76]	74,1 [2.92]
HW... 550	201,5 [7.93]	199,0 [7.83]	76,0 [2.99]
HW... 600	207,1 [8.15]	206,0 [8.11]	82,6 [3.25]
HW... 750	229,0 [9.02]	227,5 [8.96]	104,0 [4.09]

Note: For N see pages 120, 121 and 122.

▽ - Motor mounting surface

	Versions	
	2	4
P _(A,B)	2xG½	2x7/8-14UNF, O-ring
T	G¼	7/16-20UNF, O-ring

Standard Rotation
Viewed from Shaft End
Port A Pressurized - **CW**
Port B Pressurized - **CCW**

Reverse Rotation
Viewed from Shaft End
Port A Pressurized - **CCW**
Port B Pressurized - **CW**



V Wheel mount, four holes, manifold 4xM6

	Versions	
	2	4
T	G¼	7/16-20UNF, O-ring

* For LSV option the dimension L is 3 mm [1.18 in] greater.

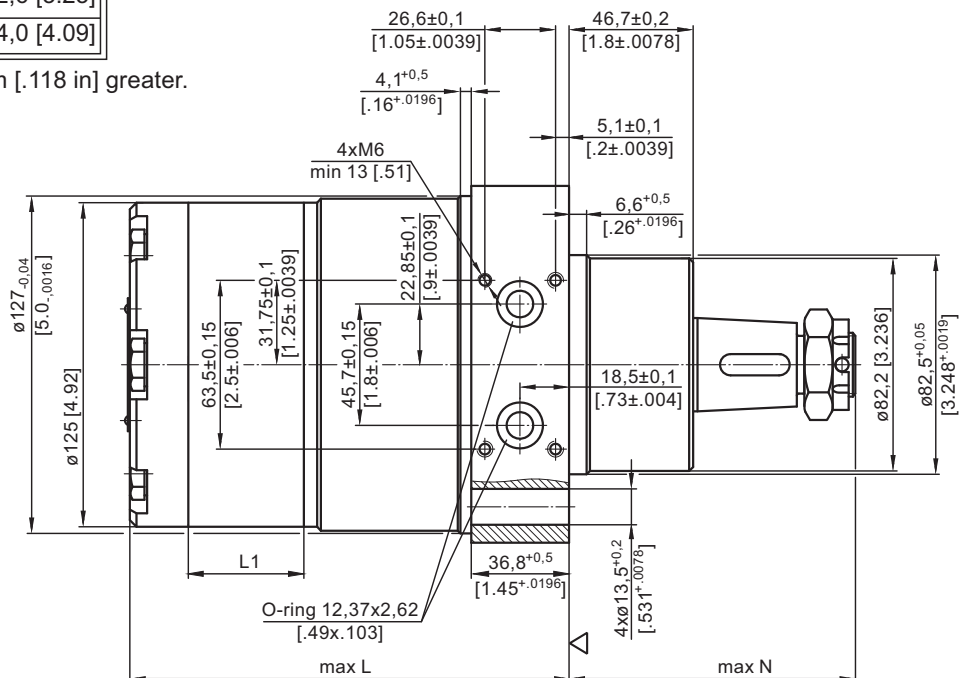
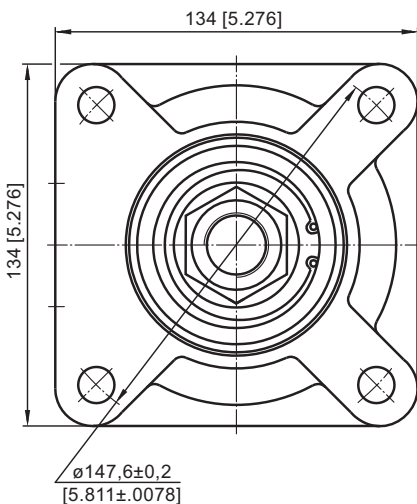

DIMENSIONS and MOUNTING DATA

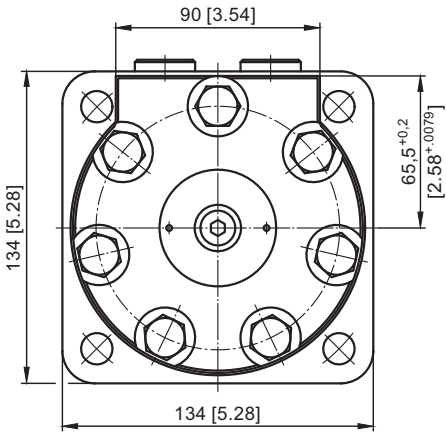

HWF...7,8,9,10

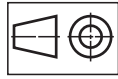
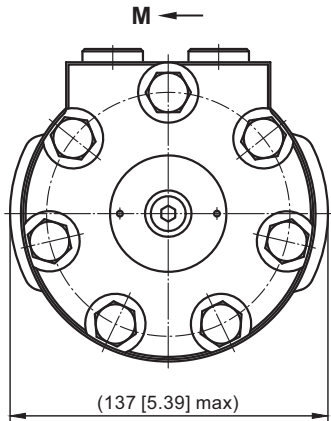

mm [in]

HW...7

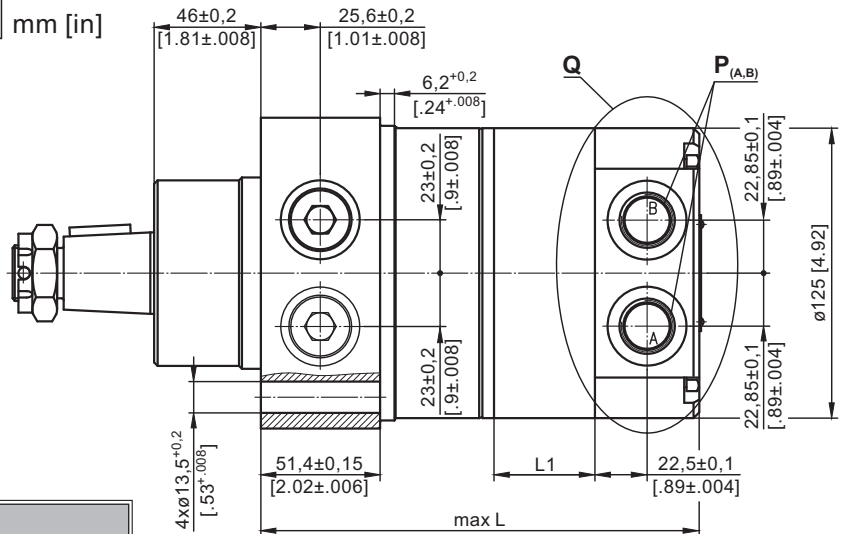
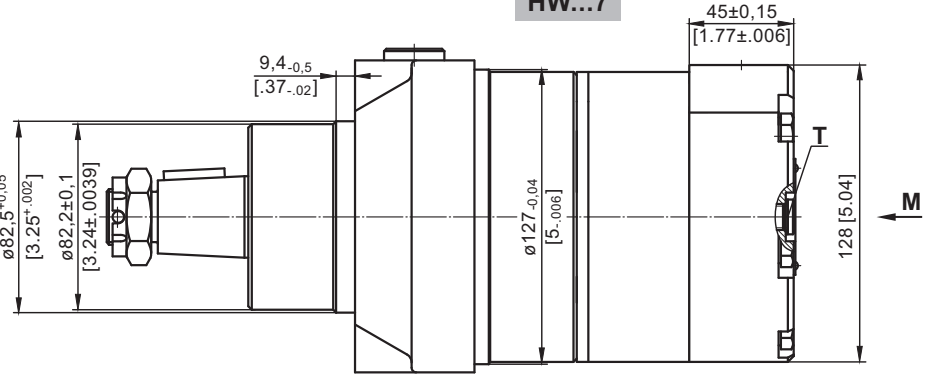

Versions						
	7	8	9 2	9 4	10 2	10 4
P_(A,B)	2xG $\frac{1}{2}$	2x $\frac{1}{8}$ -14UNF, O-ring	2xØ9 O-ring 12,37x2,62 [.49x.103]	2xØ9 O-ring 12,37x2,62 [.49x.103]	2xM16x1,5 O-ring 18x2 [.709x.787]	2xM16x1,5 O-ring 18x2 [.709x.787]
T	G $\frac{1}{4}$	$\frac{1}{16}$ -20UNF, O-ring	G $\frac{1}{4}$	$\frac{1}{16}$ -20UNF, O-ring	G $\frac{1}{4}$	$\frac{1}{16}$ -20UNF, O-ring

Type	*L, mm [in]		L ₁ , mm [in]
	HW(S)...7,8,9,10	HWF...7,8,9,10	
HW... 80	157,5 [6.20]	200,5 [7.89]	11,0 [.43]
HW...100	160,5 [6.32]	203,5 [8.01]	14,0 [.55]
HW...125	164,0 [6.46]	207,0 [8.15]	17,4 [.68]
HW...160	168,0 [6.61]	211,0 [8.31]	21,8 [.86]
HW...200	174,0 [6.85]	217,0 [8.54]	27,8 [1.09]
HW...235	179,0 [7.05]	222,0 [8.74]	32,5 [1.28]
HW...250	181,0 [7.13]	224,0 [8.82]	34,8 [1.37]
HW...300	187,5 [7.38]	230,5 [9.07]	41,4 [1.63]
HW...315	190,0 [7.48]	233,0 [9.17]	43,5 [1.71]
HW...350	194,5 [7.66]	237,5 [9.35]	48,0 [1.89]
HW...370	197,5 [7.78]	240,5 [9.47]	51,0 [2.01]
HW...400	201,0 [7.91]	244,0 [9.61]	54,8 [2.16]
HW...470	211,5 [8.33]	254,5 [10.02]	65,0 [2.56]
HW...500	216,0 [8.50]	259,0 [10.20]	69,4 [2.73]
HW...535	220,5 [8.68]	263,5 [10.37]	74,1 [2.92]
HW...550	222,5 [8.76]	265,5 [10.45]	76,0 [2.99]
HW...600	229,0 [9.02]	272,0 [10.71]	82,6 [3.25]
HW...750	250,5 [9.86]	293,5 [11.56]	104 [4.09]

* For LSV option the dimension L is 3 mm [1.18 in] greater.

Q (version 9 2)

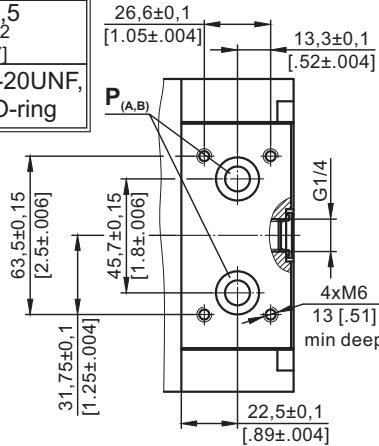

Q (version 9 4)

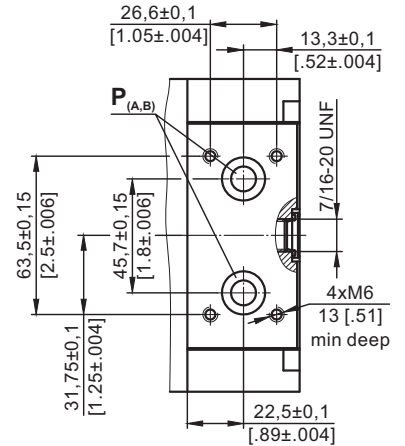

Q (version 10 2)

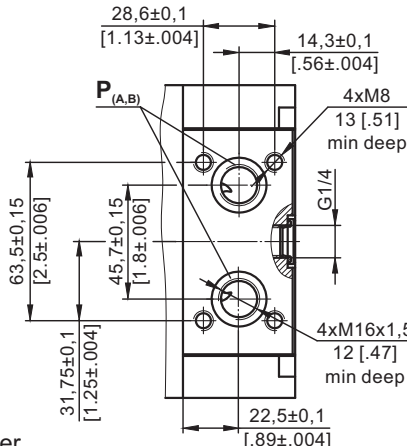

Q (version 10 4)

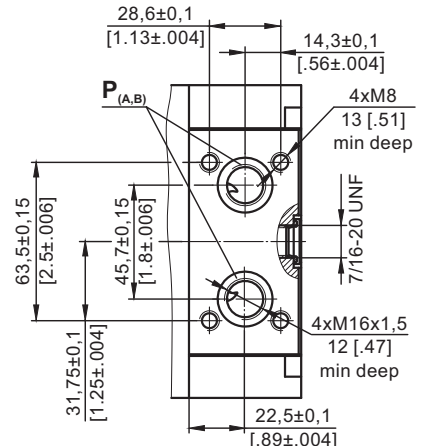

PERMISSIBLE SHAFT LOADS

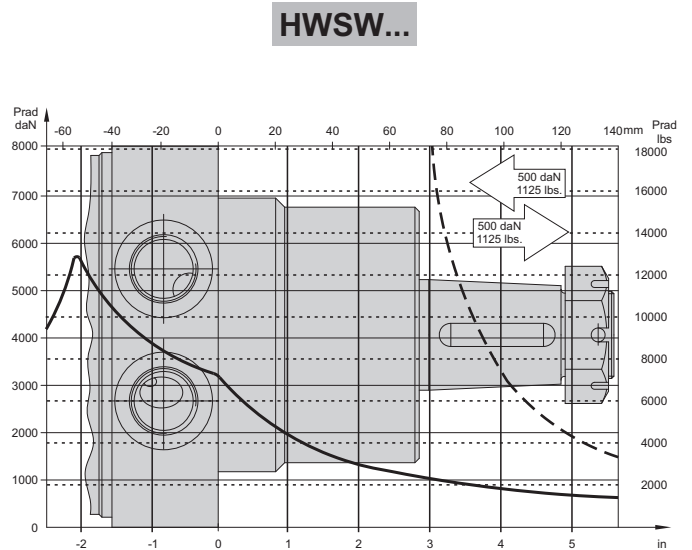
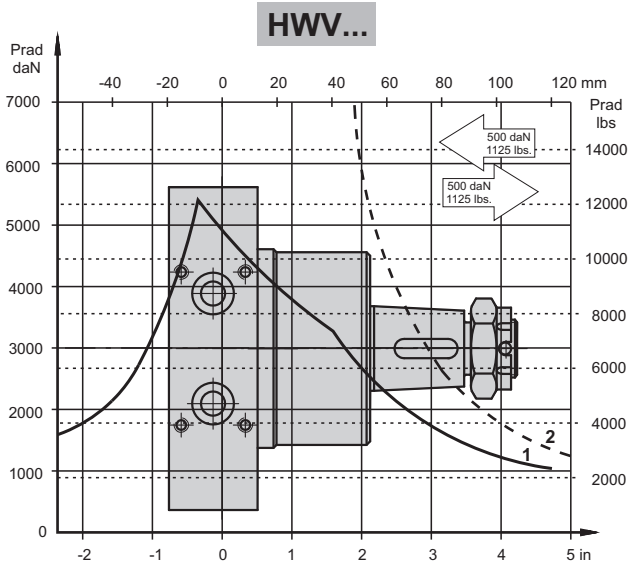
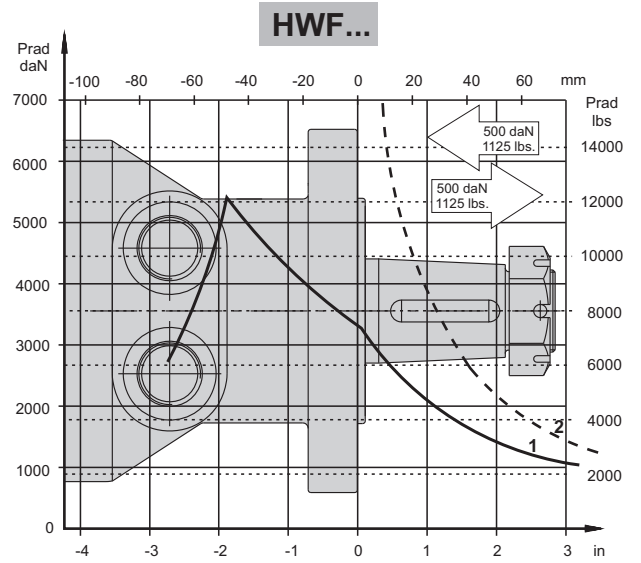
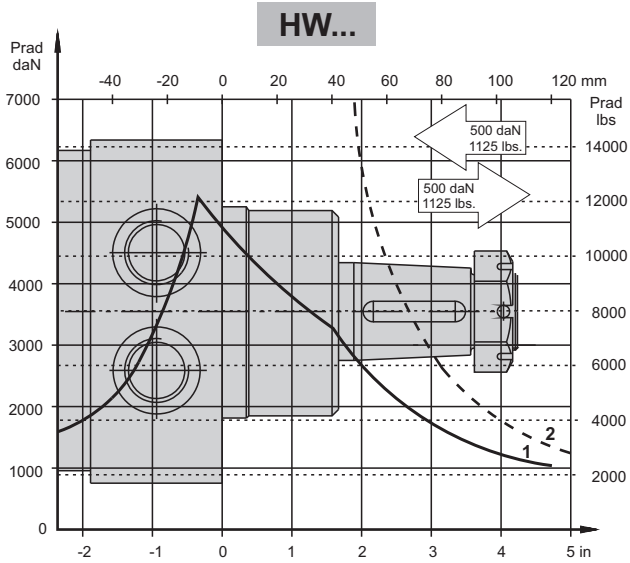

- 1 - Bearing curve: The curve applies to a B10 bearing life of 2000 hours at 100 RPM.
- 2 - Shaft curve: The curve represents Max. permissible radial shaft load with safety factor 3:1.

MAX. PERMISSIBLE SHAFT SEAL PRESSURE

HW, HWF, HWS, HWD,
HWV, HWSW,
HW(S)(F)...7,8,9,10

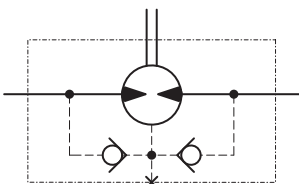

HWFR, HWSR, HWSWR

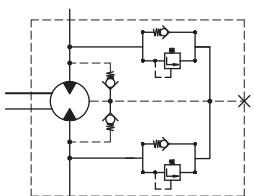

HW...U(Q) motors with drain connection:

The shaft seal pressure equals the pressure in the drain line.

- 1 - extreme high pressure "Q" version
 - 2 - high pressure "U" version
 - 3 - standard version
 - 4 - shaft "C" version
- - continuous operations
- - - - - intermittent operations

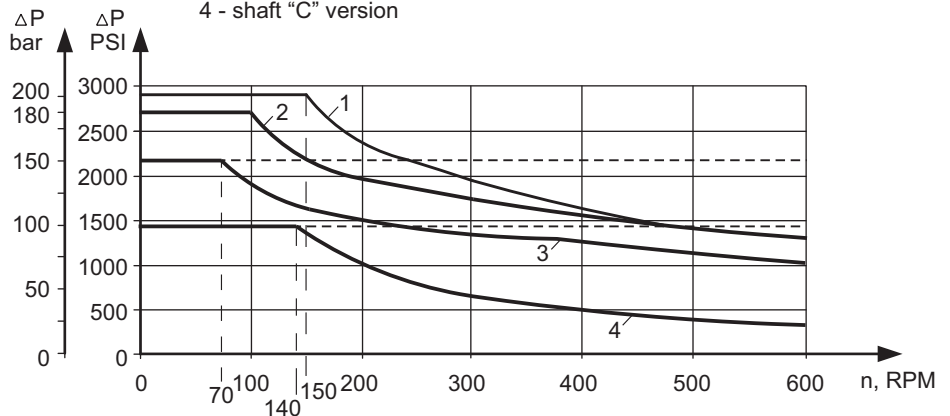

SHAFT EXTENSIONS

C - 1½" [38,1] straight, Parallel key 3/8"x 3/8"x1½" BS46
Max. Torque 120 daNm [10630 lb-in]

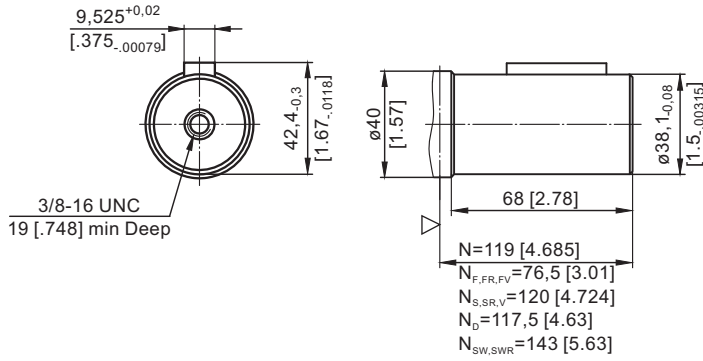

CO - ø25, straight, Parallel key A8x7x32 DIN 6885
Max. Torque 40 daNm [3540 lb-in]

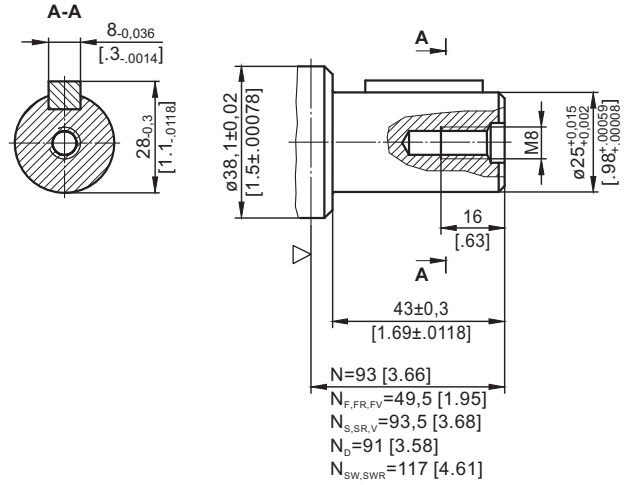

K - 1¼" [31,75] straight, Parallel key 5/16"x 5/16"x1½" BS46
Max. Torque 77 daNm [6815 lb-in]

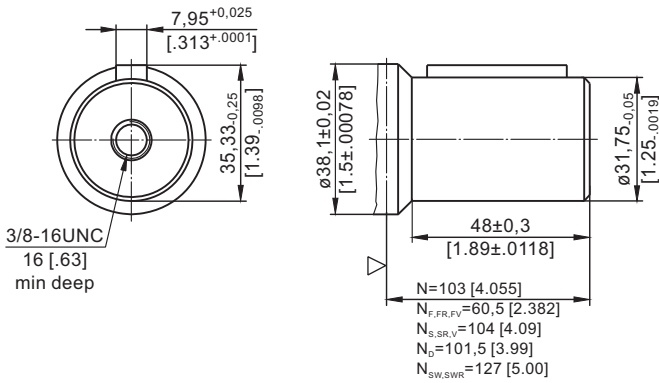

M - ø32 straight, Parallel key A10x8x32 DIN 6885
Max. Torque 77 daNm [6815 lb-in]

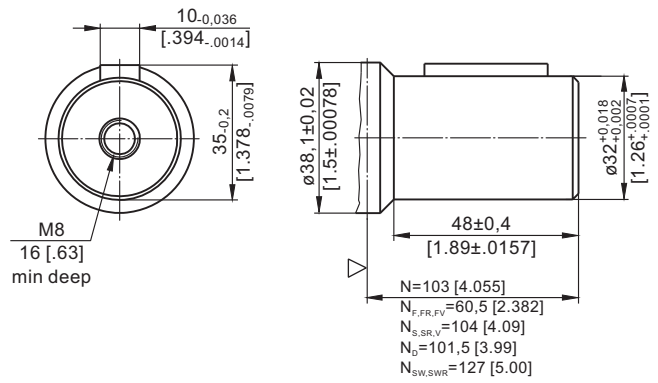

H - 1⅜" [35] straight, Parallel key 5/16"x 5/16"x1½" BS46
Max. Torque 90 daNm [7965 lb-in]

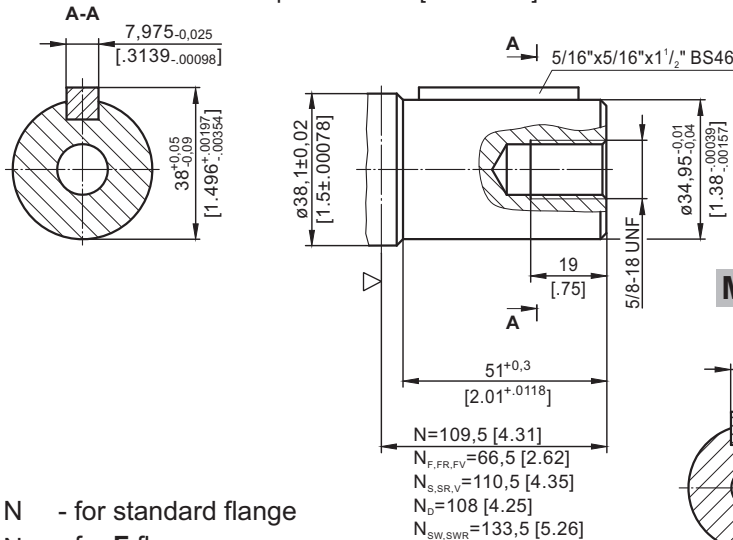

▽ - Motor Mounting Surface

MP - ø32 straight, Parallel key A10x8x45 DIN 6885
Max. Torque 85 daNm [7520 lb-in]

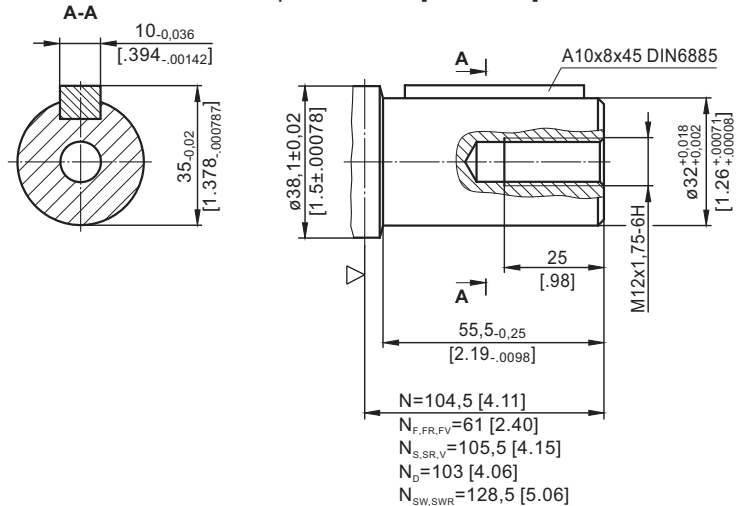

- N - for standard flange
- N_F - for F flange
- N_{FR} - for FR flange
- N_{FV} - for FV flange
- N_S - for S flange
- N_{SR} - for SR flange
- N_D - for D flange
- N_V - for V flange
- N_{SW} - for SW flange
- N_{SWR} - for SWR flange

SH - $\varnothing 1"$ splined BS 2059, SAE 6B
Max. Torque 40 daNm [3540 lb-in]

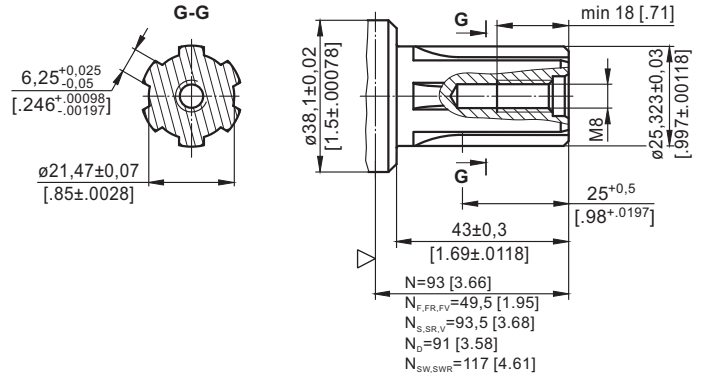

L - $\varnothing 1\frac{1}{4}"$ [31,75] splined 14T, DP12/24 ANSI B92.1-1976
Max. Torque 95 daNm [8410 lb-in]

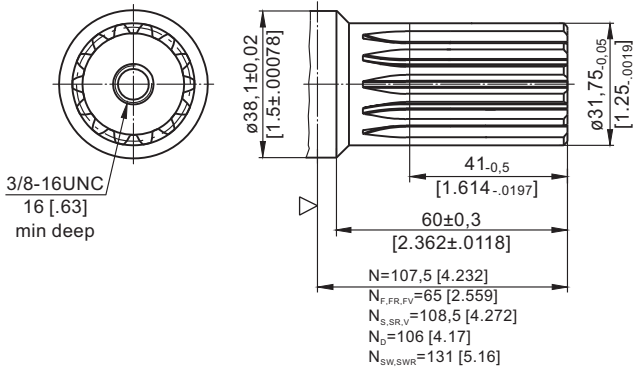

KB - $\varnothing 35$ tapered 1:10, Parallel key $\frac{5}{16}" \times \frac{5}{16}" \times 1\frac{1}{4}"$ BS46
Max. Torque 95 daNm [8410 lb-in]

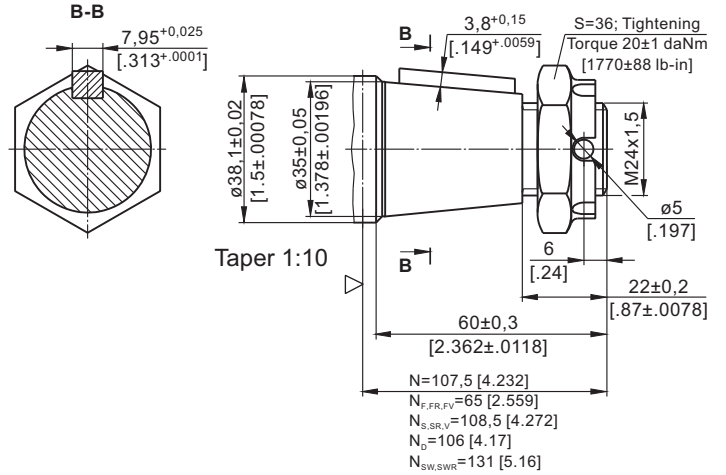

T - $1\frac{1}{2}"$ [38,1] tapered 1:8, Parallel key $\frac{5}{16}" \times \frac{5}{16}" \times 1\frac{1}{4}"$ BS46
Max. Torque 120 daNm [10620 lb-in]

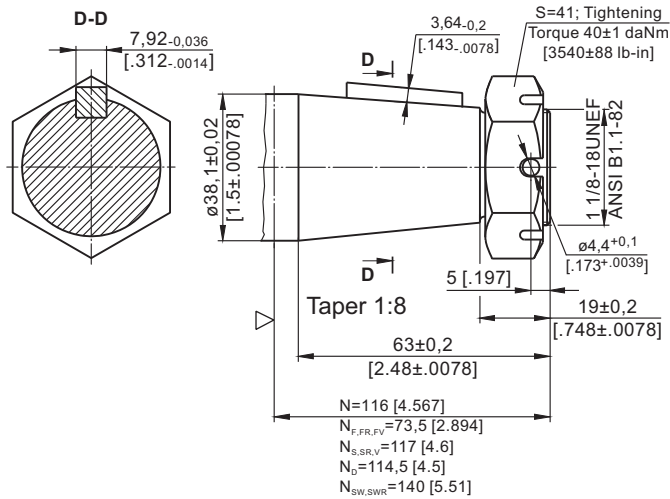

R - $1\frac{1}{4}"$ [31,75] tapered 1:8, Parallel key $\frac{5}{16}" \times \frac{5}{16}" \times 1"$ BS46
Max. Torque 95 daNm [8410 lb-in]

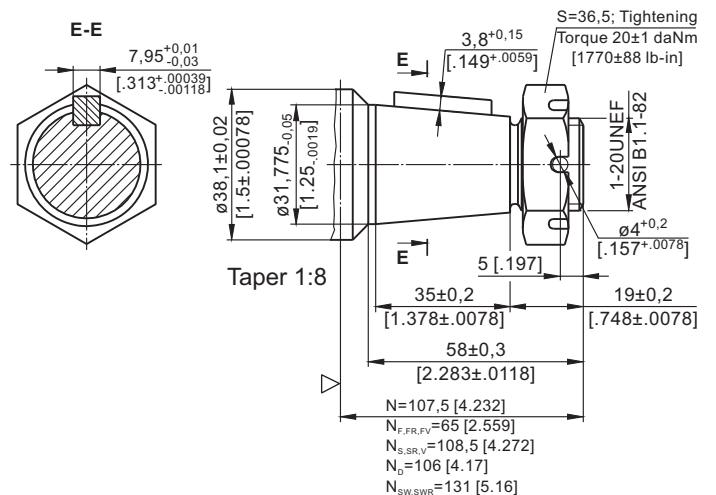

- N - for standard flange
- N_F - for F flange
- N_{FR} - for FR flange
- N_{FV} - for FV flange
- N_S - for S flange
- N_{SR} - for SR flange
- N_D - for D flange
- N_V - for V flange
- N_{SW} - for SW flange
- N_{SWR} - for SWR flange



▽ - Motor Mounting Surface

ORDER CODE

	1	2	3	4	5	6	7	8	9
HW								/	

Pos.1 - Mounting Flange

- omit - Wheel mount, four holes
- E** - Wheel mount, four holes, rear ports
- F** - Magneto mount, six holes
- FR** - Magneto mount, six holes, relief valves
- FV^{1)*}** - Magneto mount, six holes, manifold 4xM6
- FE** - Magneto mount, six holes, rear ports
- S** - Wheel mount, four holes
- SR** - Wheel mount, four holes, relief valves
- SW** - Wheel mount, four holes; mounting on $\varnothing 95,3$ [3.75]
- SWR** - Wheel mount, four holes; mounting on $\varnothing 95,3$ [3.75], relief valves
- SE** - Wheel mount, four holes, rear ports
- D** - Wheel mount, four holes; mounting on $\varnothing 88,8$ [3.5]
- V^{1)*}** - Wheel mount, four holes, manifold 4xM6

Pos.2 - Displacement code

- 80** - 79,7 cm³/rev [4.86 in³/rev]
- 100** - 101,4 cm³/rev [6.19 in³/rev]
- 125** - 126,0 cm³/rev [7.69 in³/rev]
- 160** - 157,8 cm³/rev [9.63 in³/rev]
- 200** - 201,3 cm³/rev [12.28 in³/rev]
- 235** - 235,3 cm³/rev [14.36 in³/rev]
- 250** - 252,0 cm³/rev [15.38 in³/rev]
- 300** - 300,0 cm³/rev [18.31 in³/rev]
- 315** - 314,9 cm³/rev [19.22 in³/rev]
- 350** - 347,8 cm³/rev [21.22 in³/rev]
- 370** - 369,0 cm³/rev [22.52 in³/rev]
- 400** - 396,8 cm³/rev [24.21 in³/rev]
- 470** - 470,6 cm³/rev [28.72 in³/rev]
- 500** - 502,4 cm³/rev [30.66 in³/rev]
- 535** - 535,0 cm³/rev [32.65 in³/rev]
- 550** - 550,0 cm³/rev [33.56 in³/rev]
- 600** - 598,9 cm³/rev [36.55 in³/rev]
- 750** - 753,8 cm³/rev [45.99 in³/rev]

Pos.3 - Shaft Extensions^{2)*}

- K** - 1 1/4" [$\varnothing 31,75$] straight, Parallel key $5/16"$ x $5/16"$ x $1 1/2"$ BS46
- KB** - $\varnothing 35$ tapered 1:10, Parallel key $5/16"$ x $5/16"$ x $1 1/4"$ BS46
- L** - 1 1/4" [$\varnothing 31,75$] splined 14T, DP12/24 ANSI B92.1-1976
- M** - $\varnothing 32$ straight, Parallel key A10x8x32 DIN 6885
- MP** - $\varnothing 32$ straight, Parallel key A10x8x45 DIN 6885
- R** - 1 1/4" [$\varnothing 31,75$] tapered 1:8, Parallel key $5/16"$ x $5/16"$ x $1"$ BS46
- T** - 1 1/2" [$\varnothing 38,1$] tapered 1:8, Parallel key $5/16"$ x $5/16"$ x $1 1/4"$ BS46
- C** - 1 1/2" [$\varnothing 38,1$] straight, Parallel key $3/8"$ x $3/8"$ x $1 1/2"$ BS46
- CO** - $\varnothing 25$, straight, Parallel key A8x7x32 DIN 6885
- H** - 1 3/8" [$\varnothing 35$] straight, Parallel key $5/16"$ x $5/16"$ x $1 1/2"$ BS46
- SH** - 1" [$\varnothing 25,32$] splined BS 2059, SAE 6B

Pos.4 - Ports

- 2** - side ports, 2xG1/2, G1/4, BSP thread, ISO 228
- 4** - side ports, 2x7/8-14 UNF, O-ring, 7/16-20 UNF
- 5^{3)*}** - rear ports, 2xG3/8, G1/4, BSP thread, ISO 228
- 6^{3)*}** - rear ports, 2x9/16-18 UNF, O-ring, 7/16-20 UNF
- 7^{8)*}** - side ports, 2xG1/2 thread in the cover
- 8^{8)*}** - side ports, 2x7/8-14 UNF, O-ring thread in the cover
- 9^{8)*}** - side ports, for valve mounting in the cover
- 10^{8)*}** - side ports, for valve mounting and 2xM16 in the cover

Pos.5 - Drain line

- omit - For versions 2,4,5,6,7 and 8
- 2** - G1/4, BSP thread, ISO 228
- 4** - 7/16-20 UNF

Pos.6 - Shaft Seal Version

- omit - Standard shaft seal up to 150 bar [2175 PSI]
- U** - High pressure shaft seal up to 180 bar [2610 PSI]
- Q** - Extreme high pressure shaft seal up to 200 bar [2900 PSI]

Pos.7 - Additional Options^{4)*, 5)*, 6)*} [see page 125]

Pos.8 - Valves Pressure Range, bar^{7)*}

- / - 70, 100, 140, 170, 210

Pos.9 - Design Series

- omit - Factory specified

- NOTES:**
- 1)* Flanges **V** and **FV** are for versions 2 and 4 - drainage only!
 - 2)* The permissible output torque for shafts must not be exceeded!
 - 3)* For **E**-version only!
 - 4)* If the code on pos.7 is not specified in the order, it will be considered as LL-option.
 - 5)* Colour at customer's request.
 - 6)* Non painted feeding surfaces, colour at customer's request.
 - 7)* For **SR** and **FR** only!
 - 8)* Port versions 7,8,9 and 10 are available with HW(S)(F) flanges only!

E-version and 7,8,9 and 10 are not available with **SR**, **SWR** and **FR!!!**
HW...R-version is not available with "RS"!

The hydraulic motors are mangano-phosphatized as standard.

MOTOR ADDITIONAL OPTIONS

Additional Options Description	Order Code	Motor type														
		MM	MP	MPW	MP(W)N	MR	MRN	MRB	SP, SR	PL	RL	PK(Q)	RK	RW	MH	HW
Speed Sensor*	RS	O	O	-	-	O	-	-	-	-	-	-	-	-	O	O****
Tacho connection	T	-	-	-	-	O	O	-	-	-	-	-	-	-	O	-
Low Leakage	LL	O	-	-	-	O	O	-	-	-	O	-	O	O	O	O
Low Speed Valving	LSV	-	-	-	-	O	-	-	-	-	-	-	-	-	O	O
Free Running	FR	O	O	O	O	O	O	-	-	O	O	O	O	O	O	O
Reverse Rotation	R	O	O	O	O	O	O	O	O	O	O	O	O	O	O	O
Paint**	P	O	O	O	O	O	O	O	O	O	O	O	O	O	O	O
Corrosion Protected Paint**	PC	O	O	O	O	O	O	O	O	O	O	O	O	O	O	O
Special Paint***	PS	O	O	O	O	O	O	O	-	O	O	O	O	O	O	O
	PCS	O	O	O	O	O	O	O	O	O	O	O	O	O	O	O
Check Valves		S	S****	S****	S	S****	S	S	S	S	S	S	S	S****	S****	S

O	Optional
-	Not applicable
S	Standard

- * For sensor ordering see pages [126÷127](#).
- ** Colour at customer's request.
- *** Non painted feeding surfaces, colour at customer's request.
- **** Without check valves for "U" shaft seal versions.
- ***** RS option is not available at HW...R (with relief valves).

MOTORS WITH SPEED SENSOR

MM...RS

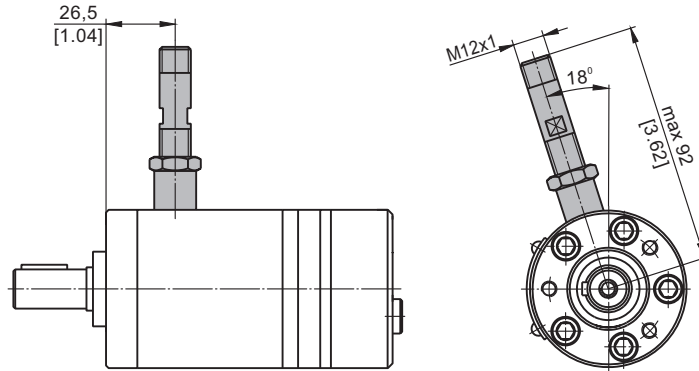

MP...RS and MR...RS

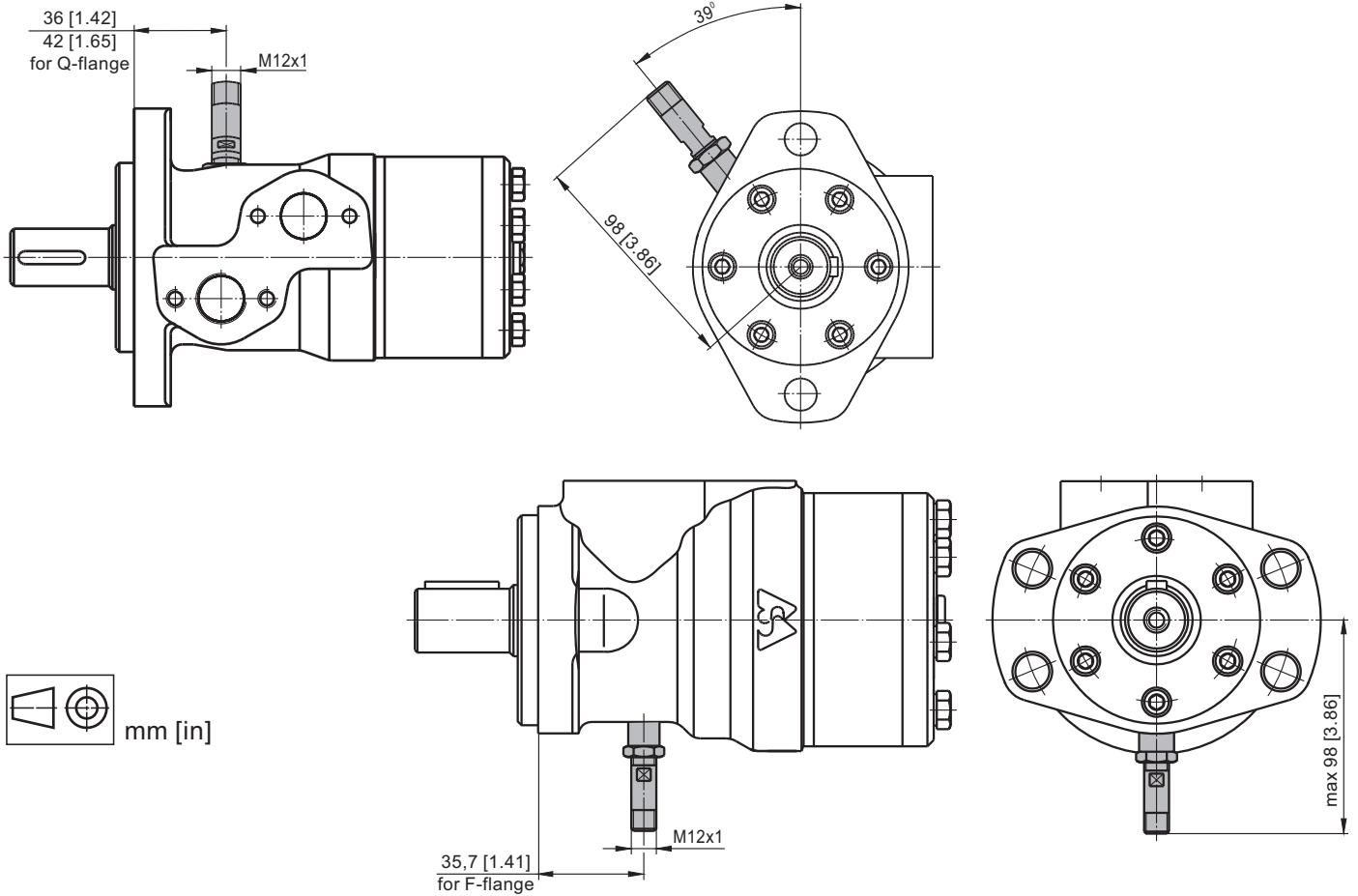

MH...RS

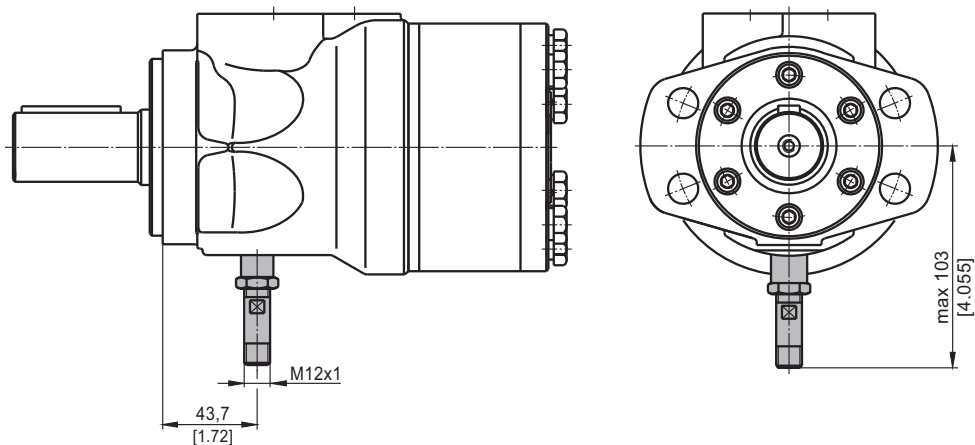

HW...RS

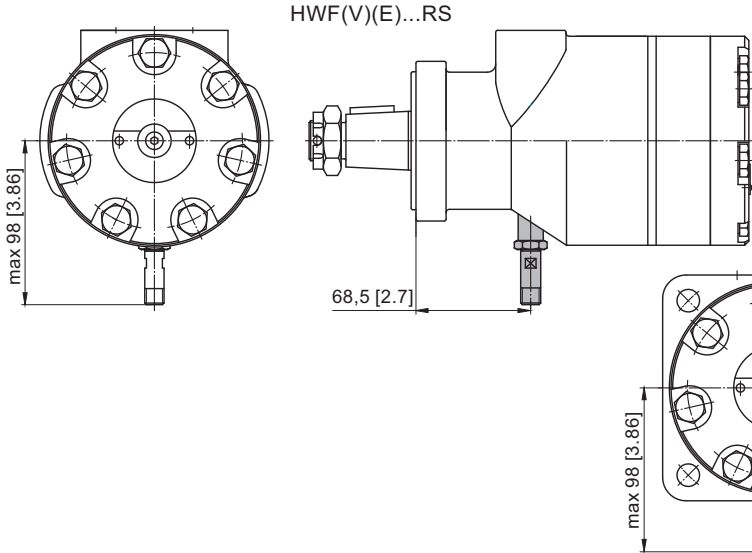

RS option is not available at HW...R (with relief valves).

HW(S)(D)(SW)(V)(E)...RS

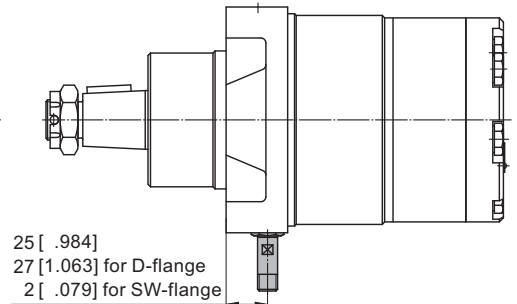

TECHNICAL DATA OF THE SPEED SENSOR

Technical data

Frequency range	0...15 000 Hz
Output	Universal PUSH PULL
Power supply	10-30 VDC
Current input	<20 mA (@24 VDC)
Maximum output current	500 mA
Ambient Temperature	-40...+125°C [-40...+257°F]
Protection	IP 67
Plug connector	M12-Series
Mounting principle	ISO 6149

Output signal

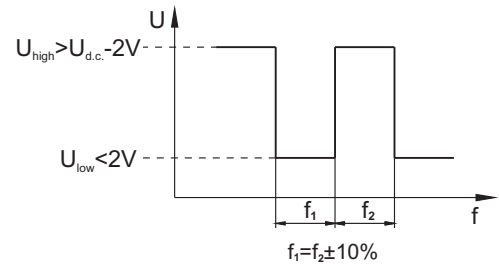

Load max.: $i_{high} = i_{low} < 50\text{mA}$

Motor type	MM	MP	MR	MH	HW
Pulses per revolution	30	36	36	42	12

Wiring diagrams

PNP

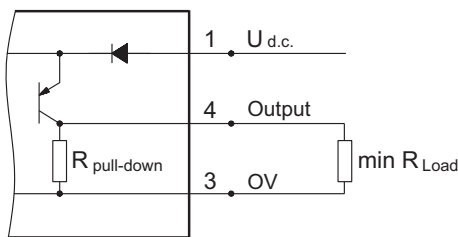

NPN

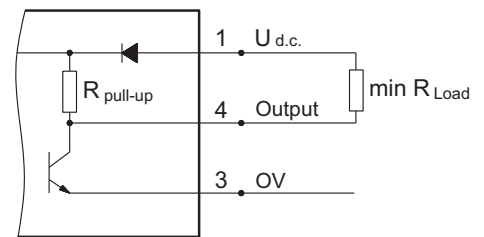

$$R_{Load} [k\Omega] = U_{d.c.} [V] / I_{max} [mA]$$

Stick type

Order Code for Speed Sensor

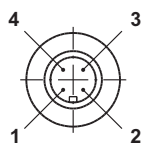

Terminal No.	Connection	Cable Output
1	U _{d.c.}	Brown
2	No connection	White
3	0V	Blue
4	Output signal	Black

Sensor Code	Electric connection
RS	Connector BINDER 713 series
RSL2,5	Cable output 3x0,25; 2,5 m [98 in] long
RSL3,5	Cable output 3x0,25; 3,5 m [138 in] long
RSL5	Cable output 3x0,25; 5 m [196 in] long
RSL10	Cable output 3x0,25; 10 m [394 in] long

NOTE: * - The speed sensor is not fitted at the factory, but is supplied in a plastic bag with the motor. For installation see enclosed instructions.

APPLICATION CALCULATION

VEHICLE DRIVE CALCULATIONS

1. Motor speed: n [RPM]

$$n = \frac{2.65 \times V_{km} \times i}{R_m} \quad n = \frac{168 \times V_{mi} \times i}{R_{in}}$$

V_{km} - vehicle speed, km/h;

V_{mi} - vehicle speed, mil/h;

R_m - wheel rolling radius, m;

R_{in} - wheel rolling radius, in;

i - gear ratio between motor and wheels.

If no gearbox, use $i=1$.

2. Rolling resistance: RR, daN [lbs]

The resistance force resulted in wheels contact with different surfaces:

$$RR = G \times \rho$$

G - total weight loaded on vehicle, daN [lbs];

ρ - rolling resistance coefficient (Table 1).

Table 1

Rolling resistance coefficient In case of rubber tire rolling on different surfaces	
Surface	ρ
Concrete- faultless	0.010
Concrete- good	0.015
Concrete- bad	0.020
Asphalt- faultless	0.012
Asphalt- good	0.017
Asphalt- bad	0.022
Macadam- faultless	0.015
Macadam- good	0.022
Macadam- bad	0.037
Snow- 5 cm	0.025
Snow- 10 cm	0.037
Polluted covering- smooth	0.025
Polluted covering- sandy	0.040
Mud	0.037÷0.150
Sand- Gravel	0.060÷0.150
Sand- loose	0.160÷0.300

3. Grade resistance: GR, daN [lbs]

$$GR = G \times (\sin\alpha + \rho \times \cos\alpha)$$

α - gradient negotiation angle (Table 2).

Table 2

Grade %	α Degrees	Grade %	α Degrees
1%	0° 35'	12%	6° 5'
2%	1° 9'	15%	8° 31'
5%	2° 51'	20%	11° 19'
6%	3° 26'	25%	14° 3'
8%	4° 35'	32%	18°
10%	5° 43'	60%	31°

4. Acceleration force: FA, daN [lbs]

Force FA necessary for acceleration from 0 to maximum speed v and time t can be calculated with a formula:

$$FA = \frac{V_{km} \times G}{36 \times t}, [\text{daN}] \quad FA = \frac{V_{mi} \times G}{22 \times t}, [\text{lbs}]$$

FA - acceleration force, daN [lbs];

t - time, [s]

5. Tractive effort: DP, daN [lbs]

Tractive effort DP is the additional force of trailer. This value will be established as follows:

- acc. to constructor's assessment;

- as calculating forces in items 2, 3 and 4 of trailer;

the calculated sum corresponds to the tractive effort requested.

6. Total tractive effort: TE, daN [lbs]

Total tractive effort TE is total effort necessary for vehicle motion; that the sum of forces calculated in items from 2 to 5 and increased with 10% because of air resistance.

$$TE = 1,1 \times (RR + GR + FA + DP)$$

RR - force acquired to overcome the rolling resistance;

GR - force acquired to slope upwards;

FA - force acquired to accelerate (acceleration force);

DP - additional tractive effort (trailer).

7. Motor Torque moment: M, daNm [lb-in]

Necessary torque moment for every hydraulic motor:

$$M = \frac{TE \times R_m [R_{in}]}{N \times i \times \eta_M}$$

N - motor numbers;

η_M - mechanical gear efficiency (if it is available).

8. Cohesion between tire and road covering:

M_w , daNm [lb-in]

Necessary torque moment for every hydraulic motor:

$$M_w = \frac{G_w \times f \times R_m [R_{in}]}{i \times \eta_M}$$

To avoid wheel slipping, the following condition should be observed $M_w > M$

f - frictional factor;

G_w - total weight over the wheels, daN [lbs].

Table 3

Surface	Frictional factor f
Steel on steel	0.15 ÷ 0.20
Rubber tire on polluted surface	0.5 ÷ 0.7
Rubber tire on asphalt	0.8 ÷ 1.0
Rubber tire on concrete	0.8 ÷ 1.0
Rubber tire on grass	0.4

9. Radial motor loading: P_{rad} , daN [lbs]

When motor is used for vehicle motion with wheels mounted directly on motor shaft, the total radial loading of motor shaft P_{rad} is a sum of motion force and weight force acting on one wheel.

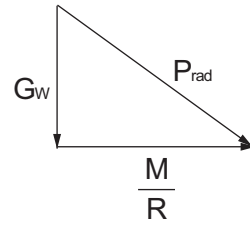

G_w - weight held by wheel;

P_{rad} - total radial loading of motor shaft;

M/R - motion force.

$$P_{rad} = \sqrt{G_w^2 + \left(\frac{M}{R}\right)^2}$$

In accordance with calculated loadings the suitable motor from the catalogue is selected.

DRAINAGE SPACE AND DRAINAGE PRESSURE

Advantages in oil drainage from drain space: Cleaning; Cooling and Seal lifetime prolonging.

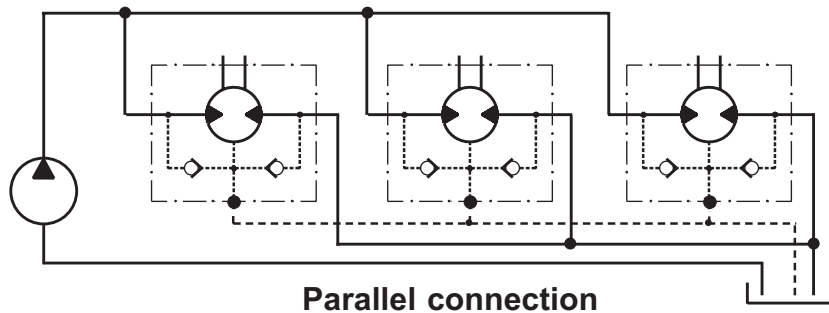
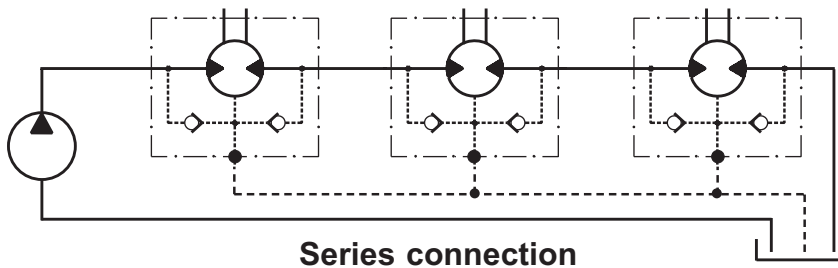

WARRANTY

M+S Hydraulic warrants, that its products, supplied directly to original equipment manufacturer, authorized distributor or other customer, will be free of defects in material or workmanship at the time of shipment from M+S Hydraulic and will conform to the products technical documentation (drawings and specifications) under sale agreement with Buyer.

This warranty will apply only to defects appearing within applicable Warranty period, mentioned below. If Buyer notifies M+S Hydraulic within the Warranty period about any such defects, M+S, at its sole option will replace or repair the defective products or their parts found by M+S Hydraulic to be defective in material or workmanship.

THE FOREGOING LIMITED WARRANTY IS AVAILABLE ONLY IF "M+S HYDRAULIC" IS PROMPTLY NOTIFIED IN WRITTEN OF THE ALLEGED DEFECT AND DOES NOT COVER FAILURE TO FUNCTION CAUSED BY DAMAGE TO THE PRODUCT, IMPROPER INSTALLATION, UNREASONABLE USE OR ABUSE OF THE PRODUCT, FAILURE TO PROVIDE OR USE OF IMPROPER MAINTENANCE OR USUAL, DEGRADATION OF THE PRODUCT DUE TO PHYSICAL ENVIRONMENTS OF AN USUAL NATURE. THE FOREGOING REMEDIES ARE THE SOLE AND EXCLUSIVE REMEDIES AVAILABLE TO CUSTOMER. To facilitate the inspection, M+S Hydraulic may require return of the product/part, which Buyer claims to be defective.

M+S Hydraulic shall not be liable for labor costs or any other expenses incurred during the disassembling or reinstalling of the product/part.

In case the claimed products are returned to M+S Hydraulic in bad condition: dirty, disassembled, with damaged or missing parts during transportation, the warranty will be considered as not applicable and the products will not be liable to repair.

Warranty periods

New products: The Warranty period is limited to 24 consecutive months (2 years) from the date of production of the product.

Repaired products: If the product is repaired in M+S Hydraulic during its warranty period, the warranty period of the repaired item shall continue for the balance of original Warranty period or for a period equal to 50% of the original new product Warranty period, whichever is later.

Spare parts: The Warranty period for Spare parts is 12 consecutive months (1 year) from the dispatch date of such parts from M+S Hydraulic.

LIMITATION OF LIABILITY M+S Hydraulic's liability for claim of any kind, for loss or damage arising out of, connected with or resulting from an order, or from the performance or branch thereof, or from the design, manufacture, sale delivery, operation or use of any of its products shall be limited to, at M+S 's sole option, replacement, repair of any defective product or the issuance of a credit to Customer against any future purchases. Cash refunds will not be made under any circumstances and Customer will not be entitled to recover any damages of any kind against M+S Hydraulic, including but not limited to incidental or consequential damages, whether direct or indirect, known or unknown, foreseen or unforeseen.



M+S HYDRAULIC

68, Kozloduy St., 6100 Kazanlak, Bulgaria

Tel.: ++359 431 65167

++359 431 64271

Fax: +359 431 64114

E-Mail: msh@ms-hydraulic.com

URL: <http://www.ms-hydraulic.com>